



Q601.001

1999-2000 ARCTIC CAT 250

STAGE 1

For mildly tuned machines using the stock airbox with stock or aftermarket filter. May also be used with a good aftermarket exhaust system. K&N Filter # AC-3098.

PARTS LIST		
1	Main Jet	DJ118
1	Main Jet	DJ120
1	Main Jet	DJ122
1	Main Jet	DJ124
1	Main Jet	DJ126
1	Main Jet	DJ128
1	Main Jet	DJ130
1	Main Jet	DJ132
1	Main Jet	DJ134
1	Fuel Needle	DNO466
1	Adjusting Washer	DW0001
1	E-Clip	DE0001

STAGE ONE INSTRUCTIONS

1. Remove vacuum slide from carbs. Remove stock needles & spacers, noting order of assembly (Fig.A).
2. Install Dynojet needle on groove# 3 for applications below 5000 feet, groove #2 for above 5000 feet, using all stock spacers. Install the Dynojet washer above the E-clip.
3. Remove stock main jet and replace with Dynojet main provided. Use the DJ126 below 3000 feet, DJ 122 from 3000 to 6000 feet and DJ118 above 6000Feet. When using an aftermarket exhaust with a high flow baffle, Use the DJ130 below 3000 feet, DJ126 from 3000 to 6000 feet and the DJ122 above 6000 feet.
4. Locate the Fuel Mixture Screw (Fig.B). Using a flat blade screwdriver, turn the mixture screw clockwise until it seats, then turn out 3.5turns.

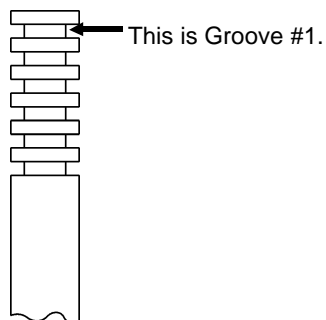

Fig. A

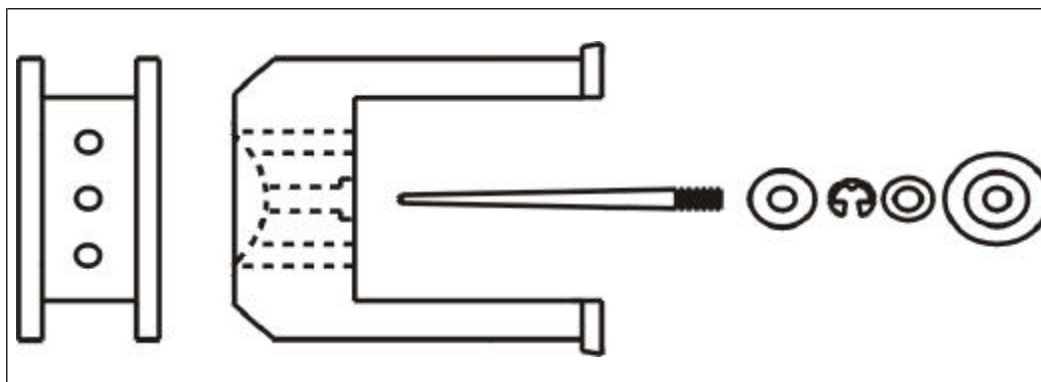

Fig. B

