



8731.001

U.S Models Only

*2000~2006 Harley Davidson
TwinCam 88*

THUNDERSLIDE STAGE 7 JET KIT

For mildly tuned machines using a high flow airbox with a good aftermarket exhaust system. May also be used with cam and piston kit.

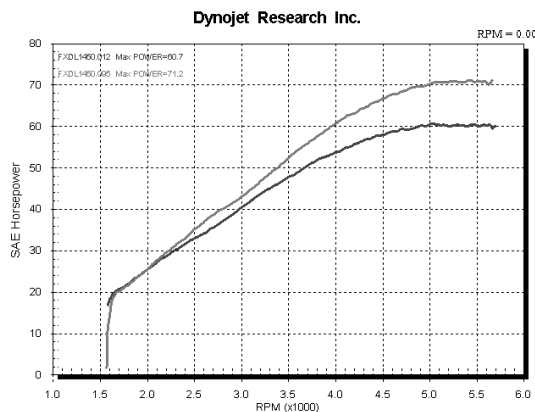

This graph shows a typical gain with a Dynojet jet kit.

WARNING

**NO SMOKING!
NO OPEN FLAME!
WHILE INSTALLING
YOUR DYNOJET KIT**

Parts List

1	Main Jet	BJ185
1	Main Jet	BJ190
1	Main Jet	BJ195
1	Main Jet	BJ200
1	Fuel Needle	DNO894
1	E-Clip	DE0001
1	Thunder Slide	DTS006
1	Diphragm Upper Retainer	DTS002
1	Diphragm Lower Retainer	DTS004
4	Carb Top Screws	37304164
1	Thunder Carb Top	HDCT001
1	Needle Spacer	THNR01
1	Emulsion Tube	DET007
1	Slide Spring	DSP088
1	Plug Drill	DD #5/32
1	Screw	DS0001
1	Diaphragm Instructions	DI8731S

Installation Instructions

DYNOJET
8731.001

1. Remove the carburetor float bowl. Remove the stock main jet and remove the emulsion tube (Fig. A), sometimes referred to as the main jet holder. Replace the stock emulsion tube with the Dynojet emulsion tube provided (DET007). When the Dynojet emulsion tube is fully seated there will still be threads visible. Install the Dynojet main jet provided. Use the BJ190 main jet with an aftermarket airbox and aftermarket exhaust. With extensive engine work ie: cams, pistons, head work, airbox and exhaust, Use the BJ195 main jet.
2. Install the e-clip on groove #4 of the Dynojet needle. Install the Thunderslide, Dynojet needle, needle spacer, white needle retainer and Dynojet slide spring (DSP088) into the carb body (Fig. A).
3. Locate the fuel mixture plug (Fig. B), if you see a screw head at Fig. B proceed to the adjusting procedure. With the 5/32 drill provided, carefully drill through the plug. **NOTE:** The mixture screw is directly underneath this plug, be ready to pull back on the drill the instant you break through. Use screw provided to secure and remove this plug. Carefully turn mixture screw in until lightly seated, then back out 3.5 turns.

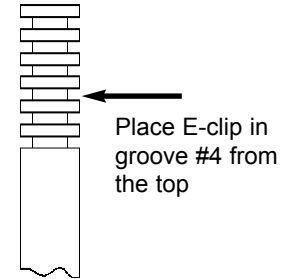

Fig. A

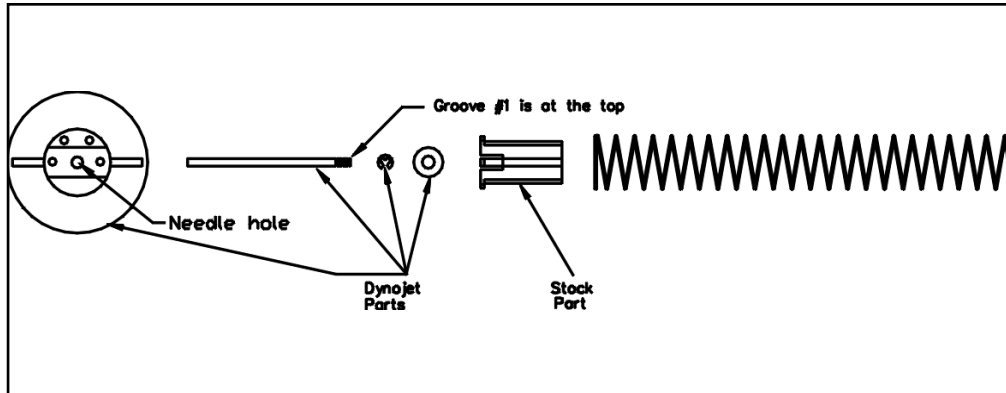
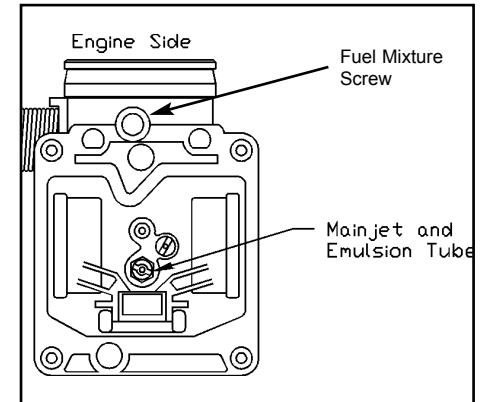

Fig. B



THUNDERSLIDE INSTALLATION INSTRUCTIONS

DYNOJET
DI8731S.001

1. Remove the carb top, slide spring, needle retainer, and needle.
2. Carefully remove the original rubber diaphragm from the metal slide by gently pulling at the inner edge of the diaphragm in a circular motion until diaphragm is out of the stock slide retaining groove. The stock rubber diaphragm will be installed on the Thunderslide.
3. To assemble the stock diaphragm on the Thunderslide, first install the larger slide retainer (DTS004) with the radial grooves facing up on to the slide (Fig. A). You will notice that the slide has a collar on the top which you will have to push the larger retainer past.
4. Lay the diaphragm on the lower retainer in the same direction it was on the stock slide.
5. Press the small slide retainer (DTS002) with the grooves facing down, on top of the diaphragm (Fig. A). You should hear a “snap” as it goes together. Make sure it is flat and secure on top of the slide and that the diaphragm is centered.
6. Install the Thunder Carb Top in place of the stock carb top using the screws provided.

Fig. A

