



8101.002

U.S. models only

*1988-89 Harley Davidson 883-1200
w/40 mm Keihin CV Carb*

Stage 1

For mildly tuned machines using the stock or high flow airbox and or filter. May also be used with a good aftermarket exhaust system.

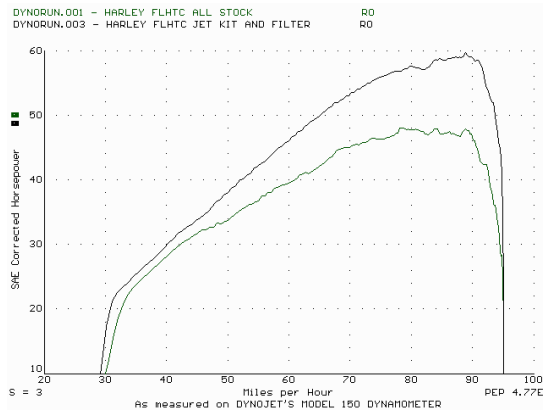

This graph shows a typical gain with a Dynojet jet kit.

WARNING

**NO SMOKING!
NO OPEN FLAME!
WHILE INSTALLING
YOUR DYNOJET KIT**

Parts List

1	Main Jet	DJ160
1	Main Jet	DJ170
1	Main Jet	DJ180
1	Main Jet	DJ190
1	Slide Drill	DD #29
1	Fuel Needle	DNO850
3	Adjusting Washers	DW0001
1	E-Clip	DE0001
1	Slide Spring	DSP009
1	Emulsion Tube	DET001
1	Plug Drill	DD #5/32
1	Screw	DS0001

STAGE ONE INSTRUCTIONS

DYNOJET
8101.002

Note: Your carburetor should have an accelerator pump like the one shown in Fig. C. If it does not contact Dynojet.

1. Remove the carb top, slide spring, needle retainer and diaphragm noting the order of assembly (Fig. A). Locate the slide lift hole in Fig. A. Using the drill bit provided (DD #29) enlarge your slide lift hole. **Do not drill the needle hole.**
2. Install the e-clip on groove #3 if the bike is all stock. If you are using an exhaust, cam or aftermarket airbox then set the needle on groove #4. Install Dynojet washers above the e-clip. Install the Dynojet slide spring (DSP009) in place of the stock spring. Make sure the spring is aligned properly. You may use the stock spring for slower throttle response.
3. Remove the carburetor float bowl. Remove the stock main jet and remove the emulsion tube (Fig. B), sometimes referred to as the main jet holder. Replace the stock emulsion tube with the Dynojet emulsion tube provided (DET001). When the Dynojet emulsion tube is fully seated there will still be threads visible. Install the Dynojet main jet provided. Use the DJ170 main jet with a completely stock bike. Use the DJ180 main jet with an aftermarket airbox, exhaust, or cam.
4. Locate the fuel mixture plug (Fig. C), if you see a screw head at Fig. C proceed to the adjusting procedure. With the DD #5/32 drill bit provided, carefully drill through the plug. **Note:** The mixture screw is directly underneath this plug, be ready to pull back on the drill the instant you break through. Use screw provided to secure and remove this plug. Carefully turn mixture screw in until lightly seated, then back out 3 turns.

Note:

In order for this kit to work properly, your pilot circuit must be completely stock. Also make sure that the pilot jet has not been drilled larger.

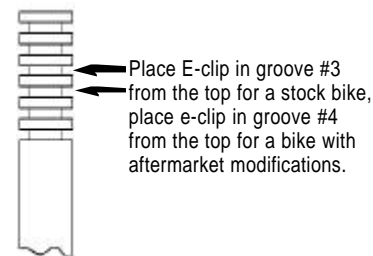

Fig. A

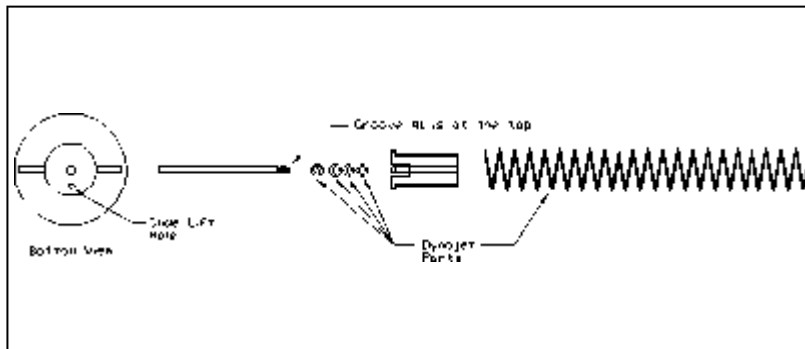

Fig. B

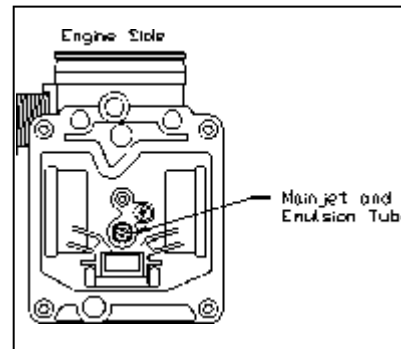

Fig. C

