



PART#: DSB (1, 2, 3, 4, 6, 8, 10, 11, 12, 13, 15, 16, 17, 18, 19, 20, 21)
(Installation Instructions)

1. Make sure ignition key is turned to the off position and engine is cool.
2. Place motorcycle on lift, rear stand, or side stand.
3. Locate the final destination of the new block off plates.
4. Carefully remove any fairings if needed.
5. Carefully remove fuel tank and air box.
6. Carefully remove any parts obstructing the OEM plates and then remove them.
7. Using blue Loctite, install the new block off plates using the OEM hardware,
8. and the OEM sealing "O rings" if present.
9. Locate OEM air hose leading to the airbox from the OEM plates removed.
10. Using supplied cap, remove hose and plug airbox.
11. Carefully replace airbox, fuel tank, fairings, and any other pieces removed during installation.
*To ensure the FI light will not come on the second air pump must be plugged in.

NOTE: *Unplugging the pump from the wire harness will make the FI light come on.

*On DSBLOCK 1 and 6, screws and reeds have to be removed

DRIVEN REQUIRES THIS PRODUCT TO BE INSTALLED BY A CERTIFIED TECHNICIAN

NOT INTENDED FOR STREET/HIGHWAY USE! FOR OFF ROAD/RACE USE ONLY!

- | | |
|------------|------------|
| DSBLOCK-1 | DSBLOCK-11 |
| DSBLOCK-2 | DSBLOCK-13 |
| DSBLOCK-3 | DSBLOCK-16 |
| DSBLOCK-4 | DSBLOCK-17 |
| DSBLOCK-6 | DSBLOCK-18 |
| DSBLOCK-8 | DSBLOCK-19 |
| DSBLOCK-10 | DSBLOCK-20 |
| | DSBLOCK-21 |

DSBLOCK-15

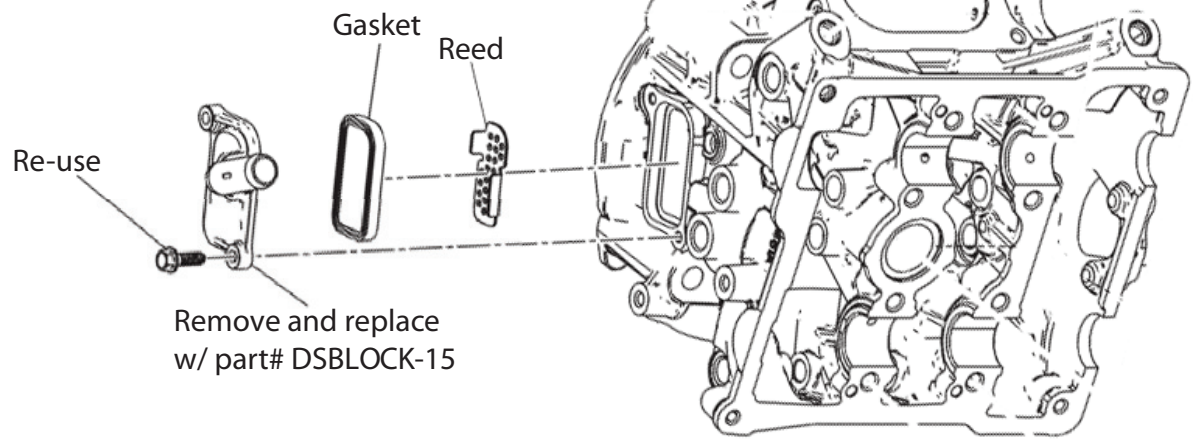

YOU MUST REPLACE REED AND GASKET! (DO NOT REMOVE)

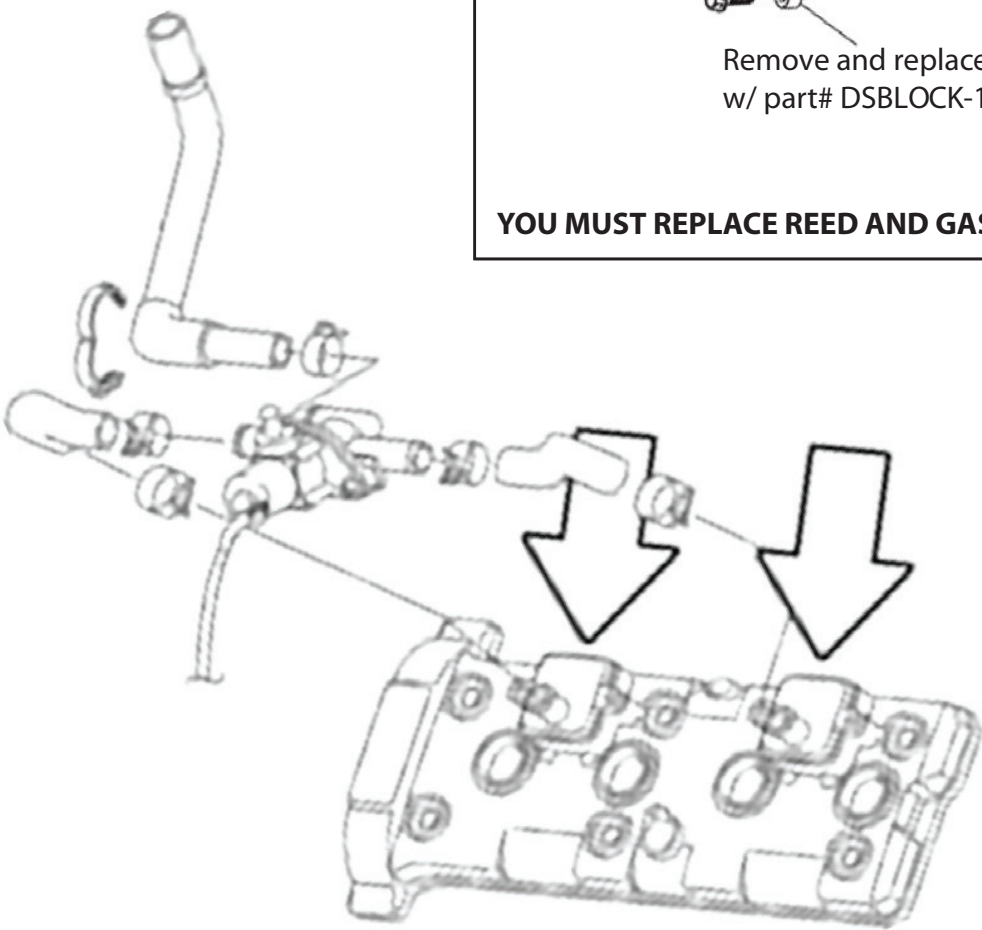

DSBLOCK-12

