

# Instruction Manual

Instruction Rev02



## SoundBomb Compact Dual-Tone Horn TT-SB.10000.B

### Thank you for choosing DENALI

We know you would rather be enjoying your vehicle than wrenching on it, so we go the extra mile to make sure our instructions are clear and as easy to understand as possible.

### Please Read Before Installing

DENALI products should always be installed by a qualified technician. If you are unsure of your ability to properly install a product, please have the product installed by your local motorcycle dealer. DENALI takes no responsibility for damages caused by improper installation. **Caution:** When installing electronics it is extremely important to pay close attention to how wires are routed, especially when mounting products to the front fender, front forks, or fairing of a motorcycle. Always be sure to turn the handle-bars fully left, fully right, and fully compress the suspension to ensure the wires will not bind and have enough slack for your motorcycle to operate properly.

### Installation Tips

We strongly recommend using medium strength liquid thread locker on all screws, nuts, and bolts. It is also important to ensure that all hardware is tightened to the proper torque specifications as listed in your owner's manual. For included accessory hardware please refer to the default torque specifications provided below. Inspect all hardware after the first 30 miles to ensure proper torque specifications are maintained.

Bolt Size	in-lbs	ft-lbs	Nm
M3	10.0 in-lbs	-	1.0 Nm
M4	23.0 in-lbs	-	2.5 Nm
M5	44.5 in-lbs	3.5 ft-lbs	5.0 Nm
M6	78.0 in-lbs	6.5 ft-lbs	9.0 Nm
M8	-	13.5 ft-lbs	18.0 Nm
M10	-	30.0 ft-lbs	41.0 Nm
M12	-	52.0 ft-lbs	71.0 Nm

### Hardware Sizing Guide

Not sure what size bolt you have? Use this ruler to measure screws, bolts, spacers, etc. Remember, the length of a screw or bolt is measured from the start of the "mounting surface" to the end of the screw, so only include the screw head when measuring countersunk screws.

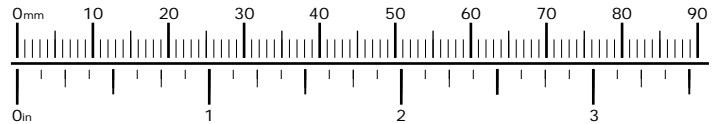

## What's In The Box?



### Kit Contents

- (a) SoundBomb Compact Horn.....Qty 1
- (b) 12 Volt 30 Amp Relay.....Qty 1
- (c) M8x16 DIN 933.....Qty 1
- (d) M8 Nut DIN 985.....Qty 1

# 1. Mounting The Horn

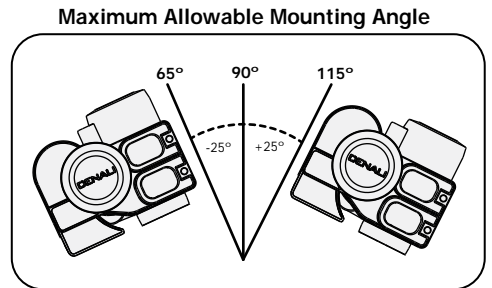
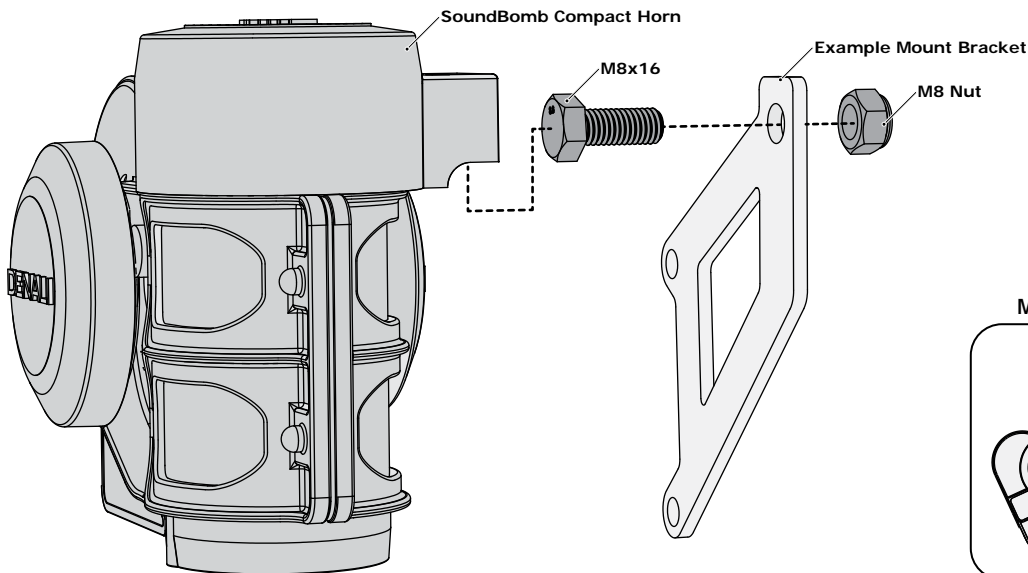

## 1.1 - Horn Mounting Overview

Find a suitable mounting location on the vehicle that is protected from road debris and spray from your tires. Universal and Vehicle-Specific Mounting Brackets are available for purchase separately.

**Note:** The horn should be mounted so that the cylinder is vertical with the horn facing down. There should be no more than a 25 degree variance from the vertical position.

## 1.2 - Mounting The Horn

**Step One:** Use the M8x16 Bolt (c) and M8 Nut (d) to attach the horn to the mounting location.

# 2. Wiring The Horn

**Note:** This drawing is not to scale. Components enlarged for illustration purposes only.

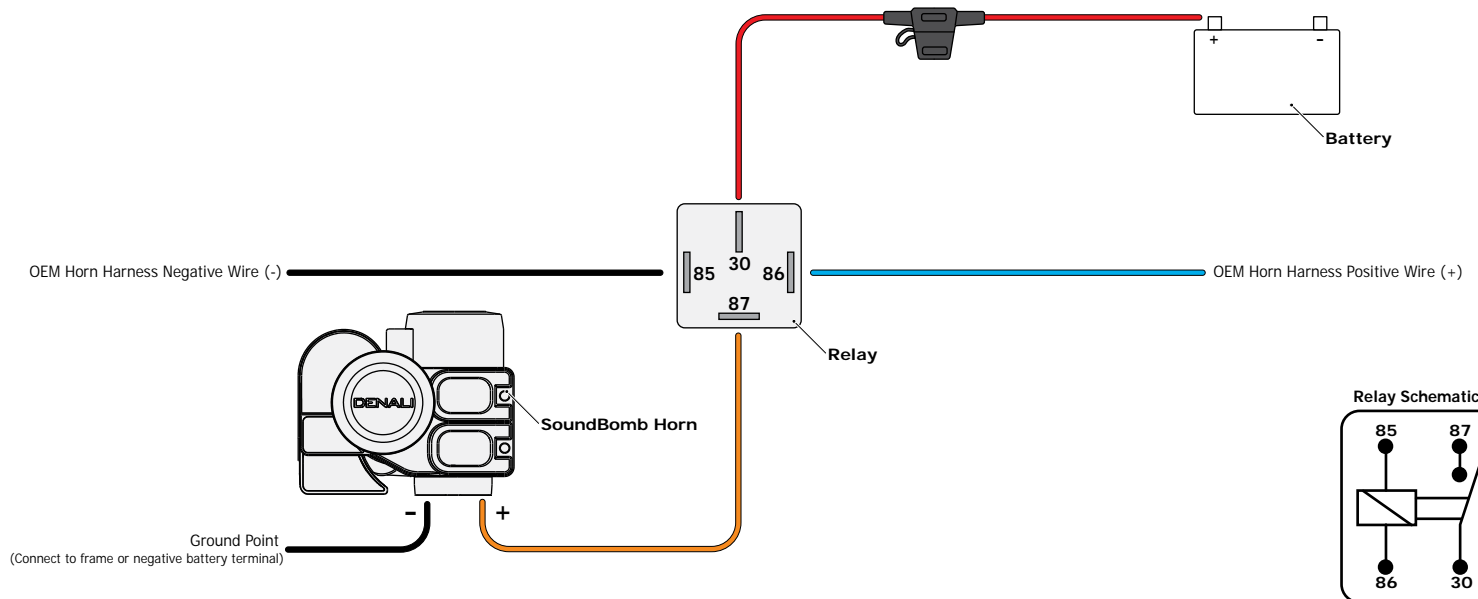

## 2.1 - Wiring

We recommend using the DENALI Plug-N-Play SoundBomb Horn Wiring Kit to make the install a breeze. (Available for separate purchase, P/N: DNL.ELC.10000) However the horn can easily be wired using the included 12 Volt 30 Amp Relay (b) and some basic electrical supplies.

**Step One:** Connect terminal 85 to the OEM horn harness negative (-) wire.

**Step Two:** Connect terminal 30 to the OEM horn harness positive (+) wire. Install a fuse holder in-line.

**Step Three:** Connect terminal 87 to the positive terminal of the SoundBomb Horn.

**Step Four:** Connect a ground wire from the negative (-) terminal of the SoundBomb Horn to a ground point on the vehicle or the negative terminal of the battery. Looking at the front of the horn the negative terminal will be on the left.

**Step Five:** Connect Terminal 86 to the OEM horn harness positive (+) wire.

**Step Six:** Install a 30 Amp fuse into the fuse holder.

**Note:** Place the Relay in an easily accessible location for convenient service in the event of a faulty relay.