

DENALI™

TT-M5
TT-M7

DOT LED HEADLIGHT MODULE
SEALED BEAM DIRECT REPLACEMENT
5.75" ROUND
7.00" ROUND

Thank you for choosing DENALI

We know you would rather be riding your bike than wrenching on it, so we go the extra mile to make sure our instructions are clear and as easy to understand as possible.

Please Read Before Installing

DENALI products should always be installed by a qualified motorcycle technician. If you are unsure of your ability to properly install a product, please have the product installed by your local motorcycle dealer. DENALI takes no responsibility for damages caused by improper installation. **Caution:** When installing electronics is it extremely important to pay close attention to how wires are routed, especially when mounting products to the front fender, front forks, or fairing of your motorcycle. Always be sure to turn the handlebars fully left, fully right, and fully compress the suspension to ensure the wires will not bind and have enough slack for your motorcycle to operate properly.

Installation Tips

We strongly recommend using medium strength liquid thread locker on all screws, nuts, and bolts. It is also important to ensure that all hardware is tightened to the proper torque specifications as listed in your owner's manual. For included accessory hardware please refer to the default torque specifications provided below. Inspect all hardware after the first 30 miles to ensure proper torque specifications are maintained.

Bolt Size	in-lbs	ft-lbs	Nm
M3	10.0 in-lbs	-	1.0 Nm
M4	23.0 in-lbs	-	2.5 Nm
M5	44.5 in-lbs	3.5 ft-lbs	5.0 Nm
M6	78.0 in-lbs	6.5 ft-lbs	9.0 Nm
M8	-	13.5 ft-lbs	18.0 Nm
M10	-	30.0 ft-lbs	41.0 Nm
M12	-	52.0 ft-lbs	71.0 Nm

Hardware Sizing Guide

Not sure what size bolt you have? Use this metric ruler to measure screws, bolts, spacers, etc. Remember, the length of a screw or bolt is measured from the start of the "mounting surface" to the end of the screw, so only include the screw head when measuring countersunk screws.

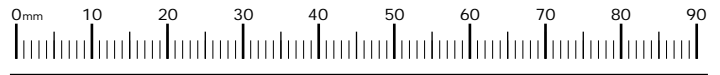

FIGURE 1



Illustration not to scale

Kit Contents

- (a) DOT LED Module.....Qty 1
- (b) Posi-Tap.....Qty 1
- (c) Posi-Lock.....Qty 1
- (d) Black Wire.....3ft

Tools Required

- Phillips-Head Screwdriver

FIGURE 2

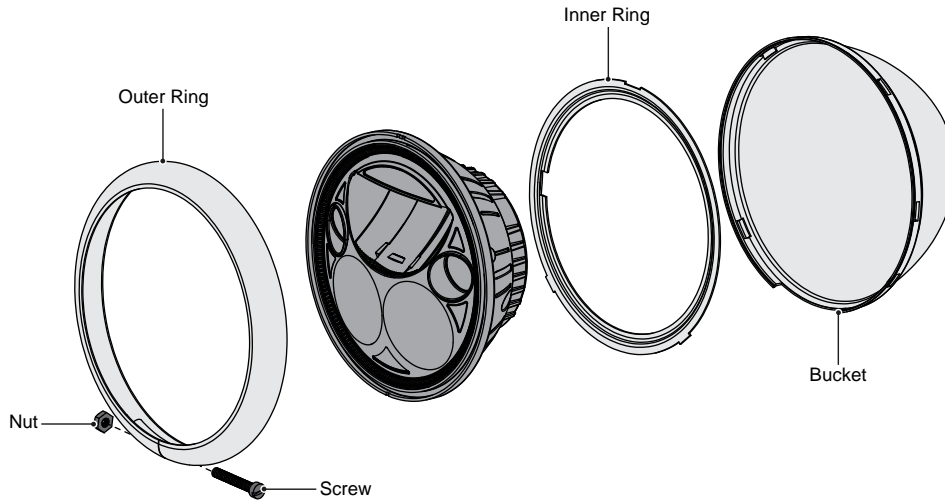

Please Read Before Installing

There are several different variations of headlight buckets commonly found on motorcycles. The three most common styles are illustrated, however other variations not shown will also accept the LED Module. Keep in mind that your headlight may vary slightly from the illustrations, they are meant only to be a guide.

NOTE: Some headlight bucket styles have the mounting tabs molded directly to the sealed beam, rather than being clamped or

bolted into the bucket with other components as in the examples above. If your headlight bucket is assembled in this fashion the LED Module will **NOT** be compatible.

Figure Two

This style headlight bucket utilizes an outer ring to clamp the sealed beam and an inner ring into place in the bucket.

Step One: Simply loosen and remove the nut and bolt on the bottom side of the outer ring.

Step Two: Next remove the outer ring from the headlight bucket, use caution as the sealed beam is no longer held in place and may fall out.

Step Three: Unplug the sealed beam and plug in the LED module (See Figure 5 for halo wiring information).

Step Four: Finally re-install the outer ring to clamp the LED Module and inner ring into place.

FIGURE 3

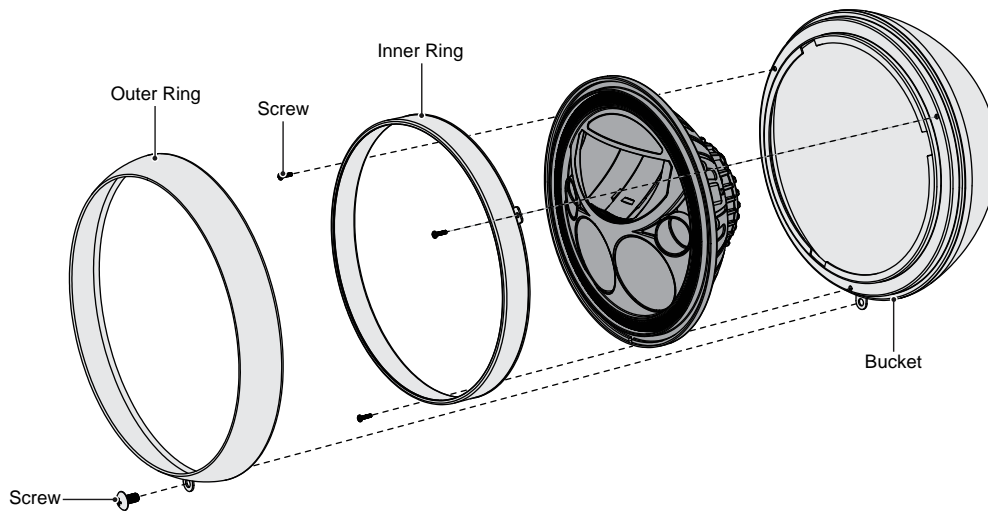

Figure Three

This style headlight bucket uses an inner ring to clamp the sealed beam to the bucket, then an decorative outer ring to hide the hardware.

Step One: Start by removing the outer decorative ring, it is typically held in place by one screw on the under side of the bucket.

Step Two: Once removed you will notice several screws (typically 3) holding the inner ring to the bucket. Remove these screws

and the inner ring, use caution as the sealed beam is no longer held in place and may fall out.

Step Three: Unplug the sealed beam and plug in the LED module (See Figure 5 for halo wiring information).

Step Four: Re-install the inner ring to clamp the LED Module into place, finally re-install the outer decorative ring.

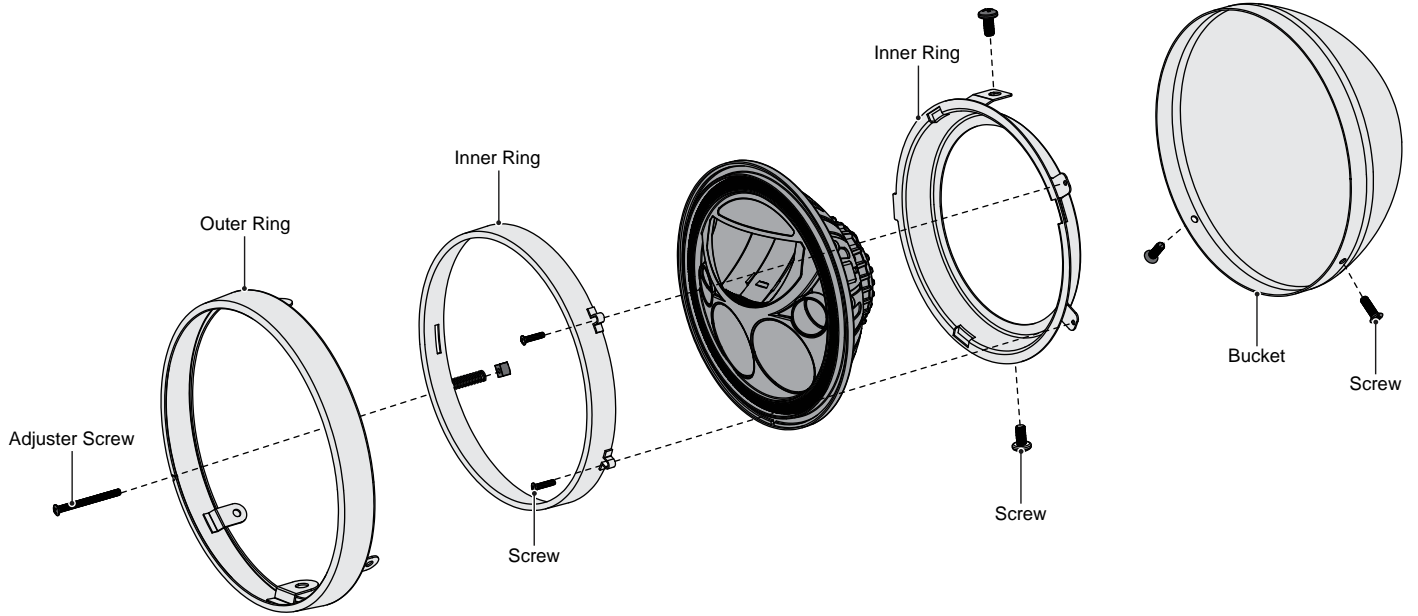
FIGURE 4**Figure Four**

This is the most complex style headlight bucket, it utilizes a series of rings and adjusters to mount the sealed beam in the bucket.

Step One: Start by removing the two screws visible on the bottom side of the bucket, once these have been removed the sealed beamed and all of its bracketry will come out of the headlight bucket. The sealed beam will need to be unplugged at this time.

Step Two: Next you will need to completely back out all of the adjuster screws, be sure to take note of there original position or mark them, this will be helpful when re-assembling the unit.

Step Three: Next there will be screws holding the outer most ring to the two inner clamping rings, typically there is one screw on top and another on the bottom.

Step Four: Once the outer most ring is

removed you will see more screws clamping the two inner most rings together, ultimately sandwiching the sealed beam between. Remove these screws, use caution as the sealed beam will no longer be clamped in place and may fall out.

Step Five: Replace the sealed beam with the LED Module then clamp it between the two inner rings using the original hardware.

Step Six: Next re-install the adjuster screws

and the outer most ring. When re-installing the adjuster screws, put them back to there original position, further adjustment will likely be needed but this will give you a good starting point.

Step Six: The assembly can now be reinstalled to the bucket. Be sure to plug in the LED module (See Figure 5 for halo wiring information) before screwing the assembly into the bucket.

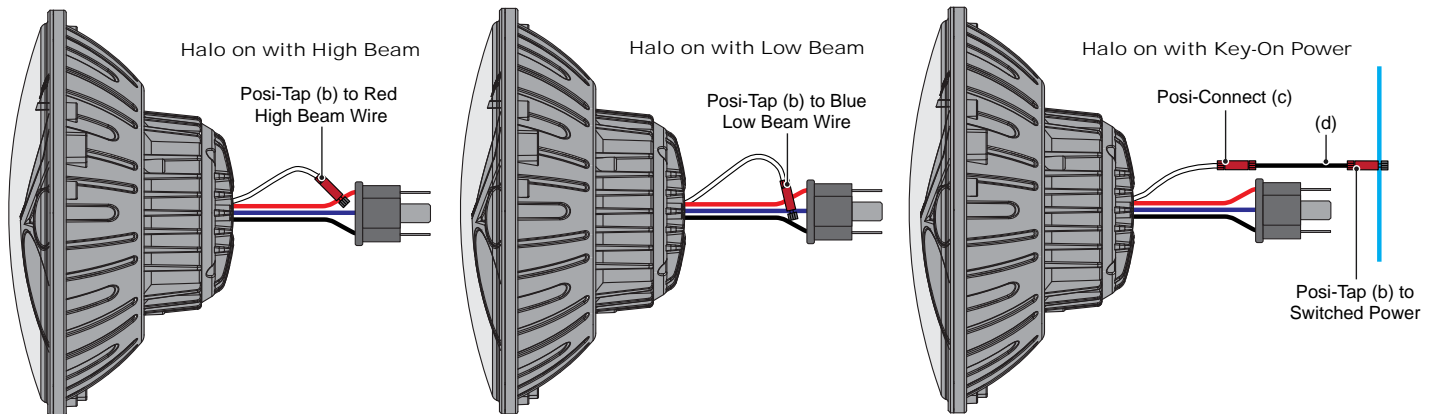
FIGURE 5

Halo Wiring

There are three different options to wire the Halo of you LED Module. Refer to illustrations in Figure 5.

On with High Beam: Use the Posi-Tap (b) to tap the white Halo wire into the red high beam wire.

On with Low Beam: Use the Posi-Tap (b) to tap the white Halo wire into the blue low beam wire.

On with Key-On Power: Use Posi-Tap (b) to tap the white halo wire into a wire on your bikes harness that only gets power once the ignition has been turned on. For example, your motorcycles running light wire or dash light wire are a switched 12 volt power source.

If extra length is required to access switched power use the Posi-Connect (c) and Wire (d) to extend the halo wire to the source.