

DENALI™

TT-M4

LED PASSING LAMP MODULE
SEALED BEAM DIRECT REPLACEMENT
4.5" ROUND

Thank you for choosing DENALI

We know you would rather be riding your bike than wrenching on it, so we go the extra mile to make sure our instructions are clear and as easy to understand as possible.

Please Read Before Installing

DENALI products should always be installed by a qualified motorcycle technician. If you are unsure of your ability to properly install a product, please have the product installed by your local motorcycle dealer. DENALI takes no responsibility for damages caused by improper installation. **Caution:** When installing electronics is it extremely important to pay close attention to how wires are routed, especially when mounting products to the front fender, front forks, or fairing of your motorcycle. Always be sure to turn the handlebars fully left, fully right, and fully compress the suspension to ensure the wires will not bind and have enough slack for your motorcycle to operate properly.

Installation Tips

We strongly recommend using medium strength liquid thread locker on all screws, nuts, and bolts. It is also important to ensure that all hardware is tightened to the proper torque specifications as listed in your owner's manual. For included accessory hardware please refer to the default torque specifications provided below. Inspect all hardware after the first 30 miles to ensure proper torque specifications are maintained.

Bolt Size	in-lbs	ft-lbs	Nm
M3	10.0 in-lbs	-	1.0 Nm
M4	23.0 in-lbs	-	2.5 Nm
M5	44.5 in-lbs	3.5 ft-lbs	5.0 Nm
M6	78.0 in-lbs	6.5 ft-lbs	9.0 Nm
M8	-	13.5 ft-lbs	18.0 Nm
M10	-	30.0 ft-lbs	41.0 Nm
M12	-	52.0 ft-lbs	71.0 Nm

Hardware Sizing Guide

Not sure what size bolt you have? Use this ruler to measure screws, bolts, spacers, etc. Remember, the length of a screw or bolt is measured from the start of the "mounting surface" to the end of the screw, so only include the screw head when measuring countersunk screws.

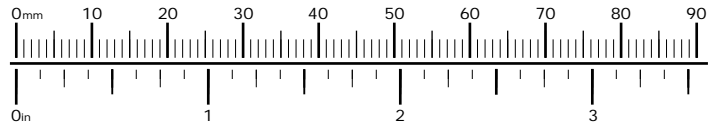

Kit Contents

- (a) LED Module.....Qty 2
- (b) Posi-Lock.....Qty 2
- (c) Posi-Tap.....Qty 2
- (d) Male Spade Connector.....Qty 2
- (e) 3 ft Black Wire.....Qty 2

Tools Required

- Phillips-Head Screwdriver

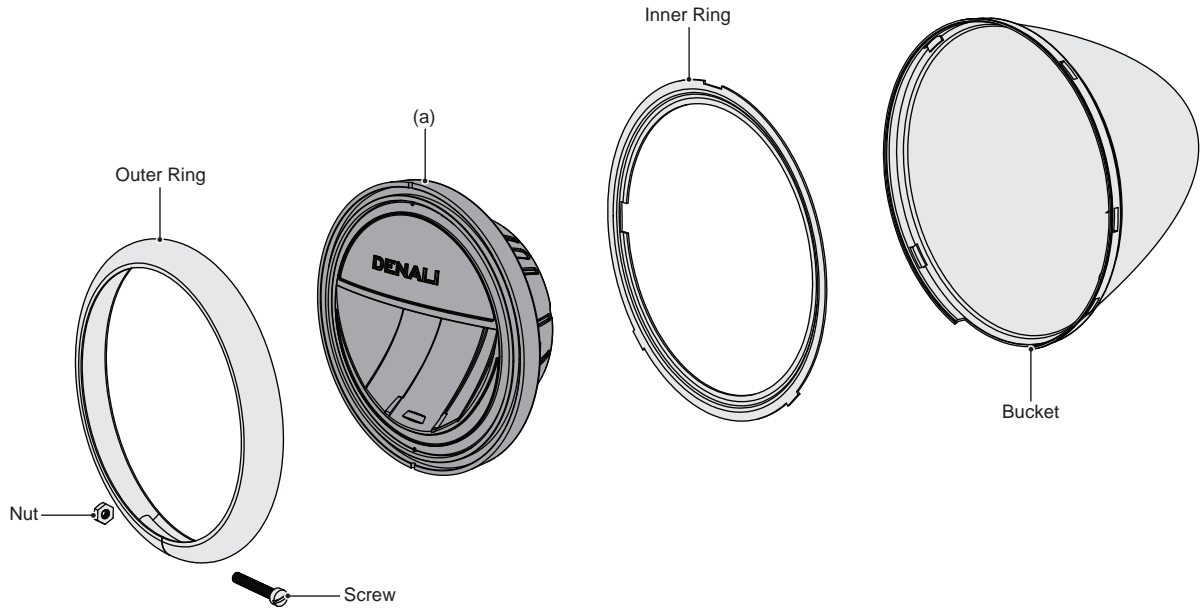
FIGURE 2

Installing The LED Module

Step One: Simply loosen and remove the nut and bolt from the bottom of the passing lamp housing outer ring.

Step Two: Next remove the outer ring from the passing lamp housing, use caution as the sealed beam is no longer held in place and may fall out.

Step Three: Unplug the factory sealed beam and plug in the DENALI LED module. (See Figure 3 for optional halo wiring information).

Note: 2004 and earlier Harley Davidson models use spade connectors. Replace the 2-pin H9/H11 connector with the included spade connectors (d) for plug-n-play installation. The Black with Grey striped wire is Harley Davidson positive 12v DC.

Step Four: Finally re-install the outer ring to clamp the LED Module and inner ring into place.

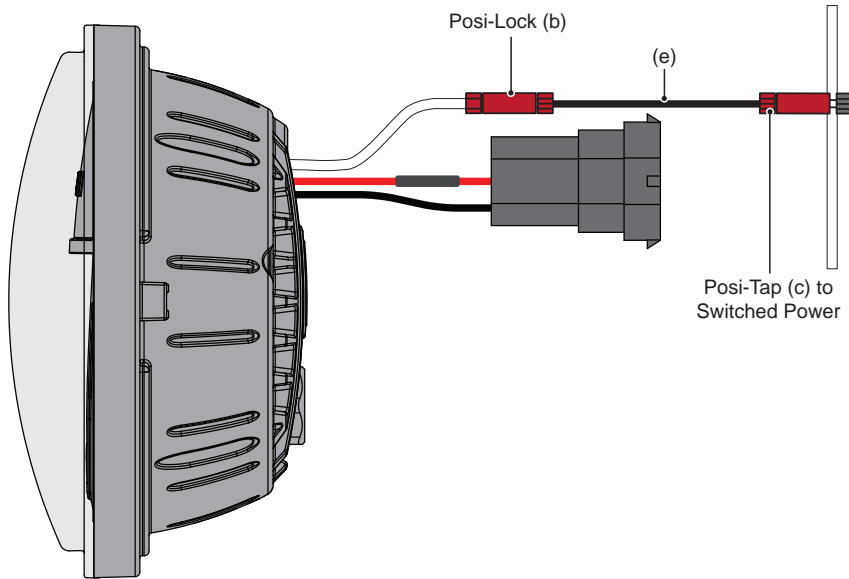
FIGURE 3

Independent Halo Wiring Option

The DENALI M4 LED Passing Lamp Module comes out of the box with the Halo pre-wired to be ON when the lamp is ON. If you prefer to have the Halo turn ON with the motorcycles "Key-On Power", follow the instructions below.

Step One: Use a pair of electrical snips to cut and remove the black sheathing from around the three wires coming from the rear of the module.

Step Two: Cut and separate the white Halo wire from the red positive wire.

Step Three: Use electrical tape to cover the exposed lead leftover from the white wire.

Step Four: Use the Posi-Lock (b) and Wire (e) to extend the white halo wire, then use Posi-Tap (c) to tap the halo wire into a wire on your bikes harness that only gets power once the ignition has been turned on. For example, your motorcycles running light wire or dash light wire are a switched 12 volt power source.