

DENALI™

LAH.05.10400

HEADLIGHT MODULE ADAPTER

- SUZUKI VOLUSIA 2001-2004
- SUZUKI BOULEVARD C50 2005 - 2009
- SUZUKI BOULEVARD C50 2011 - PRESENT
- SUZUKI BOULEVARD C90 2005 - 2009
- SUZUKI BOULEVARD C90 2013 - PRESENT

Thank you for choosing DENALI

We know you would rather be riding your bike than wrenching on it, so we go the extra mile to make sure our instructions are clear and as easy to understand as possible.

Please Read Before Installing

DENALI products should always be installed by a qualified motorcycle technician. If you are unsure of your ability to properly install a product, please have the product installed by your local motorcycle dealer. DENALI takes no responsibility for damages caused by improper installation. **Caution:** When installing electronics it is extremely important to pay close attention to how wires are routed, especially when mounting products to the front fender, front forks, or fairing of your motorcycle. Always be sure to turn the handlebars fully left, fully right, and fully compress the suspension to ensure the wires will not bind and have enough slack for your motorcycle to operate properly.

Installation Tips

We strongly recommend using medium strength liquid thread locker on all screws, nuts, and bolts. It is also important to ensure that all hardware is tightened to the proper torque specifications as listed in your owner's manual. For included accessory hardware please refer to the default torque specifications provided below. Inspect all hardware after the first 30 miles to ensure proper torque specifications are maintained.

Bolt Size	in-lbs	ft-lbs	Nm
M3	10.0 in-lbs	-	1.0 Nm
M4	23.0 in-lbs	-	2.5 Nm
M5	44.5 in-lbs	3.5 ft-lbs	5.0 Nm
M6	78.0 in-lbs	6.5 ft-lbs	9.0 Nm
M8	-	13.5 ft-lbs	18.0 Nm
M10	-	30.0 ft-lbs	41.0 Nm
M12	-	52.0 ft-lbs	71.0 Nm

Hardware Sizing Guide

Not sure what size bolt you have? Use this metric ruler to measure screws, bolts, spacers, etc. Remember, the length of a screw or bolt is measured from the start of the "mounting surface" to the end of the screw, so only include the screw head when measuring countersunk screws.



FIGURE 1

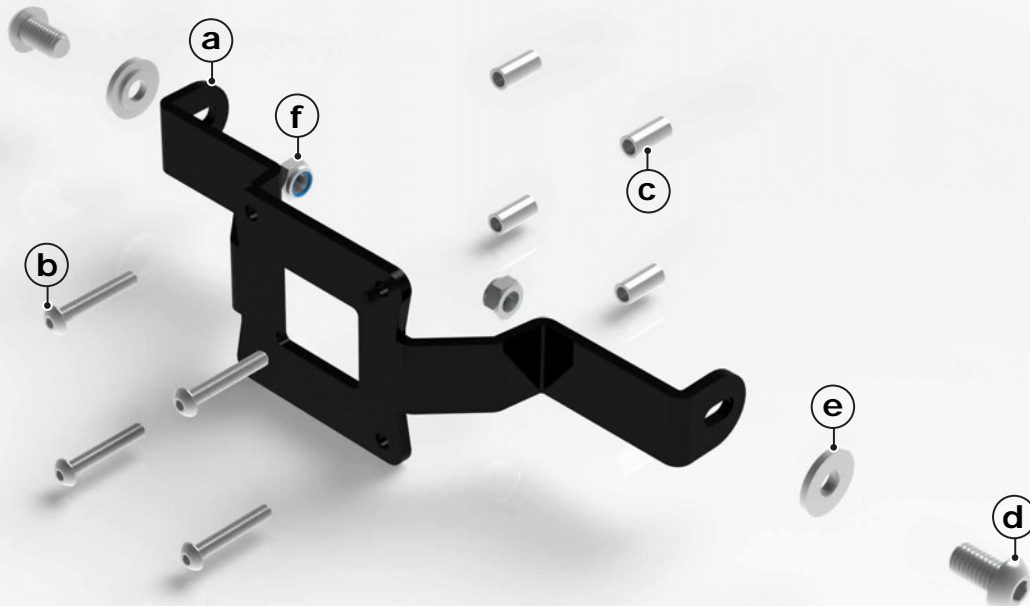

Illustration not to scale

Kit Contents

- (a) Bracket (LAH.05.004).....Qty 1
- (b) M4x25 ISO 7380.....Qty 4
- (c) OD:6.4, ID:4.4, L:13.5.....Qty 4
- (d) M6x14 ISO 7380.....Qty 2
- (e) Bushing, 12mm to 6mm.....Qty 2
- (f) M6 Nut DIN 985.....Qty 2

Tools Required

- 4mm Allen Key
- 2.5mm Allen Key
- 10mm Wrench
- Phillips Head Screwdriver

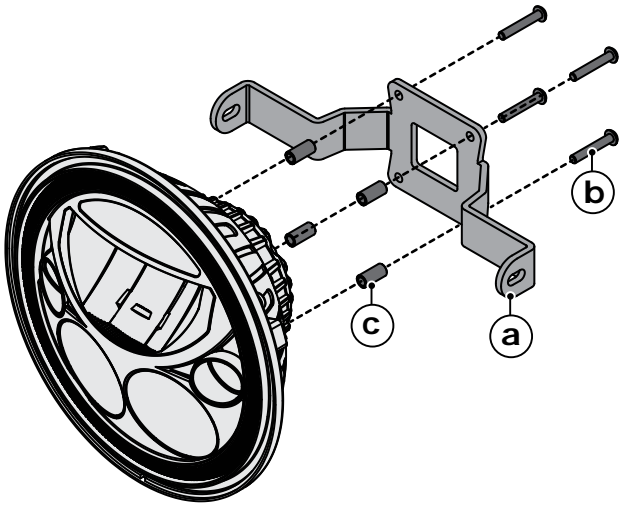
FIGURE 2

Mounting The Bracket

Step One: Begin by removing the four socket head bolts from the rear of the light.

Step Two: Use the M4x25 bolts (b) and spacers (c) to bolt bracket (a) to the rear of the LED headlight module.

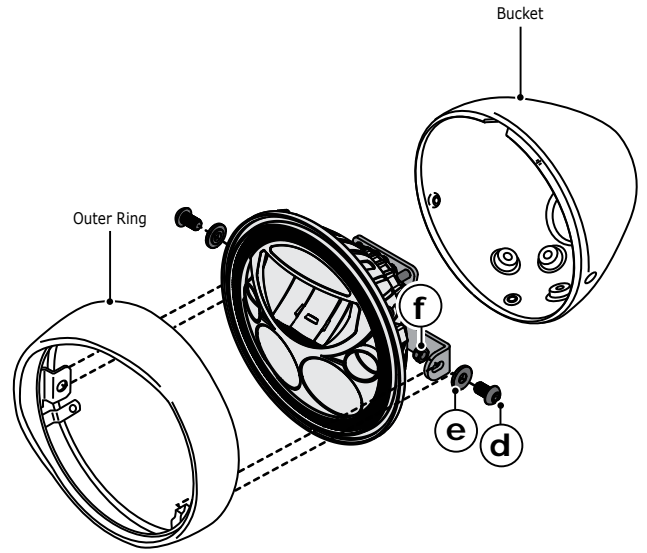
FIGURE 3

Installing The Module

Step Three: Disassemble the head light bucket and remove the OEM sealed beam unit.

Step Four: Use the bushing (e) to center the M6x14 bolt (d) in the hole of larger tab of the outer ring.

Step Five: Next use the M6 nuts (f) to secure the headlight module and bracket (a) to the outer ring.

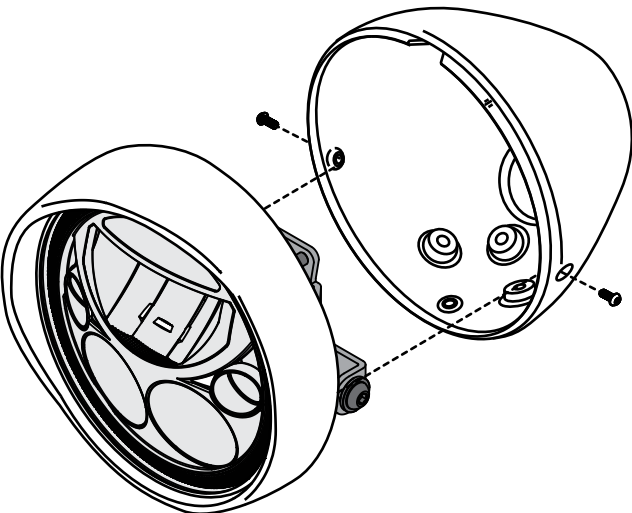
FIGURE 4

Installing The Module

Step Six: Re-use the OEM screws to attach the outer ring to the headlight bucket.

Note: Please refer to the instructions manual of the M5 LED DOT Headlight Module for wiring instructions.