

DENALI™

LAH.00.10300.B
LAH.00.10300.C

ENGINE GUARD / CRASHBAR
LIGHT MOUNT
(2 1 MM-29MM/ $\frac{2}{8}$ "-1 $\frac{1}{8}$ ")

Thank you for choosing DENALI

We know you would rather be riding your bike than wrenching on it, so we go the extra mile to make sure our instructions are clear and as easy to understand as possible.

Please Read Before Installing

DENALI products should always be installed by a qualified motorcycle technician. If you are unsure of your ability to properly install a product, please have the product installed by your local motorcycle dealer. DENALI takes no responsibility for damages caused by improper installation. **Caution:** When installing electronics is it extremely important to pay close attention to how wires are routed, especially when mounting products to the front fender, front forks, or fairing of your motorcycle. Always be sure to turn the handlebars fully left, fully right, and fully compress the suspension to ensure the wires will not bind and have enough slack for your motorcycle to operate properly.

Installation Tips

We strongly recommend using medium strength liquid thread locker on all screws, nuts, and bolts. It is also important to ensure that all hardware is tightened to the proper torque specifications as listed in your owner's manual. For included accessory hardware please refer to the default torque specifications provided below. Inspect all hardware after the first 30 miles to ensure proper torque specifications are maintained.

Bolt Size	in-lbs	ft-lbs	Nm
M3	10.0 in-lbs	-	1.0 Nm
M4	23.0 in-lbs	-	2.5 Nm
M5	44.5 in-lbs	3.5 ft-lbs	5.0 Nm
M6	78.0 in-lbs	6.5 ft-lbs	9.0 Nm
M8	-	13.5 ft-lbs	18.0 Nm
M10	-	30.0 ft-lbs	41.0 Nm
M12	-	52.0 ft-lbs	71.0 Nm

Hardware Sizing Guide

Not sure what size bolt you have? Use this metric ruler to measure screws, bolts, spacers, etc. Remember, the length of a screw or bolt is measured from the start of the "mounting surface" to the end of the screw, so only include the screw head when measuring countersunk screws.

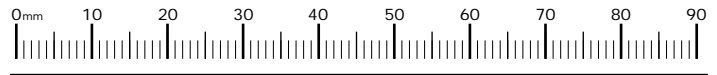

FIGURE 1

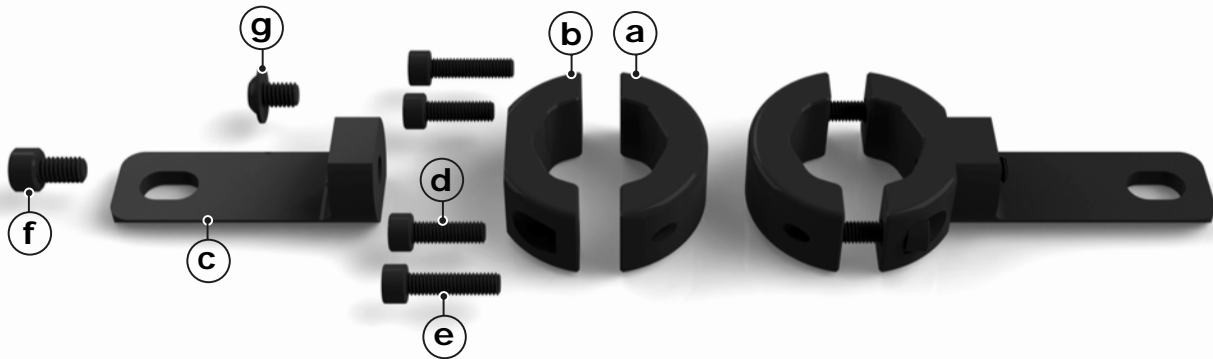

Illustration not to scale

Kit Contents

- | | |
|---------------------------------------|-----------------------------|
| (a) Clamp 1 (LAH.00.005).....Qty 2 | (f) M6x10 DIN 912.....Qty 2 |
| (b) Clamp 2 (LAH.00.006).....Qty 2 | (g) M6x8 ISO 7380.....Qty 2 |
| (c) Light Shelf (LAH.00.011)....Qty 2 | |
| (d) M5x16 DIN 912.....Qty 4 | |
| (e) M5x20 DIN 912.....Qty 4 | |

Tools Required

- 5mm Allen Key
- 4mm Allen Key
- 13mm Wrench

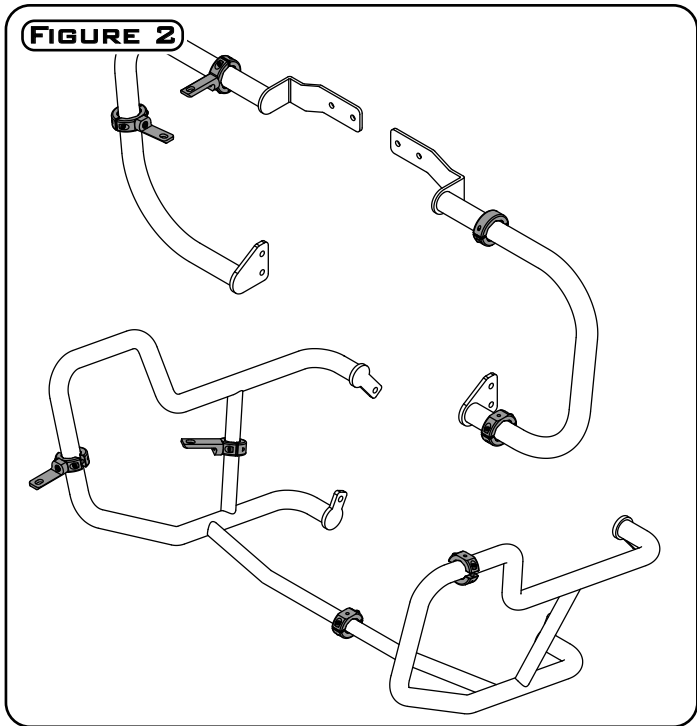

Choosing Your Mounting Location

Step One: Identify the location on the bars which you plan to mount the clamps. Notice that the lights can either rest on, or hang from, the light shelf.

Caution: It's extremely important to confirm that your clamp location will not place the clamps or the lights in the path of your suspension travel or steering as you turn the handlebars fully left and fully right.

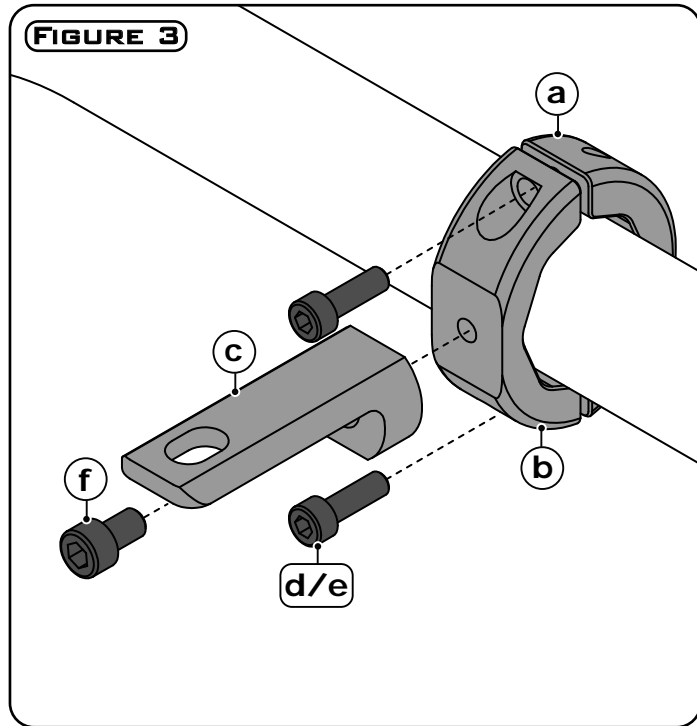

Mounting The Clamps

Step Two: Use the M5 socket head cap screws to fasten the clamps to the bar.

Note: You will need to use the longer M5x20 screws (e) when mounting to bars 26mm to 29mm in diameter.

Step Three: Alternate tightening the bolts on each side of the clamp till 3.5 ft-lbs has been achieved on each side.

Step Four: Use the M6x10 socket head cap

screw (f) to fasten the light shelf (c) to the clamp in the desired orientation. Notice that the lights can either rest on, or hang from, the light shelf.

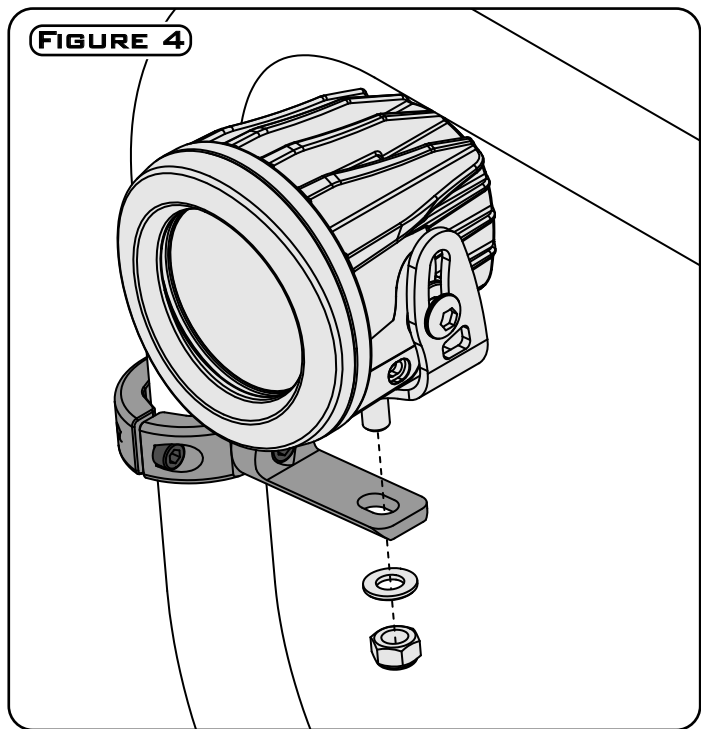

Mounting The Lights

Step Five: Use the hardware supplied with the light pod to mount the light to the shelf.

for all suspension and steering movement.

Caution: It's extremely important to pay close attention to where you mount the lights and how you route the wires.

Step Six: Before operating the motorcycle, turn the handlebars fully left, fully right, and fully compress the suspension. Confirm that the lights do not interfere with operation and that the wires have enough slack to account

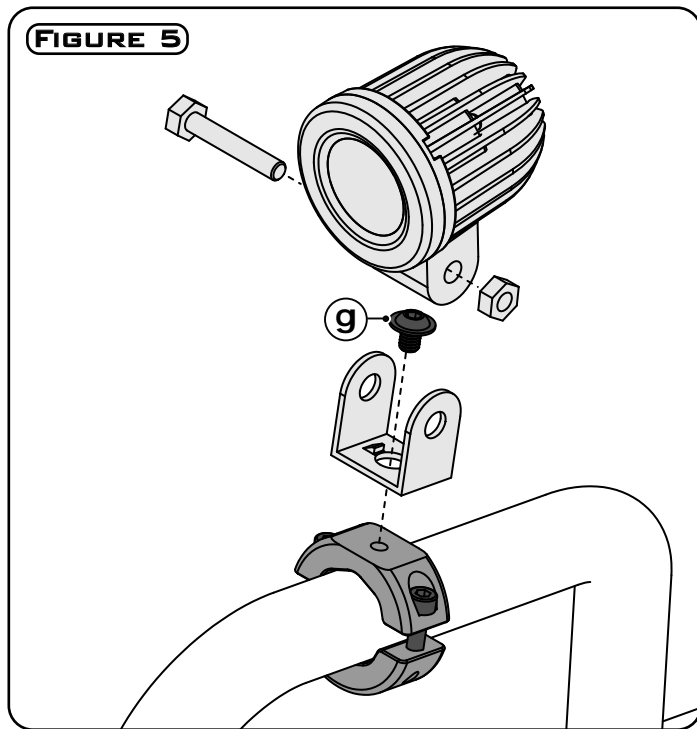

Alternative Mounting Option

In some applications, the most desired mounting location for the light can be achieved by eliminating the light shelf and mounting the light directly to the clamp.

cal and require the lights to be mounted parallel to the ground to properly orient the beam of light.

To mount your light directly to the clamp, first remove the hinge from your light. Next, use the M6x8 lens head screw (g) to mount the lights hinge to the clamp. Then, re-attach the light pod back on to its hinge.

Note: Some beam patterns are asymmetri-