

DENALI™

LAH.00.10000.B

UNIVERSAL PIVOT MOUNT

M5, M6 & M8 MOUNTING POINTS

Thank you for choosing DENALI

We know you would rather be riding your bike than wrenching on it, so we go the extra mile to make sure our instructions are clear and as easy to understand as possible.

Please Read Before Installing

DENALI products should always be installed by a qualified motorcycle technician. If you are unsure of your ability to properly install a product, please have the product installed by your local motorcycle dealer. DENALI takes no responsibility for damages caused by improper installation. **Caution:** When installing electronics is it extremely important to pay close attention to how wires are routed, especially when mounting products to the front fender, front forks, or fairing of your motorcycle. Always be sure to turn the handlebars fully left, fully right, and fully compress the suspension to ensure the wires will not bind and have enough slack for your motorcycle to operate properly.

Installation Tips

We strongly recommend using medium strength liquid thread locker on all screws, nuts, and bolts. It is also important to ensure that all hardware is tightened to the proper torque specifications as listed in your owner's manual. For included accessory hardware please refer to the default torque specifications provided below. Inspect all hardware after the first 30 miles to ensure proper torque specifications are maintained.

Bolt Size	in-lbs	ft-lbs	Nm
M3	10.0 in-lbs	-	1.0 Nm
M4	23.0 in-lbs	-	2.5 Nm
M5	44.5 in-lbs	3.5 ft-lbs	5.0 Nm
M6	78.0 in-lbs	6.5 ft-lbs	9.0 Nm
M8	-	13.5 ft-lbs	18.0 Nm
M10	-	30.0 ft-lbs	41.0 Nm
M12	-	52.0 ft-lbs	71.0 Nm

Hardware Sizing Guide

Not sure what size bolt you have? Use this ruler to measure screws, bolts, spacers, etc. Remember, the length of a screw or bolt is measured from the start of the "mounting surface" to the end of the screw, so only include the screw head when measuring countersunk screws.

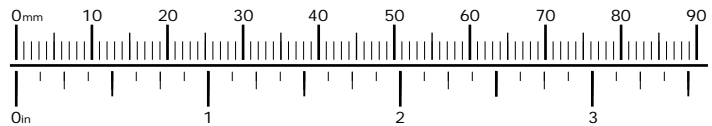
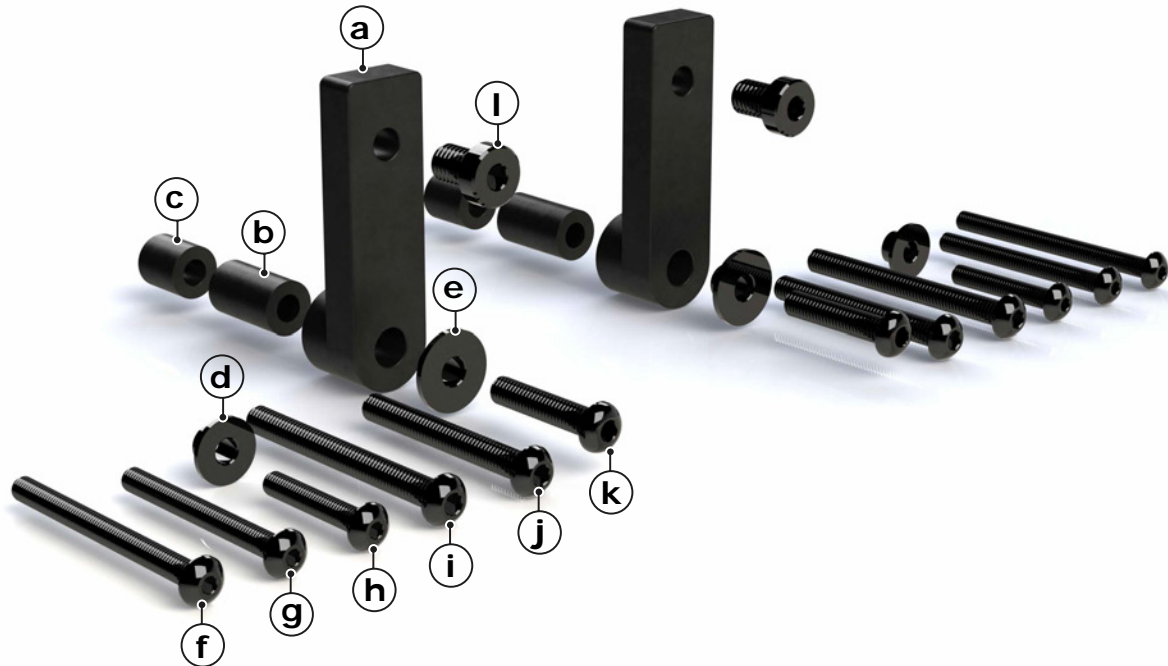

FIGURE 1



Kit Contents

- | | |
|-------------------------------------|------------------------------|
| (a) Bracket.....Qty 2 | (h) M5x30 ISO 7380.....Qty 2 |
| (b) OD:13mm ID:6mm L:22mm.....Qty 2 | (i) M6x60 ISO 7380.....Qty 2 |
| (c) OD:13mm ID:6mm L:14mm.....Qty 2 | (j) M6x50 ISO 7380.....Qty 2 |
| (d) M8 to M5 Bushing.....Qty 2 | (k) M8x30 ISO 7380.....Qty 2 |
| (e) M8 to M6 Bushing.....Qty 2 | (l) M8x12 DIN 7984.....Qty 2 |
| (f) M5x60 ISO 7380.....Qty 2 | |
| (g) M5x50 ISO 7380.....Qty 2 | |

Tools Required

- 5mm Allen Key
- 4mm Allen Key
- 3mm Allen Key
- 13mm Wrench
- 10mm Wrench

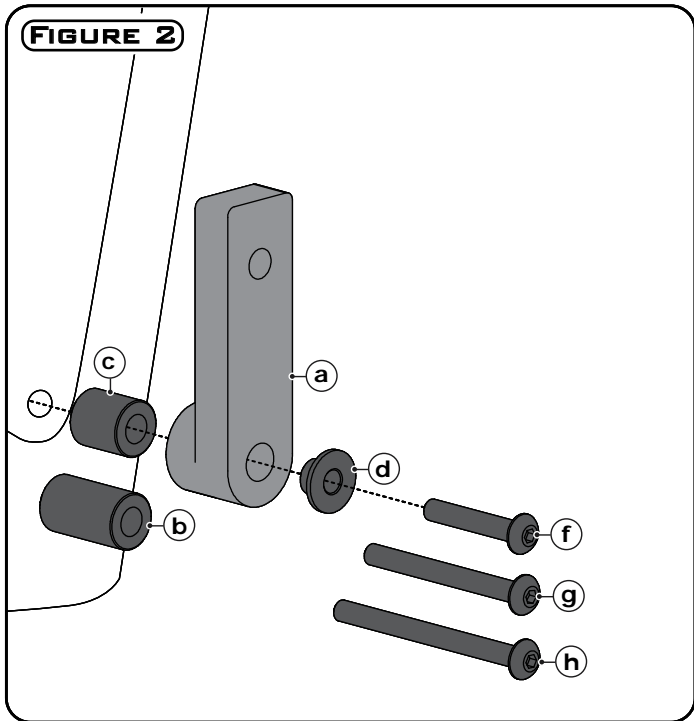

Mounting to an M5 Hole

Step One: If mounting to a M5 hole press the M8 to M5 adapter bushing (d) in the 8mm through hole on the bracket (a).

Step Two: Next adjust the amount of exposed thread to meet your requirements by interchanging the different length M5 bolts (f, g, h) and spacers (b & c).

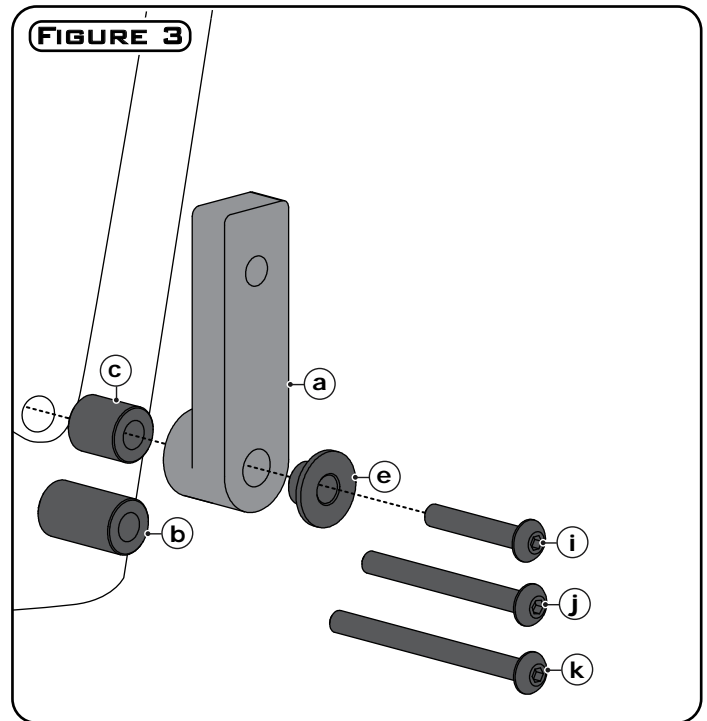

Mounting to an M6 Hole

Step One: If mounting to a M6 hole press the M8 to M6 adapter bushing (e) in the 8mm through hole on the bracket (a).

Step Two: Next adjust the amount of exposed thread to meet your requirements by interchanging the different length M6 bolts (i, j, k) and spacers (b & c).

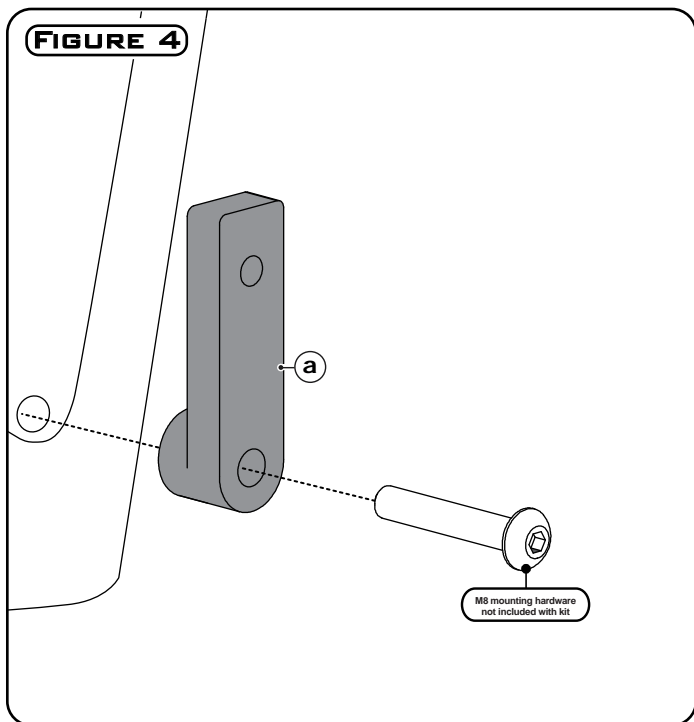

Mounting to an M8 Hole

This kit only includes M6 and M5 mounting hardware, but the bracket (a) will also accept an M8 bolt.

Step One: Adjust the amount of exposed thread to meet your requirements by interchanging different length M8 bolts and M8 spacers. (NOT INCLUDED)

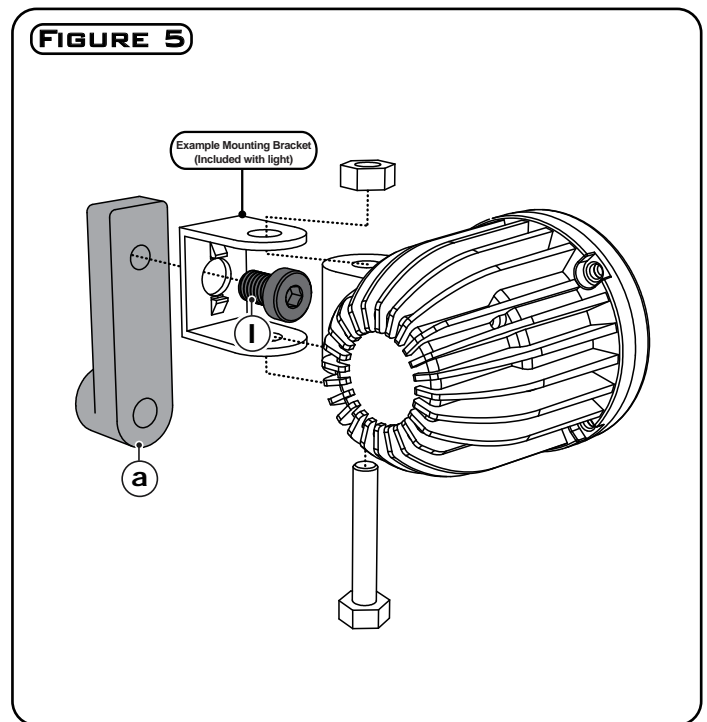

Attaching the Light Pod

Step Three: Remove the mounting hinge from your light pod and remove the original M8 hex head bolt.

Step Four: Once removed, use the included M8x12 bolt (l) to attach the hinge (l) to the threaded hole in the light bracket (a).

Step Five: Re attach the assembled hinge and bracket to your light pod.

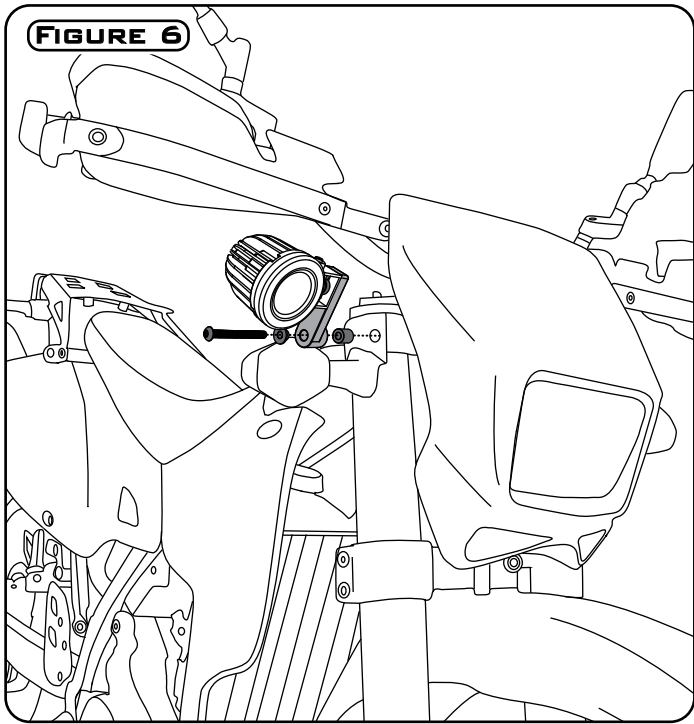

FIGURE 6

Vertical Mounting Example

Note: Be sure that the bracket is only bolted directly to the frame or frame elements of the bike. Do not mount to body clips or plastic fairings that are not directly bolted to the frame.

Caution: Its extremely important to pay close attention to how you route the wires.

Step Six: Before operating the motorcycle, turn the handlebars fully left, fully right and fully compress the suspension. Confirm that

the lights do not interfere with operation and that the wires have enough slack to account for all suspension and steering movement.

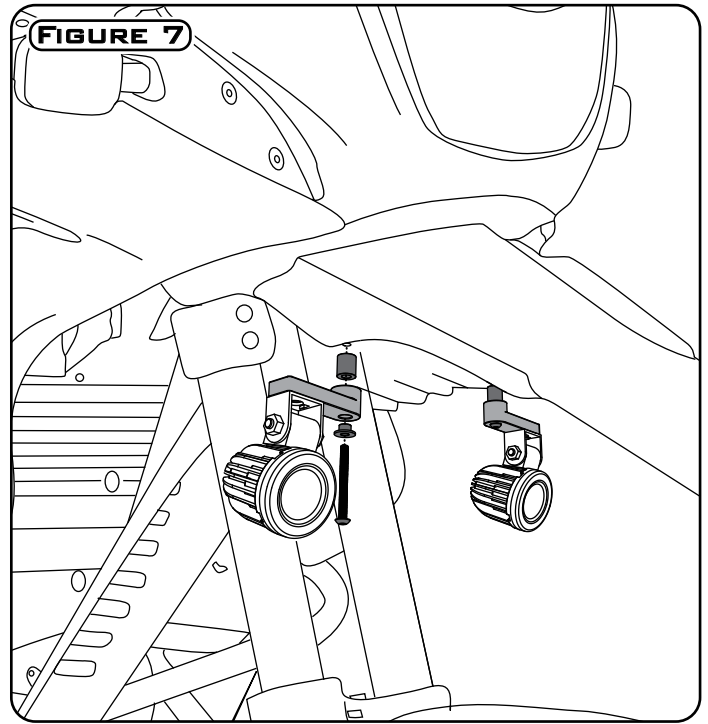

FIGURE 7

Horizontal Mounting Example

Note: Be sure that the bracket is only bolted directly to the frame or frame elements of the bike. Do not mount to body clips or plastic fairings that are not directly bolted to the frame.

Caution: Its extremely important to pay close attention to how you route the wires.

Step Six: Before operating the motorcycle, turn the handlebars fully left, fully right and fully compress the suspension. Confirm that

the lights do not interfere with operation and that the wires have enough slack to account for all suspension and steering movement.