

# Instruction Manual

Instruction Rev00



## T3 Modular Switchback Signal Pods - Rear

DNL.T3.10300

### Thank you for choosing DENALI

We know you would rather be riding your bike than wrenching on it, so we go the extra mile to make sure our instructions are clear and as easy to understand as possible.

### Please Read Before Installing

DENALI products should always be installed by a qualified motorcycle technician. If you are unsure of your ability to properly install a product, please have the product installed by your local motorcycle dealer. DENALI takes no responsibility for damages caused by improper installation. **Caution:** When installing electronics it is extremely important to pay close attention to how wires are routed, especially when mounting products to the front fender, front forks, or fairing of your motorcycle. Always be sure to turn the handlebars fully left, fully right, and fully compress the suspension to ensure the wires will not bind and have enough slack for your motorcycle to operate properly.

### Installation Tips

We strongly recommend using medium strength liquid thread locker on all screws, nuts, and bolts. It is also important to ensure that all hardware is tightened to the proper torque specifications as listed in your owner's manual. For included accessory hardware please refer to the default torque specifications provided below. Inspect all hardware after the first 30 miles to ensure proper torque specifications are maintained.

Bolt Size	in-lbs	ft-lbs	Nm
M3	10.0 in-lbs	-	1.0 Nm
M4	23.0 in-lbs	-	2.5 Nm
M5	44.5 in-lbs	3.5 ft-lbs	5.0 Nm
M6	78.0 in-lbs	6.5 ft-lbs	9.0 Nm
M8	-	13.5 ft-lbs	18.0 Nm
M10	-	30.0 ft-lbs	41.0 Nm
M12	-	52.0 ft-lbs	71.0 Nm

### Hardware Sizing Guide

Not sure what size bolt you have? Use this ruler to measure screws, bolts, spacers, etc. Remember, the length of a screw or bolt is measured from the start of the "mounting surface" to the end of the screw, so only include the screw head when measuring countersunk screws.

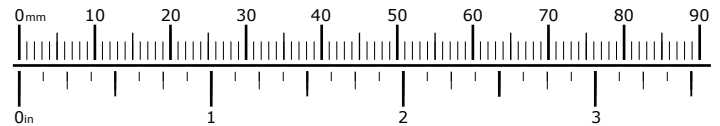

## What's In The Box?

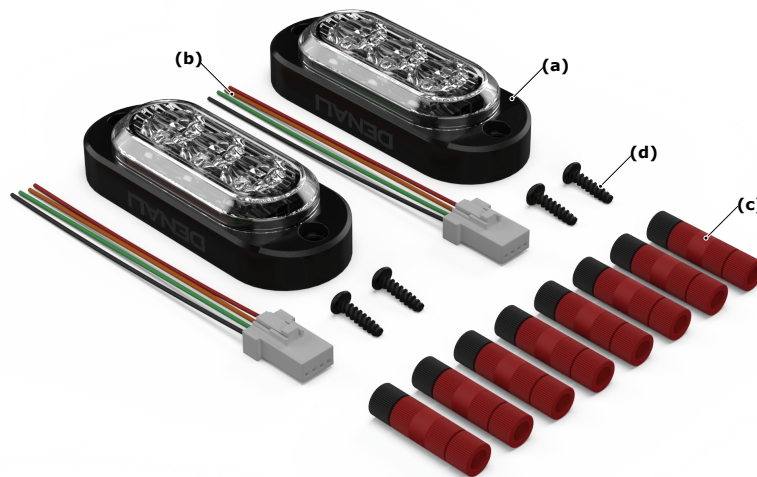

### Kit Contents

- (a) T3 Pod.....Qty 2
- (b) Wiring Pigtail.....Qty 2
- (c) Posi-Tap Connector.....Qty 8
- (d) Self Tapping Screw.....Qty 4

# 1. Connecting To The Vehicle's Factory Harness

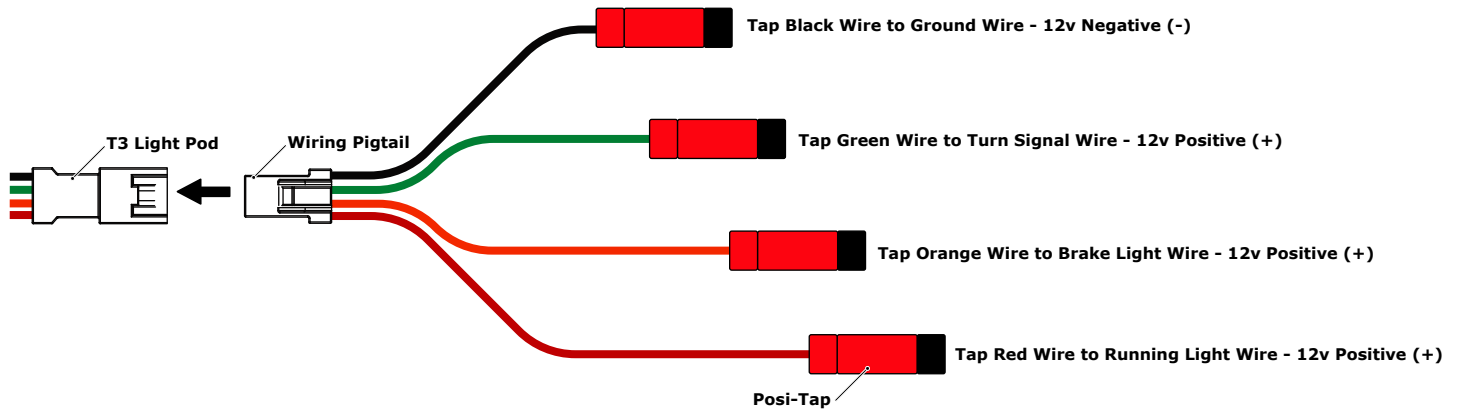

## 1.1 - Wiring The Pigtail

We reinvented the common turn signal to create a shockingly bright amber turn signal with an integrated dual-intensity white DRL.

**Step One:** Route the cable from the T3 Light Pod (a) into the motorcycle to the tail section to the area of the factory brake light and turn signal connectors.

**Step Two:** Identify the vehicle's factory Ground, Turn Signal, Running & Brake Light Wires. Refer to *Section 1.2* for a list of common motorcycle wire colors, or use a voltmeter or multimeter to assist in identifying the correct wires.

**Step Three:** Use Posi-Tap connectors (d) to wire the Pigtail (b) to the wires identified in the previous step.

- Tap the Black Wire to the Vehicle's Ground Wire
- Tap the Green Wire to the Vehicle's Turn Signal Wire
- Tap the Orange Wire to the Vehicle's Brake Light Wire
- Tap the Red Wire to the Vehicle's Running Light Wire or Switched Power

**Step Four:** Plug the Pigtail (b) into the connector of the T3 Light Pod (a).

## 1.2 - Common Motorcycle Wire Colors

**Note:** These listings are meant to be a guide, always check the circuits using a voltmeter before connecting the T3 pods to the motorcycle.

### BMW

- Ground - Brown
- Left Turn Signal - Blue w/ Red Stripe
- Right Turn Signal - Blue w/ Black Stripe
- Brake Light - Yellow w/ Gray Stripe OR Gray w/ Black Stripe & Yellow Dots
- Running Light - DO NOT USE, instead use Red w/ Green Stripe @ Euro Socket

### Harley Davidson

- Ground - Black
- Left Turn Signal - Violet
- Right Turn Signal - Brown
- Brake Light - Red w/ Yellow Stripe
- Running Light - Blue

### Honda

- Ground - Green
- Left Turn Signal - Orange
- Right Turn Signal - Light Blue
- Brake Light - Green w/ Red Stripe OR Green w/ Yellow Stripe
- Running Light - Brown w/ White Stripe

### Kawasaki

- Ground - Black w/ Yellow Stripe
- Left Turn Signal - Green
- Right Turn Signal - Grey
- Brake Light - Blue
- Running Light - Red

### KTM

- Ground - Brown
- Left Turn Signal - Violet
- Right Turn Signal - Black
- Brake Light - Green w/ White Stripe
- Running Light - Yellow

### Suzuki

- Ground - Black w/ White Stripe
- Left Turn Signal - Black
- Right Turn Signal - Light Green
- Brake Light - White w/ Black Stripe
- Running Light - Gray

### Yamaha

- Ground - Black
- Left Turn Signal - Brown
- Right Turn Signal - Green
- Brake Light - Yellow
- Running Light - Blue