

DENALI™

DNL.MBK.10000

PERCH SWITCH MOUNT
DENALI 2.0
 UNIVERSAL

Thank you for choosing DENALI

We know you would rather be riding your bike than wrenching on it, so we go the extra mile to make sure our instructions are clear and as easy to understand as possible.

Please Read Before Installing

DENALI products should always be installed by a qualified motorcycle technician. If you are unsure of your ability to properly install a product, please have the product installed by your local motorcycle dealer. DENALI takes no responsibility for damages caused by improper installation. **Caution:** When installing electronics is it extremely important to pay close attention to how wires are routed, especially when mounting products to the front fender, front forks, or fairing of your motorcycle. Always be sure to turn the handlebars fully left, fully right, and fully compress the suspension to ensure the wires will not bind and have enough slack for your motorcycle to operate properly.

Installation Tips

We strongly recommend using medium strength liquid thread locker on all screws, nuts, and bolts. It is also important to ensure that all hardware is tightened to the proper torque specifications as listed in your owner's manual. For included accessory hardware please refer to the default torque specifications provided below. Inspect all hardware after the first 30 miles to ensure proper torque specifications are maintained.

Bolt Size	in-lbs	ft-lbs	Nm
M3	10.0 in-lbs	-	1.0 Nm
M4	23.0 in-lbs	-	2.5 Nm
M5	44.5 in-lbs	3.5 ft-lbs	5.0 Nm
M6	78.0 in-lbs	6.5 ft-lbs	9.0 Nm
M8	-	13.5 ft-lbs	18.0 Nm
M10	-	30.0 ft-lbs	41.0 Nm
M12	-	52.0 ft-lbs	71.0 Nm

Hardware Sizing Guide

Not sure what size bolt you have? Use this ruler to measure screws, bolts, spacers, etc. Remember, the length of a screw or bolt is measured from the start of the "mounting surface" to the end of the screw, so only include the screw head when measuring countersunk screws.

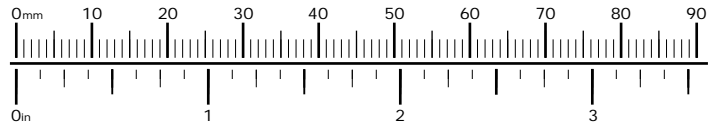

FIGURE 1



Illustration not to scale

Kit Contents

- (a) Angled Plate.....Qty 1
- (b) Flat Plate.....Qty 1
- (c) OD: 9.5 ID: 6.5 L: 14.3.....Qty 1
- (d) OD: 9.5 ID: 6.5 L: 9.5.....Qty 1
- (e) M6x35 DIN 912.....Qty 1
- (f) M5x40 DIN 912.....Qty 1
- (g) No. 4 x 0.25" Phillips Rounded.....Qty 2

Tools Required

- 5mm Hex Allen Key
- 4mm Hex Allen Key
- #1 Phillips Head Screw Driver

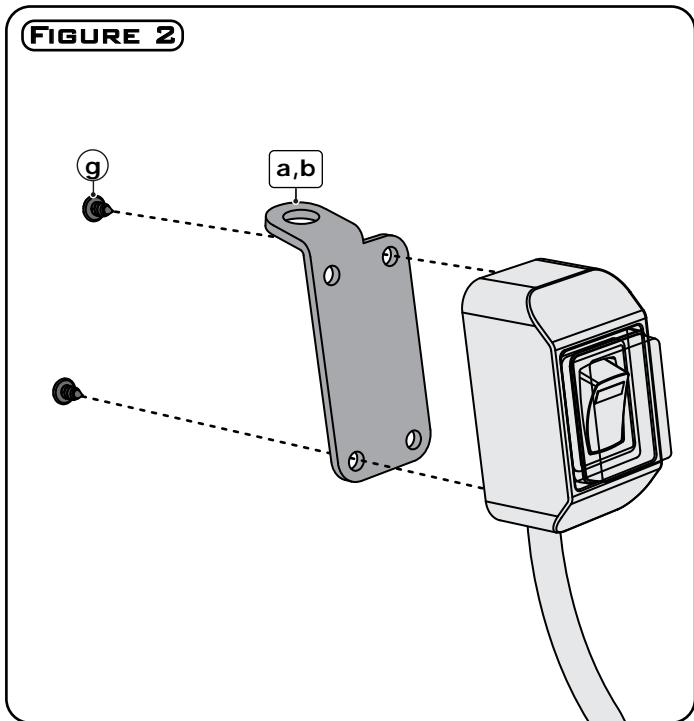

Mounting the Switch to the Plate

Step One: Use a #1 phillips head screwdriver and two No. 4 screws (h) to attach the DENALI 2.0 switch to the mounting plate (a,b).

Note: The angled plate (a) is for mounting to perches with vertical mounting bolts (Figure 4). The flat plate (b) is for mounting to perches with horizontal mounting bolts (Figure 5).

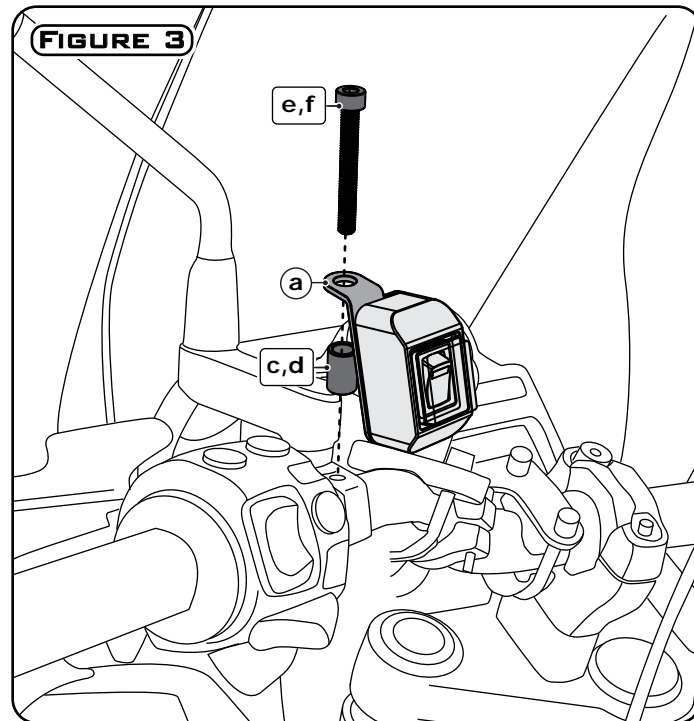

Vertical Perch Mounting

Step One: The plate (a) may be mounted off either perch bolt. Remove the OEM perch bolt that you will be mounting to then determine if the bolt is M5 or M6. Next select the new matching size bolt (e,f) from the hardware included with the kit.

Step Two: Use the new bolt (e,f) and either the long (c) or short (d) spacer or a combination of both spacers to match the thread length of the bolt that was previously removed.

Step Three: Use a Hex key to secure the switch plate (a) to the perch. The bracket may be rotated in any direction to best suit your motorcycle.

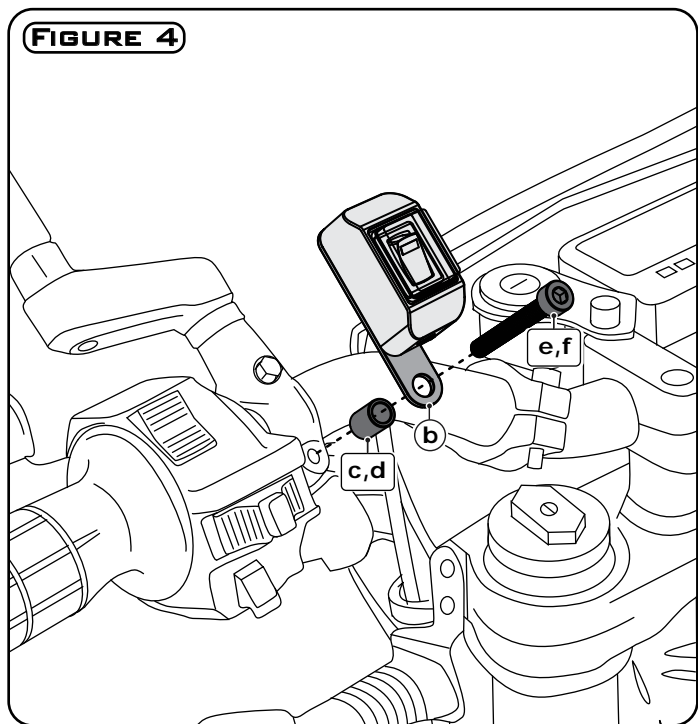

Horizontal Perch Mounting

Step One: The plate (b) may be mounted off either perch bolt. Remove the OEM perch bolt that you will be mounting to then determine if the bolt is M5 or M6. Next select the new matching size bolt (e,f) from the hardware included with the kit.

Step Two: Use the new bolt (e,f) and either the long (c) or short (d) spacer or a combination of both spacers to match the thread length of the bolt that was previously removed.

Step Three: Use an allen key to secure the switch plate (b) to the perch. The bracket may be rotated in any direction to best suit your motorcycle.

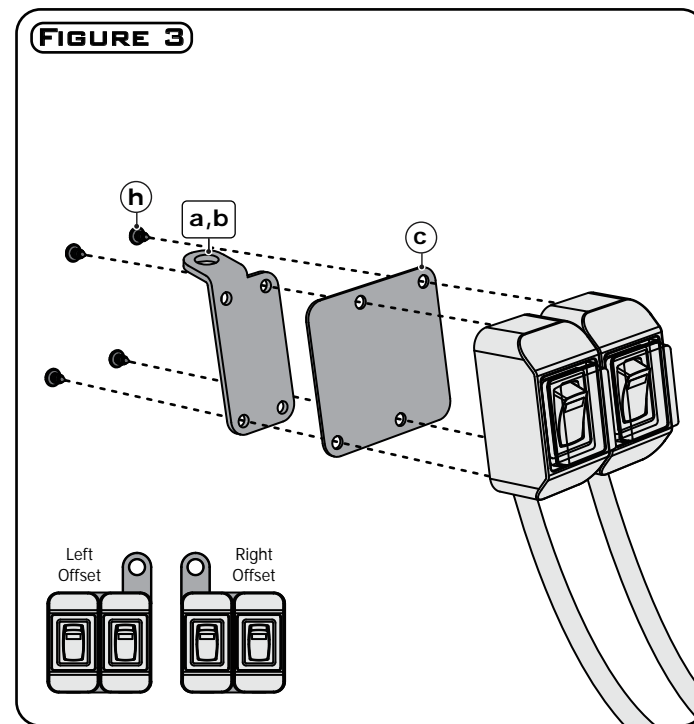

Optional Dual Switch Mounting (DNL.MBK.10100)

Note: Determine which side the switches will be offset from the mounting plate (a,b) before securing the dual mounting plate.

Step One: Use a #1 phillips head screwdriver and two No. 4 screws (g) to attach the first DENALI 2.0 switch to the mounting plate (a,b) with the dual switch plate sandwiched between the two.

Step Two: Use two No. 4 screws (g) to attach the second DENALI 2.0 switch to the

Remaining mounting points on the dual plate.

Note: The Dual Switch Mounting Plate is not included with the Perch Switch Mounting Kit. The Plate is available for purchase separately, part number DNL.MBK.10100.