

Fi2000

Items Supplied >

- 1 – Fi2000R Fuel Injection Module
- 2 – Zip Ties, (1): 3/32" x 6"; & (1): 3/16" x 8"
- 1 – Velcro Strip

Application(s) >

SUZUKI BOULEVARD C90 2005 & UP

Instruction Manual >

92-1840

Page 1 of 4

Read all instructions carefully and completely before installing your new Fi2000R module. It is recommended that a qualified mechanic or technician install this product. Before installing the Fi2000R it is recommended that the gas tank be low on fuel.

1. Remove both seats; Open the gas cap access panel, and remove the 4 upper and 2 lower Allen head bolts and the 3 Philips screws that surround the gas cap. Temporarily remove the gas cap.
2. Remove the 2 front console Allen head screws, lift the console enough to unplug the wiring from the console, and then remove it. Remove the two front steering neck covers, and then remove both dummy gas tank sides.
3. Loosen both air box clamps; unplug the temp sensor from the front right side by pressing the green tab inward, lift the air box up at the front enough to unplug the breather hose. Disconnect the lower breather hose and lift the air box away.
4. Locate the rear injector on the right side, under the frame cross rail. Feed the wire harness of the Fi2000R from the forward left side, back and over the throttle cables and then around the throttle body. Unplug the black connector from the rear fuel injector by squeezing both sides of the connector. Plug the longest matching Fi2000R connector into the injector, (Fig. 1.) Plug the original connector into the corresponding Fi2000R connector, and then tuck this connection back underneath the frame rail.
5. Route the Fi2000R harness between the connectors along the hydraulic clutch line, (black steel tube about 3/16" diameter), and zip tie it so it clears the throttle linkage. Then disconnect the front fuel injector connector and attach the Fi2000R just like the rear, (Fig. 2.)
6. Velcro the Fi2000R module to the outside of the factory ECU with the wires pointing downwards, then remove the front bolt of the ignition coil, slip the ground ring of the black wire from the Fi2000R in between the frame and coil spacer, (Fig. 3.) Replace and tighten the bolt.
7. Confirm there is no interference of the Fi2000R wiring and throttle linkage, (Fig. 2), then replace the air box with its hoses, and wires. Before reinstalling the remaining bodywork verify all connections, (to do this, the dash must be temporarily plugged in to operate the key.)
8. Remove the door from the Fi2000R module to expose the LED's. Verify the wire connections by, (1), turning on the ignition while watching the 3 LED's. They will all light up for a few seconds, and then go off. This is correct. If there are no lights visible, make sure the side stand is up, bike is in neutral, clutch is in and handle bar engine switch is set to run. -- (Continued next page)

*** Cobra recommends you always wear a helmet while riding. Please never operate your motorcycle while under the influence of alcohol and/or drugs. Enjoy the new look of your motorcycle and please ride safely.**

8. Cont. If there are still no lights visible, re-check that all connectors are fully engaged and the ground wire is connected correctly. (2), After achieving a steady light from all three LED's, start the motorcycle; the green light should now be the only LED on. If all three LED's are still on after start up, verify the injector connectors are correctly attached. Reattach the access door when finished and install seat. **Note:** Make sure the ignition is turned off before changing any connection.

ADVANCED TUNING

The Fi2000R has the ability to efficiently tune the EFI system on your motorcycle for slip-on or full exhaust systems. It comes pre-set from the factory for popular brand name slip-on mufflers. Both dyno testing and on-road exhaust gas analysis have been used to develop the best base settings for drivability and power.

Not all slip-on mufflers flow exactly the same. Some eliminate power valves and others don't. Some are made with street baffles, other with race or competition baffles. Full exhaust systems offer even greater variation in construction, features and performance. The Fi2000R has the ability to tune the EFI system on your motorcycle to any of these exhausts by applying a logical and systematic approach to altering the base settings supplied with your Fi2000R. These suggestions should be followed step by step and help you achieve success.

**** Only attempt adjustments on a fully warmed motor ****

1. Start with the base setting, even if you have a full exhaust system. Adjust and test only ONE adjustment pot at a time until you are happy with the result.
2. Start with the left hand or green light pot. This adjustment works either from idle or above idle (varies with bike) to a R.P.M. of about 5000 (also varies with bike) while the bike is driven at a steady throttle or slowly increasing throttle. This is the cruise range and is where the emissions leanness creates issues like choppy on-off throttle application, surging, and backfiring on trailing throttle.
3. Turn this pot back to zero, and make one position increases until you feel the best performance in this range. Do this test a few times to make sure you have it right.
4. The middle or yellow pot is an engine load- triggered fuel adding adjustment. A rapid increase of the throttle at any R.P.M. will add additional fuel and as long as that predetermined load is present, fuel will continue. As engine loads increase in higher gears the acceleration fuel will stay on longer and be more effective. Starting with the base setting, test ride the motorcycle in 4th or 5th gear and perform moderately fast roll-on throttle from a repeating standard R.P.M. or speed. Increase the pot one position at a time and stop as soon as you don't feel any improvement.
5. The right hand or red pot is for the fuel setting required when the engine is maximizing its R.P.M. and power delivery. This pot is similar to the main jet in a carburetor. It will take a combination of a minimum R.P.M. and a predetermined amount of engine load to initiate this fuel. The straightaway on a racetrack or an inertia dyno are the best places to set this pot. Full exhaust systems of high quality construction increase flow characteristics and will increase fuel demands over our base settings. Also, air filters specifically designed for higher than stock airflow can create need for higher fuel setting. Try an additional one-position pot setting at a time.
6. Camshaft changes or major air box modifications can alter an engine's volumetric efficiency and create a greater demand on the engine's fuel system than the Fi2000R may have the ability to adjust for.

TROUBLE SHOOTING

If you have any problems refer to: step 8, in the installation body of these instructions.

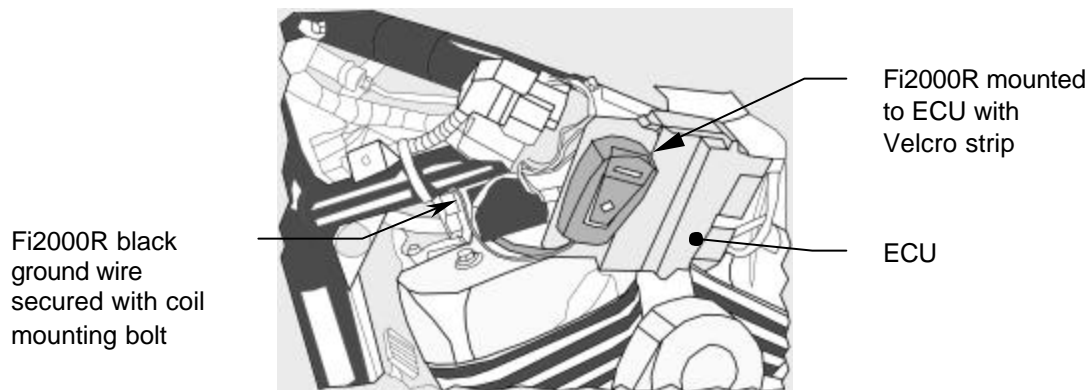
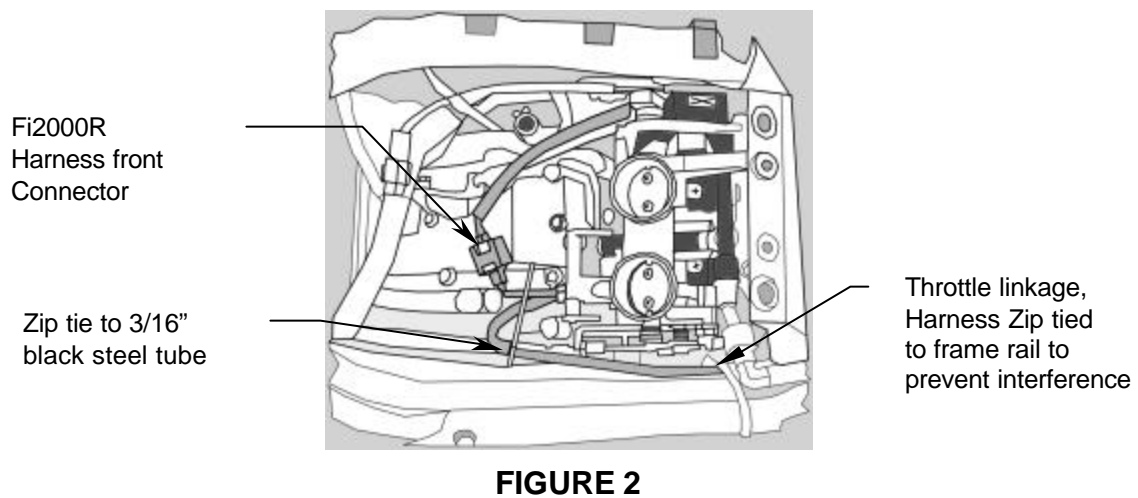
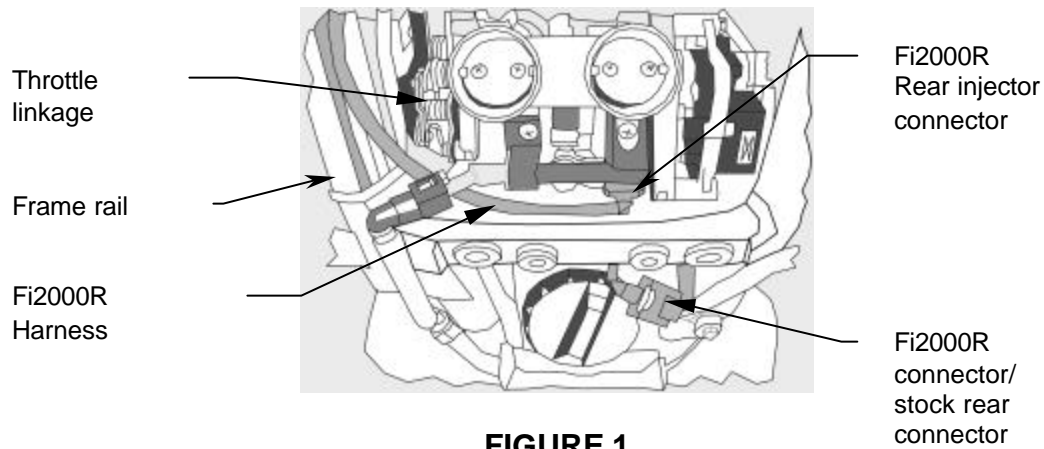

Default Pot Settings:

3.5 5 3.5

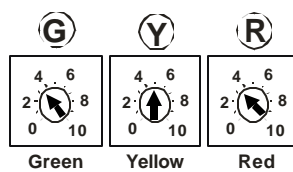

FIGURE 4