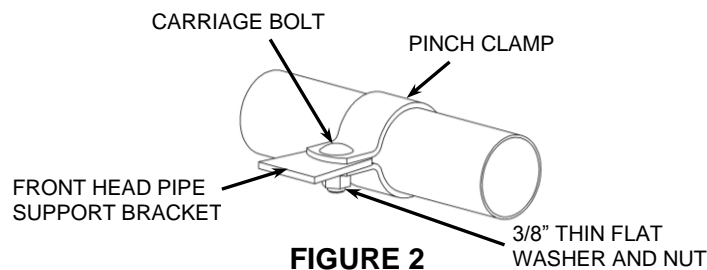
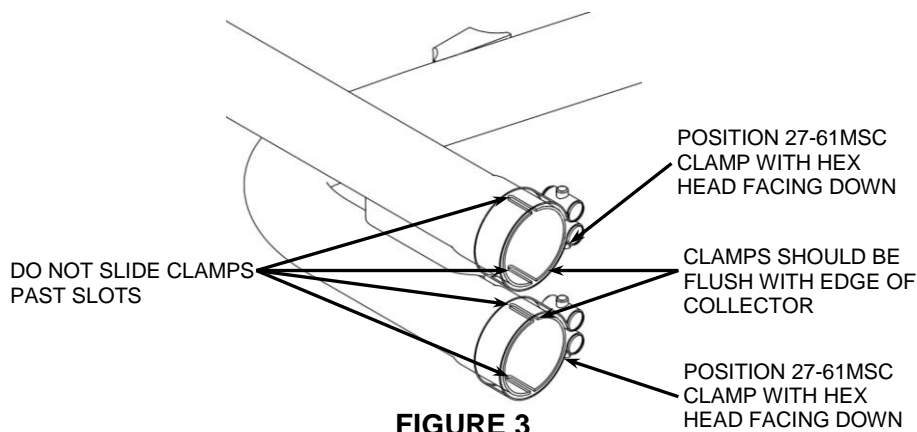

6. Install the stock flanges, retaining rings and O₂ sensors onto the supplied front and rear headpipes. Be sure to install the front O₂ sensor on the front headpipe and the rear O₂ sensor on the rear headpipe.
7. Install the front headpipe (with stock gasket in place) onto the front cylinder using the stock nuts. Snug the nuts but **DO NOT TIGHTEN** at this time.
8. Slide the supplied pinch clamp over the front headpipe making sure the square hole on the clamp is facing up and towards the inside. Position the clamp over the support bracket so that the pinch clamp captures both sides of the bracket. See **FIGURE 2**. Insert the supplied 3/8" carriage bolt through the top of the pinch clamp and support bracket. Install the 3/8" thin flat washer and nut onto the bottom of the carriage bolt but **DO NOT TIGHTEN** at this time.

**FIGURE 2**

9. Install the rear headpipe (with stock gasket in place) onto the rear cylinder using the stock nuts. Snug the nuts but **DO NOT TIGHTEN** at this time.
10. Position 2 of the supplied #27-61 MSC muffler clamps onto the crossover assembly inlets. The hex head of both clamps should be inward and down. See **FIGURE 3**. (NOTE: The clamps should be flush with the end of the crossover assembly inlets when tightened. See **FIGURE 3**. If the clamps are slid past the slots on the crossover assembly inlet the clamps will not tighten properly).

**FIGURE 3**

11. Make sure the front and rear headpipes are parallel with each other and then slide the crossover assembly onto the headpipes by tapping on the headpipes with your hand as you push the crossover assembly forward. Make sure the crossover assembly slides as far forward as possible. See **FIGURE 4**. Lightly snug the 27-61MSC clamps around the expanded inlets but **DO NOT TIGHTEN** at this time. NOTE: Make sure the rear headpipe is aligned parallel with the top tube of the crossover assembly. With the crossover assembly installed, the rear headpipe and top tube of the crossover should make a straight line.

Continued on Page 3

NOTE: Arrows point to the position of the hex head of the clamps.



27-61 MSC CLAMP

FIGURE 4

12. Install the supplied crossover support bracket to the stock mounting location using the (2) stock allen bolts. Lightly snug the bolts but **DO NOT TIGHTEN** at this time. Adjust the crossover pipe assembly fore and aft so the mount on the crossover assembly rests flush against the support bracket. Then push up lightly on the left side of the crossover assembly to align the bracket and insert the stock 5/16 hex flange bolt. Lightly snug the bolt but **DO NOT TIGHTEN** at this time. See **FIGURE 5**. **IMPORTANT: DO NOT** force the crossover assembly into position. If a lot of force is needed to align the crossover tube and support bracket then adjust the rear headpipe and crossover assembly until it will align with only enough force to counter act the weight of the left side of the crossover assembly. Also, Make sure the crossover assembly has clearance all around and does not make contact with the transmission pan; adjust as needed while bolts are loose.



FIGURE 5

13. Slide the supplied clamps over the inlets of the right and left mufflers. Position them as shown in **FIGURE 6** with the hex head facing inward and towards the ground.

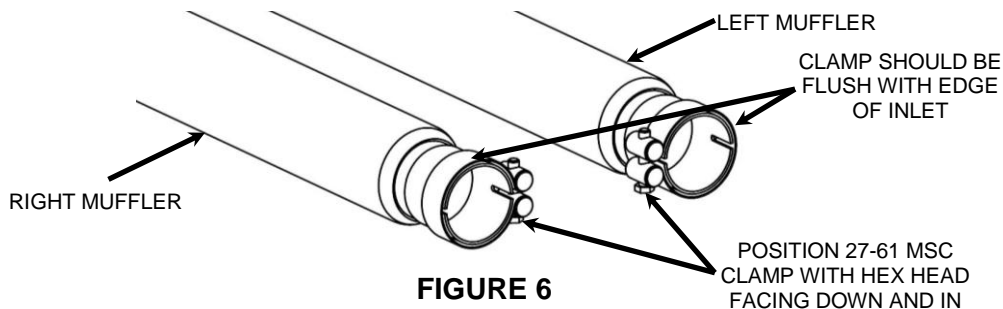
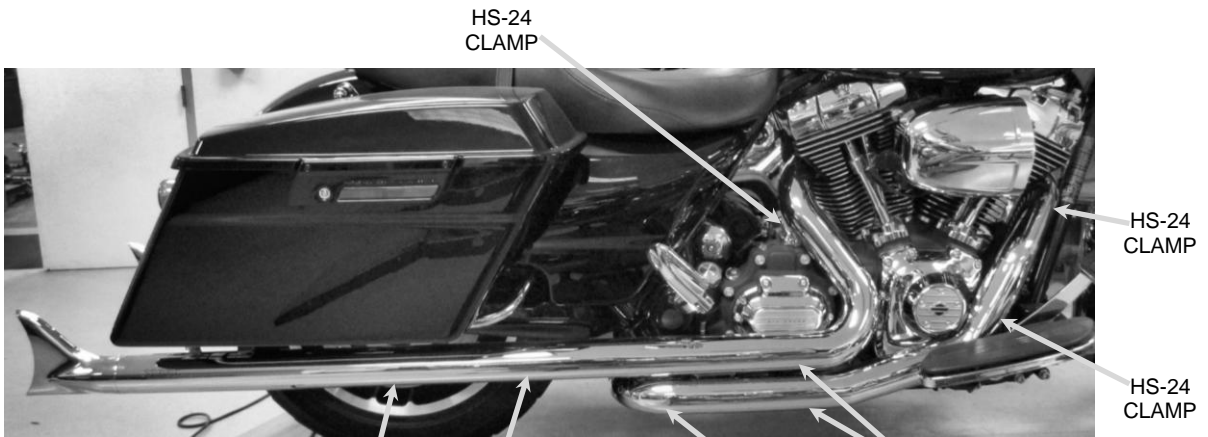

FIGURE 6

Continued on Page 4

14. Install the mufflers onto the crossover pipe assembly and insert the (2) stock 5/16-inch bolts into each rear muffler mount the same as stock. **Do not tighten** clamps or bolts at this time.
15. Make sure the headpipes, crossover assembly, and mufflers are aligned properly and tighten the (2) allen bolts on the crossover support bracket and the 5/16 hex bolt. See **FIGURE 5**.
16. Then fully tighten the flange nuts on the exhaust port studs, followed by the 3/8" carriage bolt and nut on the front headpipe support clamp. See **FIGURE 2**.
17. Next fully tighten the (2) 27-61MSC clamps on the crossover assembly. (NOTE: The clamps should be flush with the end of the crossover assembly inlets when tightened. See **FIGURE 3**. If the clamps are slid past the slots on the crossover assembly inlet the clamps will not tighten properly).
18. From the rear, rotate the mufflers as needed so they are level with the ground and parallel with each other. Then tighten the clamps and the mount bolts. (NOTE: The clamps should be flush with the end of the crossover assembly inlets when tightened. See **FIGURE 6**. If the clamps are slid past the slots on the crossover assembly inlet the clamps will not tighten properly).
19. Plug the O₂ sensors back into the motorcycle wire harness and route the wires away from the exhaust in the same manner as stock.
20. Remove the heatshields and hose clamps from packaging. Unscrew the hose clamps and feed the tail end of the clamps through the clips on the inside of the heatshield so the screws are accessible with a screwdriver once the heatshield is installed. The larger HS-28 clamps go to the rear of the heatshield where they will rest on the muffler body. The smaller HS-24 clamps go on the front of the heatshields where they will rest on the headpipes. See **FIGURE 7 & 8** for proper positioning of the clamps on the heatshields. (NOTE: The arrows point to the positioning of the hex head of the clamps. The hex head of the clamps should be accessible for tightening but not visible when the heatshields are mounted to the pipes.)
21. Install the right rear heatshield over the rear headpipe by first sliding the rear portion of the heatshield over the muffler. Continue to slide the heatshield forward while pushing the front of the heatshield gently between the motor and frame. (Hint: Spread the hose clamps apart slightly to make it easier to slide them over the headpipes.) Make sure the muffler clamps do not interfere with the heatshields and are aligned as shown in **FIGURE 6**. Align the heatshield with the headpipe and snug the clamps but **DO NOT TIGHTEN** at this time. See **FIGURE 7**.
22. Install the right front heatshield over the right front headpipe. (Hint: Spread the hose clamps apart slightly to make it easier to slide them over the headpipes.) Align the heatshield with the headpipe and snug the clamps but **DO NOT TIGHTEN** at this time. See **FIGURE 7**.
23. Install the left rear heatshield over the left rear muffler and crossover headpipe by first sliding the rear portion of the heatshield over the muffler. Continue to slide the heatshield forward while pushing the front of the heatshield gently into position. (Hint: Spread the hose clamps apart slightly to make it easier to slide them over the headpipes.) Make sure the muffler clamp does not interfere with the heatshield and are aligned as shown in **FIGURE 8**. Align the heatshield with the muffler and crossover headpipe and snug the clamps but **DO NOT TIGHTEN** at this time.
24. Align the threaded holes in the side of the fishtail tip with the holes in the muffler heatshield and slide it into the rear of the heatshield and muffler. (NOTE: If it is difficult to slide the tip into the heatshield loosen the clamps on the muffler heatshield. Failure to do this may cause damage to the tips.) Fasten the tip with (2) of the supplied ¼-20 button head screws making sure there is no gap between the tip and muffler heatshield when tightened. Do this for both left and right sides.
25. Make sure the rear of both fishtails tips are even on the back with each other.
26. Once the tips and heatshields are aligned properly tighten all hose clamps securing the heatshields.

Continued on Page 5



NOTE: Arrows point to the position of the hex head of the clamps.

HS-28 CLAMP HS-24 CLAMP **FIGURE 7** HS-24 CLAMP HS-24 CLAMP



FIGURE 8

NOTE: Arrows point to the position of the hex head of the clamps.

Continued on Page 6

27. Insert the supplied floorboard spacer plate between the rear floorboard mount and the frame, then align the dowel pin and reinstall the allen bolt. Tighten to factory specifications. See **FIGURE 9**.
28. Remove the allen bolt from the right front floorboard mount. Place the supplied thick washer between the front floorboard mount and the frame. Reinstall and tighten the allen bolt to factory specifications. See **FIGURE 9**.

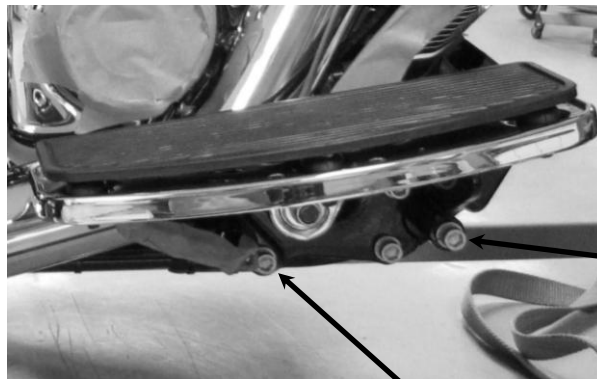

FIGURE 9

INSTALL SPACER
PLATE ON REAR
MOUNT

INSTALL THICK 3/8"
FLAT WASHER ON
FRONT MOUNT

29. Reinstall any other previously removed items. Tighten to factory specifications.
30. Make sure all the hardware (brackets, headpipes, heatshields, mufflers and floorboards) have been tightened appropriately.
31. **IMPORTANT:** Before starting your engine remove all fingerprints from chrome with a quality wax or chrome polish. Failure to do so can cause chrome discoloration. Due to fluctuations in fuel delivery settings, timing, etc., Cobra Engineering does not warrant against chrome discoloration.

IMPORTANT: If your motorcycle is equipped with fuel injection it is recommended that you install a Cobra Fi2000® Digital Fuel Processor with your Cobra exhaust system.

DISCLAIMER: NOT LEGAL FOR SALE OR USE IN CALIFORNIA ON ANY POLLUTION CONTROLLED MOTOR VEHICLES.