

Items Supplied >

- 1 – Fi2000 Fuel Injection Module
- 1 – Velcro Strip
- 1 – Ziptie 8"
- 2 – Ziptie 14"

Application(s) >

HARLEY DRESSER

17-18

Instruction Manual >

692-1631CL

Page 1 of 4

Read all instructions carefully and completely before installing your new Fi2000 module. It is recommended that a qualified mechanic or technician install this product.

1. It is recommended to have the motorcycle positioned on the kickstand or a motorcycle stand with the handlebars in a straight forward position for accessing components for Fi2000 module installation. Remove the right side saddlebag, being careful not to scratch chrome or paint.
2. Remove right side cover and seat to expose engine ECU and oxygen sensor connectors.
3. Disconnect electrical connector and vacuum line on the upper left side of frame behind rear of fuel tank and remove the two bolts securing rear of fuel tank. Pull the vacuum line running down right side of frame upward so it can be removed with tank, see Figure 1. Disconnect the dry-break fuel line from the bottom of the fuel tank by pulling the outer ring upward and then the fuel line / fitting downward. At the front of the fuel tank remove the rubber covers which are installed on the fuel tank's front bolts. With help, remove the bolts and then the entire fuel tank from the motorcycle, set in a secure area to prevent any damage to the tank or paint.
4. Place the Fi2000 case and harness on right side of the motorcycle between the large wire harness and ABS control block, under the right side panel area, see Figure 2. Route the main fuel injector harness and ground wire under the right frame rail and upward to under seat area. Open the plastic wire loom sheath by removing cutting the black tape securing it closed. Place the injector harness inside of it, towards the right side, route connectors forward to area between cylinder heads, see Figure 3.
5. Disconnect the stock front female injector connector and mate a pair of the Fi2000 connectors to the front injector by installing the Fi2000 female connector on to the front injector and stock front female connector to Fi2000 male connector. See Figure 4.
6. Mate the other pair of connectors to the rear injector in the same manner as the front injector, See Figure 4.
7. Now locate the oxygen sensor connectors along the right rear frame rail where the right side cover was removed just to the rear of the ABS block. Route the Fi2000 oxygen sensor harnesses to this area. Be sure to route them between the large wire harness and ABS control block. Unplug the light grey set of stock connectors and mate the corresponding male and female Fi2000 connectors to them. Repeat for black set of oxygen sensor connectors. Make sure all connectors seat firmly, see Figure 5.
8. Attach the ground wire from the Fi2000 to the negative battery terminal. Velcro the Fi2000 case to the side of the ABS control block, see Figure 2.
9. Secure the oxygen sensor connectors to the frame with the longer supplied ziptie, see Figure 5. Use the shorter supplied ziptie to secure the fuel injector harness to the existing wire loom near the front.
10. Close the wire loom sheath and secure to frame using large ziptie. Reinstall fuel tank and reconnect (2) electrical connectors, vacuum line and reroute long vacuum line inside of right frame rail. Reinstall front fuel tank bolts to hold fuel tank in place but do not fully tighten or install rear bolts until all F.I. connections have been verified.

DISCLAIMER: NOT LEGAL FOR SALE OR USE IN CALIFORNIA ON ANY POLLUTION CONTROLLED MOTOR VEHICLES.

11. Remove the door from the Fi2000 box to expose the LED's. The pot settings on the Fi2000 must be set to match the proper intake and exhaust configuration - Refer to Figure 6 and the **Advanced Tuning** section to determine the proper configuration. Once the proper pot setting have been chosen set the pot dials using a small flat blade screwdriver. Verify the wire connections by (1) turning the ignition on, prior to starting, and see if all three LED's are on steady. If you have no light, your ground connection (BLACK wire) has not made proper contact or the injector connections are not complete. (2) After achieving a steady light from all three LED's, start the motorcycle, wait 15 seconds and let it idle, the green light should now be the only LED on. If all three LED's are still on after start up, verify you have attached the injector connectors correctly. Reattach the door when finished. **Note:** Make sure the ignition is turned off before changing any connection.
12. Once proper Fi2000 operation has been verified, reinstall the rear bolts securing the fuel tank, and tighten both front and rear bolts securely. Be sure to reinstall the rubber covers on front bolts. Install the right side cover along with the right saddlebag and seat with screws. Verify once more all hardware has been properly tightened.

ADVANCED TUNING

Your Cobra® Fi2000 fuel injection module has been tested and preset for best function and rideability on a motorcycle with aftermarket aircleaner and Cobra slip-on mufflers. If your motorcycle has a different intake and exhaust configuration please read below for the appropriate pot setting, and change the pot dials to these settings. Remove the door to expose the pots shown in Figure 6. The Fi2000 does have 3 important adjustments that allow you to tune the module for optimum performance, especially if you have performed other changes to your motorcycle. These adjustments also allow you to resolve drivability issues if our stock settings are not exactly right for your bike. Make sure your motorcycle is up to normal operating temperature (15 minutes of riding should be sufficient) before making any adjustments.

GREEN LED POT (left pot) – With the Closed Loop function of this module you do not need to adjust this setting, leave it at 1.5. Without a closed loop system this adjustment would affect idle and cruise fuel. If you had cruising issues, this is where you would try a different setting. Generally, surging and uneven running while cruising is a lean fuel condition, so adding a small increase in fuel by turning this adjustment clockwise with a small flat blade screwdriver a 1/2 of a position would help. The bike would need to be Test-driven to feel an improvement and only the setting would need to be increased until the surge went away. Also, backfiring or popping on trailing throttle is generally a lean symptom (or an exhaust gasket leak). The same small increases as above would be tried just until the backfiring would disappear.

YELLOW LED POT (middle pot) - this adjustment affects acceleration and power fuel. If you have a hesitation or bogging on acceleration, this is where you would try a different setting. Aftermarket air cleaner assemblies generally lean out fuel mixtures, so try small clockwise increases as above until a smooth acceleration returns.

RED LED POT (right pot) - this adjustment is the top end or power fuel adjustment. Just like the main jet in a carburetor, it starts to control fuel as you demand maximum power from your bike and takes over completely above 4000 R.P.M. As performance gains are added to your motorcycle, such as big bore kits, camshafts, flowed cylinder heads, etc., each component will increase the fuel demand of the system. With the red pot turned to its maximum (10) position, the Fi2000 will cope with nearly 100 R.W. horsepower. You can generally, if you are using quality performance engine upgrades, in a sensible combination equate the numbers evenly from 2 up to 10 based on horsepower gains.

TUNING NOTES

Typically our full exhaust headpipe systems require one additional increase, however we recommend starting with the settings in Figure 6, and then adjusting the yellow and red pots, should the engine exhibit lean characteristics.

On high performance motors, slip-on mufflers do not flow well enough and create fuel setting problems and detonation. Cobra recommends the installation of any of its complete exhaust systems.

TROUBLE SHOOTING

If you have any problems refer to Step 11 in the main body of the instructions.

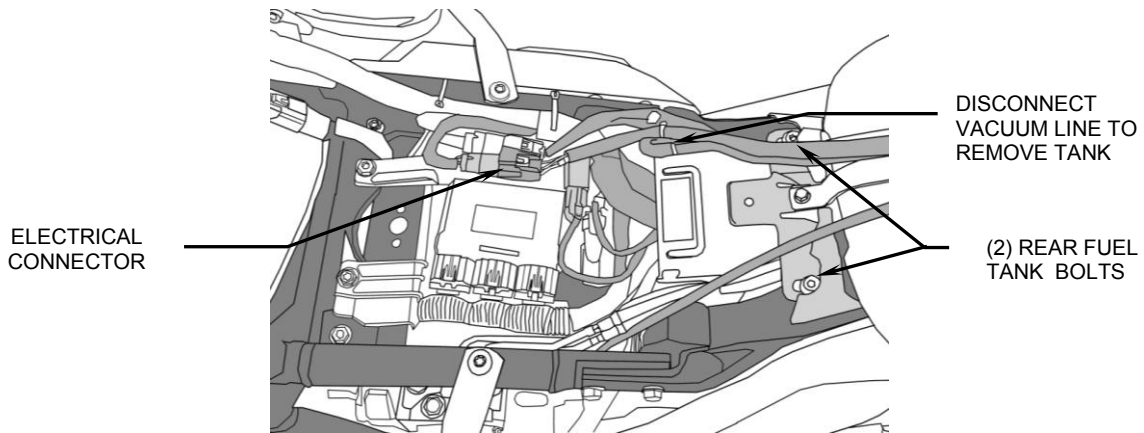

FIGURE 1

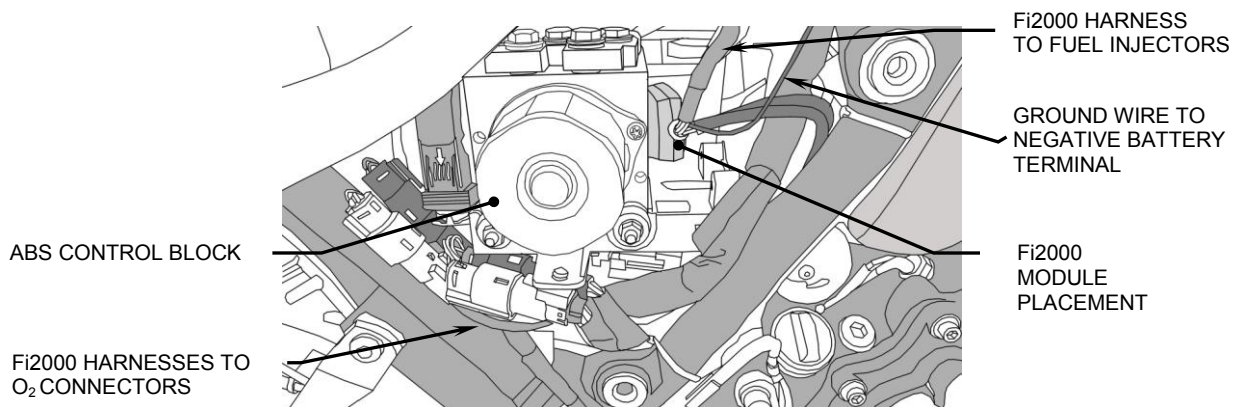

FIGURE 2

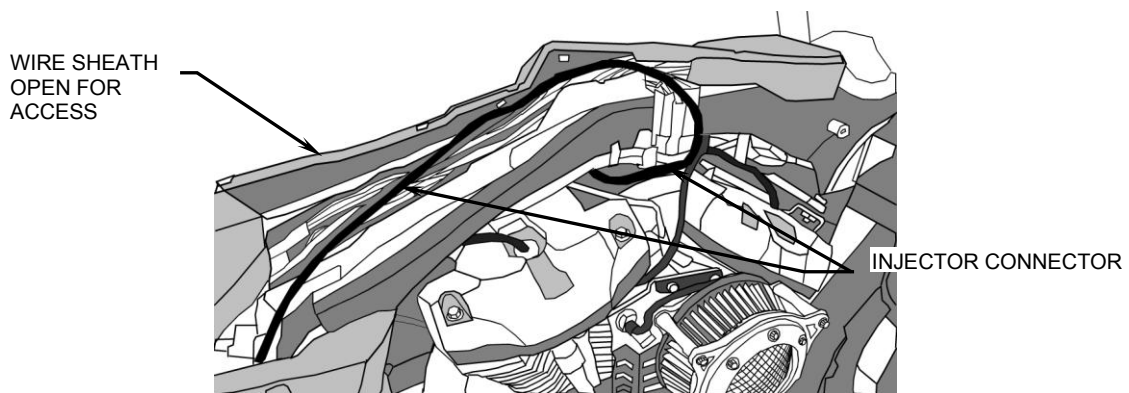
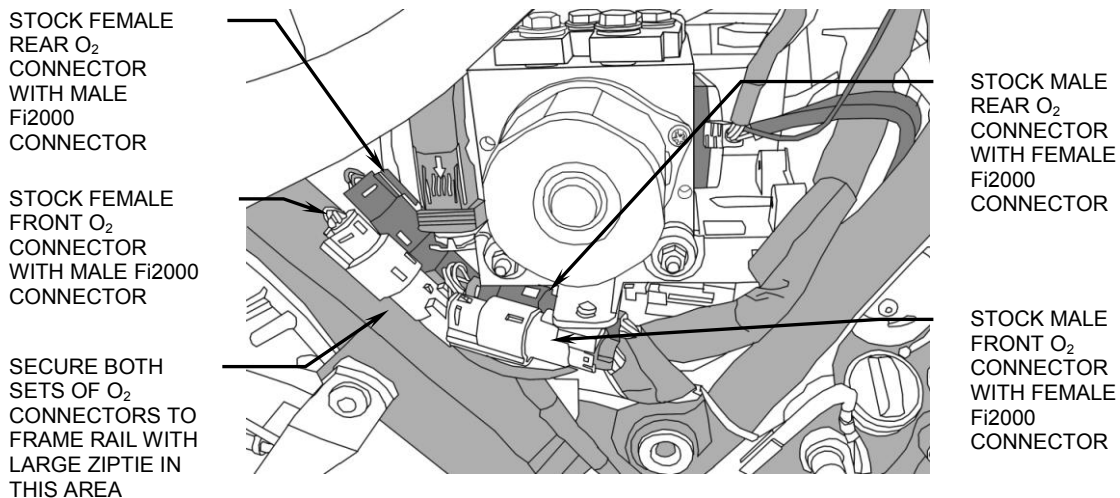
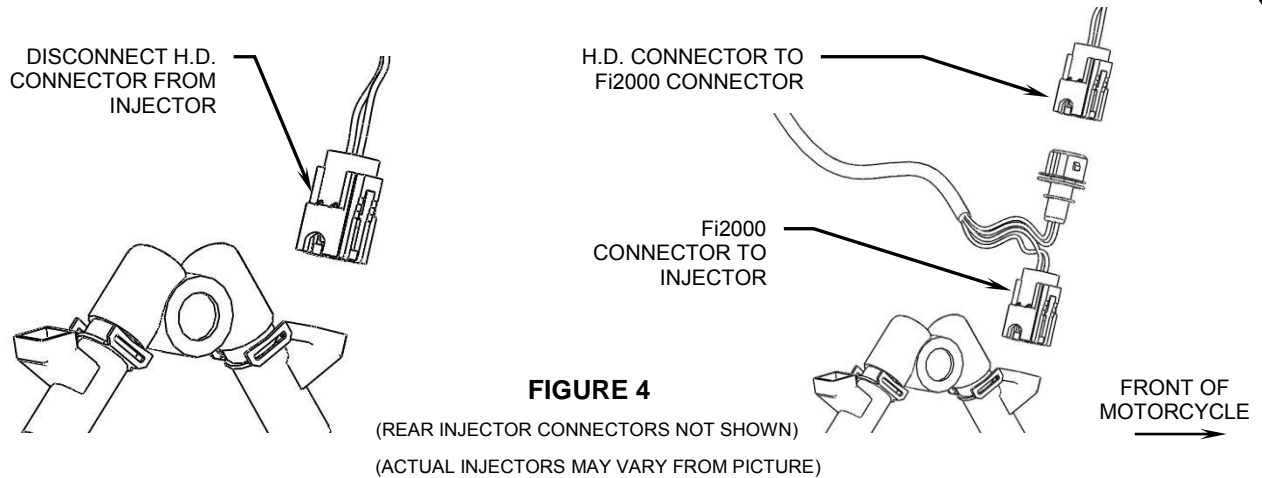

FIGURE 3



Aftermarket Air Cleaner w/ Slip-on Mufflers

Default Pot Settings:

1.5 2.5 0

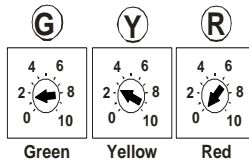

FIGURE 6

DISCLAIMER: NOT LEGAL FOR SALE OR USE IN CALIFORNIA ON ANY POLLUTION CONTROLLED MOTOR VEHICLES.