

Items Supplied >

- 1 – POWRPRO Fuel Injection Module
- 1 – Velcro Strip
- 1 – Ziptie 8"
- 1 – Ziptie 14"

Application(s) >

HARLEY DRESSER 2010-2013

Instruction Manual >

692-1615B

Page 1 of 3

Read all instructions carefully and completely before installing your new POWRPRO module. It is recommended that a qualified mechanic or technician install this product.

1. It is recommended to have the motorcycle positioned on the kickstand with the handlebars at a forty-five degree angle to the left to aid in accessing components for Powrpro module installation. Remove both left and right side saddlebags, being careful not to scratch chrome or paint.
2. Remove right side cover and seat to expose engine ECU and oxygen sensor connectors.
3. Loosen and remove the bolt securing the instrument bezel to the rear of the fuel tank. Remove the plastic shroud at rear of fuel tank, partially covering fuel tank bolts, see Figure 1. Remove the two bolts securing rear of fuel tank. At the front of the fuel tank remove the rubber covers which are installed on the fuel tank's front bolts. Loosen the bolts only 1-2 turns, **do not remove**.
4. Be sure handlebars are at a forty-five degree angle to the left, to prevent instrument bezel from making contact with ignition lock. Locate a small piece of wood or plastic approx. 2 –3" tall and raise the rear of the fuel tank up and secure in place with the block, this will allow access to the fuel injector connectors.
5. Place the Powrpro case and harness on right side of the of the motorcycle between the large wire harness and ABS control block, under the right side panel area, See Figure 2. Route the main fuel injector harness and ground wire under the right frame rail. Place the fuel injector harness between the frame rail and existing wire loom sheath as it goes under the rear of the fuel tank. Route connectors up the main frame rail under the fuel tank to the fuel injectors between the cylinder heads.
6. Disconnect the stock front female injector connector and mate a pair of the Powrpro connectors to the front injector by installing the Powrpro female connector on to the front injector and stock front female connector to Powrpro male connector. See Figure 3.
7. Mate the other pair of connectors to the rear injector in the same manner as the front injector, See Figure 3.
8. Now locate the oxygen sensor connectors along the right rear frame rail where the right side cover was removed. Route the Powrpro oxygen sensor harnesses to this area. Be sure to route them between the large wire harness and ABS control block. Unplug the light tan set of stock connectors and mate the corresponding male and female Powrpro connectors to them. Repeat for black set of oxygen sensor connectors. Make sure all connectors seat firmly, see Figure 4.
9. Attach the ground wire from the Powrpro to the negative battery terminal. Velcro the Powrpro case to the side of the ABS control block, see Figure 2.
10. Secure the oxygen sensor connectors to the frame with the longer supplied ziptie, see Figure 4. Use the shorter supplied ziptie to secure the fuel injector harness to the existing wire loom.
11. Remove the block elevating the fuel tank and lower the tank back into place, be sure the injector harness does not get pinched between the tank and top frame rail.

DISCLAIMER: NOT LEGAL FOR SALE OR USE IN CALIFORNIA ON ANY POLLUTION CONTROLLED MOTOR VEHICLES.

12. Verify that the module has power and connections have been made correctly; watch the clear window on the FI housing and turn "ON" the key ignition and set the handlebar run switch to "ON", confirm that the Red LED turns on. On some models the Red light will turn off after 4-5 seconds as the fuel pump cycles off, which is OK. If you do not see a Red light, it may be necessary to wait for the alarm to reset (if applicable) and try again. Also confirm the side stand is up, bike is in neutral, and clutch is in. Start the bike and confirm the LED remains on solid Red. **NOTE:** Make sure ignition is turned off before attempting to change any Fi2000 harness connections if no Red light is seen. For access to the Blue Tooth Tuning App on the module, please download the PowrPro Black App to your smart device, Android 4.3 & later or Apple iOS 5.0 & later operating systems. Once the app is installed, make sure the motorcycle is in neutral and start the engine, use the connect button within the app and the Blue light on the Fi module window will light up during pairing connection and remain solid Blue while paired and connected with respective Android or Apple Device. Once the app has been used and settings saved and disconnected through the app, the Blue light will turn off, and the PowrPro Black will be ready for continued service on the motorcycle.
13. Once proper Powrpro operation has been verified, reinstall the bolts securing the fuel tank, along with the plastic sheath and instrument bezel bolt. Be sure to tighten the bolts on the front of the fuel tank and reinstall the rubber covers. Install the right side cover along with the left and right saddlebags and seat.

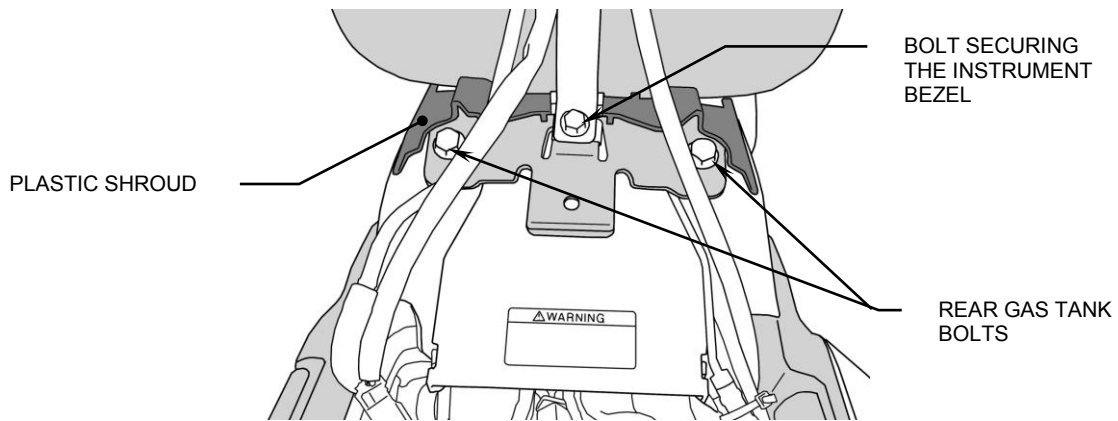
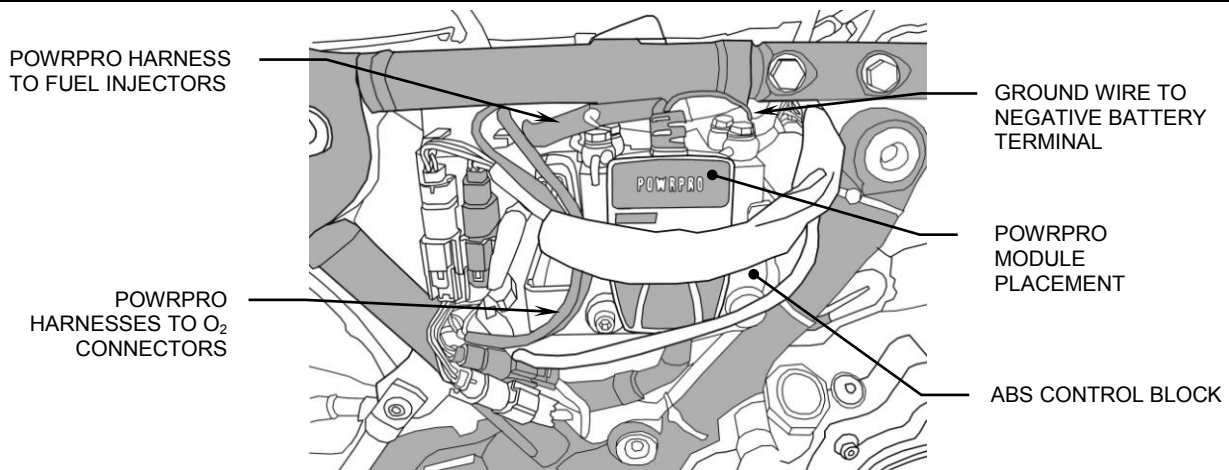
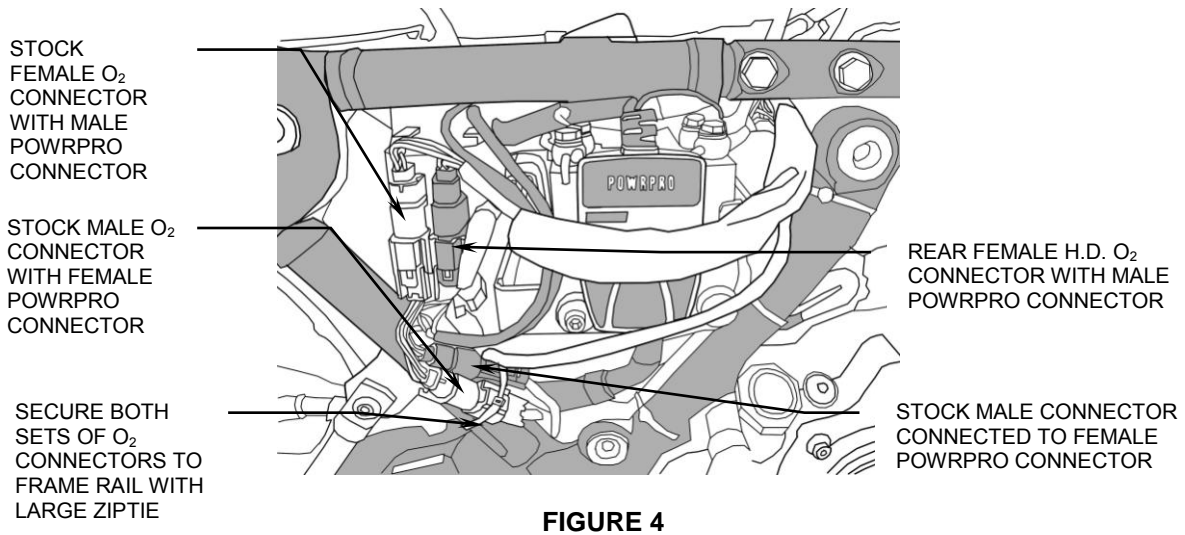
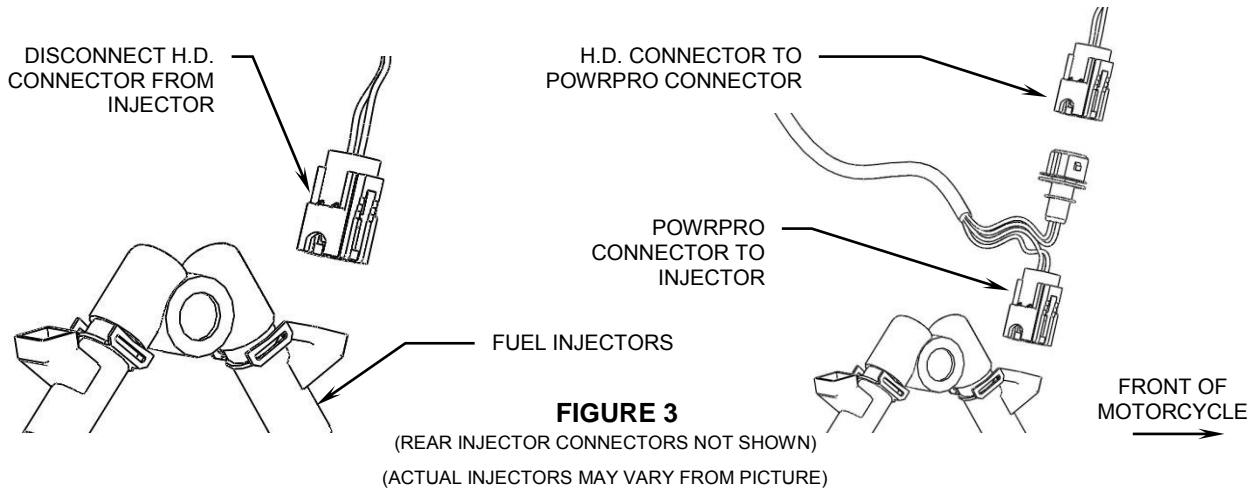

FIGURE 1





DISCLAIMER: NOT LEGAL FOR SALE OR USE IN CALIFORNIA ON ANY POLLUTION CONTROLLED MOTOR VEHICLES.