

Fi2000

Items Supplied >

- 1 – Fi2000CL-ARB Fuel Injection Module
- 6 – Zip Ties 6"
- 1 – Velcro Strip

Application(s) >

HARLEY DRESSER 2007

Instruction Manual >

692-1608CL-50

Page 1 of 3

ATTENTION: All 2007 Harley DRESSER models manufactured before NOVEMBER 1, 2006 require an ENGINE CONTROL MODULE CALIBRATION update from a Harley Davidson Dealer; please reference Harley Davidson SERVICE BULLETIN M-1186. This Fi2000 is meant to function on all 2007 DRESSER models with this update and all 2007 DRESSER models manufactured after this date which should already have this update installed, check with your local dealer for verification.

Read all instructions carefully and completely before installing your new Fi2000CL-ARB module. It is recommended that a qualified mechanic or technician install this product.

1. Remove the seat and air cleaner assembly. Remove rear mounting bolt from fuel tank and prop the fuel tank as high as it will comfortably go.
2. Locate the factory connector on each fuel injector. Depress the tab on the connector and pull the connector free from the injector and move it out of the way. **Note:** A pair of needle nose pliers and a long flat blade screwdriver helps with this job, see Figure 1.
3. Lay the Fi2000 module in the open area just behind the fuel tank, Figure 2. By carefully prying the 3 locking tabs, open the right side of the black plastic runner that houses the stock wiring harnesses. Slip the Fi2000 harness into the runner; use the cutout on the left side towards the rear of the runner to feed the harness into it. Route the harness forward about 6 inches and then have it exit at the right side of the runner. Snap the top of the plastic runner back into place.
4. Route the Fi2000 module's forward injector plug, with the red and brown wires behind the existing wires and under the upper motor mount assembly. Connect the Fi2000 gray connector onto the injector and insert the black connector into the original Harley connector, Figure 1.
5. Attach the Fi2000 module's rear female injector plug, with the red and green wires, onto the rear injector. Then take the original female HD connector and insert the corresponding male Fi2000 connector, refer to Figure 1. Tuck both front and rear injector connections out of the way.
6. It is now time to install the oxygen sensor harnesses. In the open area where the Fi2000 module has been placed you will see a round hole (approximately 1" in diameter), in the lower area of the frame. Feed the two O₂ sensor harnesses through this hole. Above the transmission on the right side locate the stock rear O₂ sensor connection. Unplug this and plug the corresponding Fi2000 connectors from the shorter Fi2000 O₂ sensor harness into these connectors see Figure 3.
7. Route the longer O₂ harness through the factory loop holding the rear brake hose then up the right side of the bottom frame rail and ziptie it in 3 locations.
8. Route the harness behind the rear brake assembly and then up the front right frame downtube so the connectors end up at the cross member where the front O₂ connection is located. Ziptie the Fi2000 harness to the right downtube. Cut the 2 zipties holding the factory connection, unplug the connection, and then plug in the corresponding Fi2000 connectors into the factory connectors. Re-ziptie both connections along the frame cross member, using the original ziptie holes, Figure 4.

*** Cobra recommends you always wear a helmet while riding. Please never operate your motorcycle while under the influence of alcohol and/or drugs. Enjoy the new look of your motorcycle and please ride safely.**

9. Feed the Fi2000 black wire under the frame cross member and attach it to the **NEGATIVE** post of the battery. Velcro the module onto the flat area of the frame in the open area, in a position where it will sit flat, see Figure 2.
10. Before re-installing the fuel tank, seat and air cleaner assembly, verify your connections. Remove the door from the Fi2000 box to expose the LED's. Verify the wire connections by (1) turning the ignition on, prior to starting, and see if all three LED's are on steady. If you have no light, your ground connection (BLACK wire) has not made proper contact or your front injector connection is not complete. (2) After achieving a steady light from all three LED's, start the motorcycle, wait 15 seconds and let it idle, the green light should now be the only LED on. If all three LED's are still on after start up, verify you have attached the injector connectors correctly. Reattach the door when finished. **Note:** Make sure the ignition is turned off before changing any connection.
11. Re-install the seat, air cleaner assembly and fuel tank mounting bolt.

ADVANCED TUNING

The Fi2000CL-ARB works differently than previous Fi2000 products in that it uses the existing oxygen sensors that the motorcycle comes equipped with to monitor the air fuel ratio at all times and simply adds the proper amount of fuel in the acceleration and high load areas of operation (compared with the stock closed loop system from these motorcycles does not), to prevent harmful lean fuel conditions and maintain stock emissions quantities. With the utilization of the stock oxygen sensor monitoring system in combination with the Fi2000CL-ARB, the brand or style of exhaust systems and / or high flow air filter does not affect proper air-fuel ratio resulting in consistent emissions content. For example, a greater leanness created by better air volume flowing products will be fuel compensated to maintain proper air-fuel ratio than a lower air volume flowing combination of products.

In the standard cruise mode or closed loop operational mode, the motorcycle will dispense fuel and maintain the proper air-fuel ratio just as it was designed from the original equipment manufacture, because in this range of operation, the stock fuel management system will adjust the air-fuel ratio for optimized emissions content. For this reason, be sure that the motorcycle has all of the latest factory engine control management software updates and warranty approvals.

TROUBLE SHOOTING

If you have any problems refer to Step 10 in the main body of the instructions.

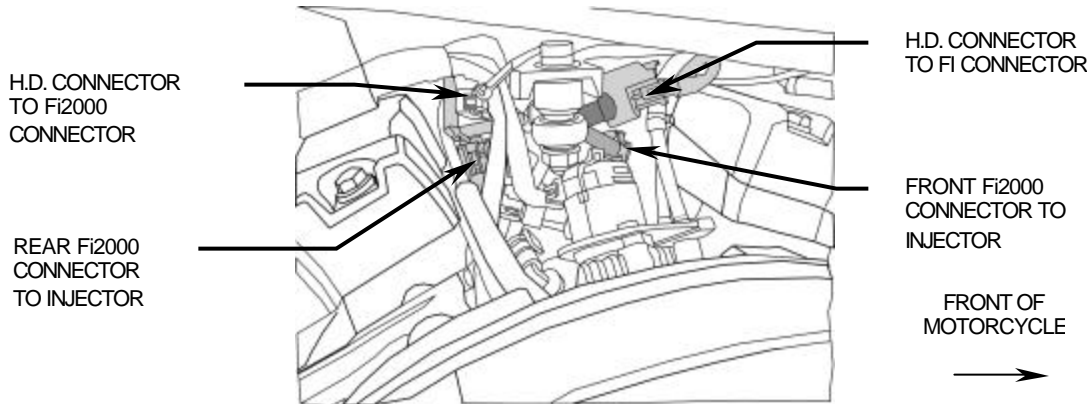

FIGURE 1

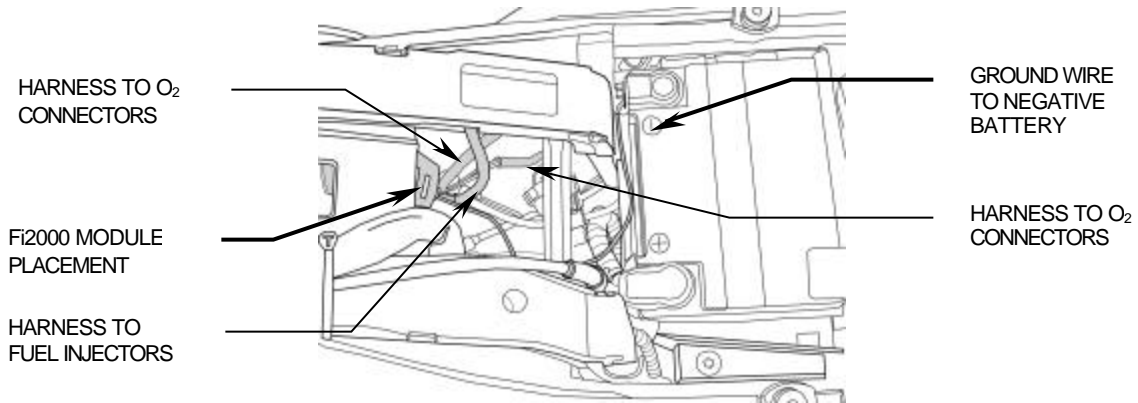

FIGURE 2

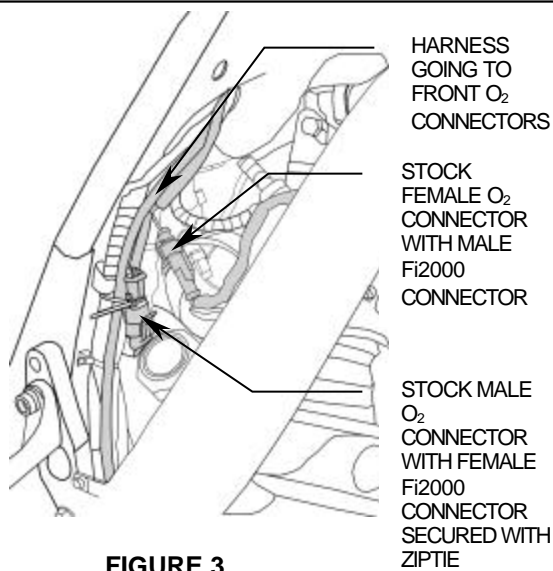

FIGURE 3

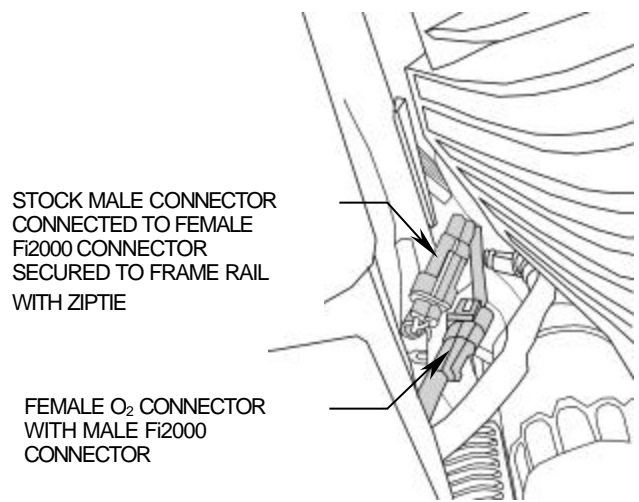

FIGURE 4