

Items Supplied >

- 1 – Powrpro Black Fuel Injection Module
- 6 – Zip Ties 6"
- 1 – Velcro Strip

Application(s) >

HARLEY DRESSER 2007

Instruction Manual >

692-1608B

Page 1 of 3

ATTENTION: All 2007 Harley DRESSER models manufactured before NOVEMBER 1, 2006 require an ENGINE CONTROL MODULE CALIBRATION update from a Harley Davidson Dealer; please reference Harley Davidson SERVICE BULLETIN M-1186. This Fi2000 is meant to function on all 2007 DRESSER models with this update and all 2007 DRESSER models manufactured after this date which should already have this update installed, check with your local dealer for verification. Read all instructions carefully and completely before installing your new POWRPRO module. It is recommended that a qualified mechanic or technician install this product.

1. Remove the seat and air cleaner assembly. Remove rear mounting bolt from fuel tank and prop the fuel tank as high as it will comfortably go.
2. Locate the factory connector on each fuel injector. Depress the tab on the connector and pull the connector free from the injector and move it out of the way. **Note:** A pair of needle nose pliers and a long flat blade screwdriver helps with this job, see Figure 1.
3. Lay the Fi2000 module in the open area just behind the fuel tank, Figure 2. By carefully prying the 3 locking tabs, open the right side of the black plastic runner that houses the stock wiring harnesses. Slip the Fi2000 harness into the runner; use the cutout on the left side towards the rear of the runner to feed the harness into it. Route the harness forward about 6 inches and then have it exit at the right side of the runner. Snap the top of the plastic runner back into place.
4. Route the Fi2000 module's injector plugs behind the existing wires and under the upper motor mount assembly. Connect one pair of the Fi2000 injector plugs onto the front injector and insert the black connector into the original Harley connector, see Figure 1.
5. Attach the Fi2000 module's remaining injector plug onto the rear injector. Then take the original female HD connector and insert the corresponding male Fi2000 connector, refer to Figure 1. Tuck both front and rear injector connections out of the way.
6. It is now time to install the oxygen sensor harnesses. In the open area where the Fi2000 module has been placed you will see a round hole (approximately 1" in diameter), in the lower area of the frame. Feed the two O₂ sensor harnesses through this hole. Above the transmission on the right side locate the stock rear O₂ sensor connection. Unplug this and plug the corresponding Fi2000 connectors from the shorter Fi2000 O₂ sensor harness into these connectors see Figure 3.
7. Route the longer O₂ harness through the factory loop holding the rear brake hose then up the right side of the bottom frame rail and ziptie it in 3 locations.

DISCLAIMER: NOT LEGAL FOR SALE OR USE IN CALIFORNIA ON ANY POLLUTION CONTROLLED MOTOR VEHICLES.

8. Route the harness behind the rear brake assembly and then up the front right frame downtube so the connectors end up at the cross member where the front O₂ connection is located. Ziptie the Fi2000 harness to the right downtube. Cut the 2 zipties holding the factory connection, unplug the connection, and then plug in the corresponding Fi2000 connectors into the factory connectors. Re-ziptie both connections along the frame cross member, using the original ziptie holes, Figure 4.
9. Feed the Fi2000 black wire under the frame cross member and attach it to the **NEGATIVE** post of the battery. Velcro the module onto the flat area of the frame in the open area, in a position where it will sit flat, see Figure 2.
10. Verify that the module has power and connections have been made correctly; watch the clear window on the FI housing and turn "ON" the key ignition and set the handlebar run switch to "ON", confirm that the Red LED turns on. On some models the Red light will turn off after 4-5 seconds as the fuel pump cycles off, which is OK. If you do not see a Red light, it may be necessary to wait for the alarm to reset (if applicable) and try again. Also confirm the side stand is up, bike is in neutral, and clutch is in. Start the bike and confirm the LED remains on solid Red. **NOTE:** Make sure ignition is turned off before attempting to change any Fi2000 harness connections if no Red light is seen. For access to the Blue Tooth Tuning App on the module, please download the PowrPro Black App to your smart device, Android 4.3 & later or Apple iOS 5.0 & later operating systems. Once the app is installed, make sure the motorcycle is in neutral and start the engine, use the connect button within the app and the Blue light on the Fi module window will light up during pairing connection and remain solid Blue while paired and connected with respective Android or Apple Device. Once the app has been used and settings saved and disconnected through the app, the Blue light will turn off, and the PowrPro Black will be ready for continued service on the motorcycle.
11. Re-install the seat, air cleaner assembly and fuel tank mounting bolt.

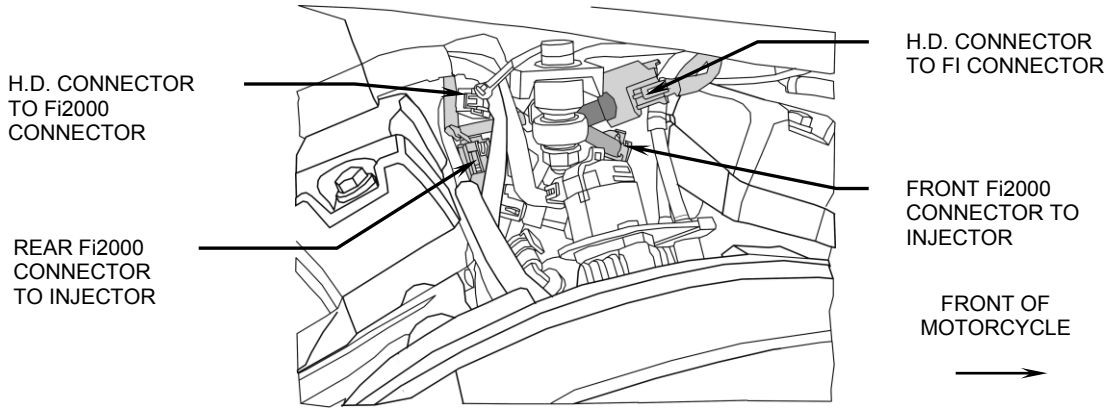

FIGURE 1

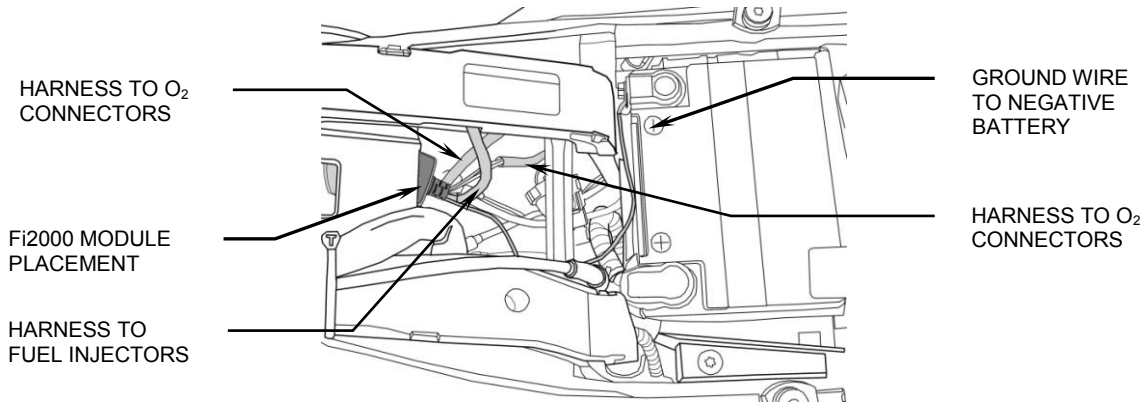

FIGURE 2

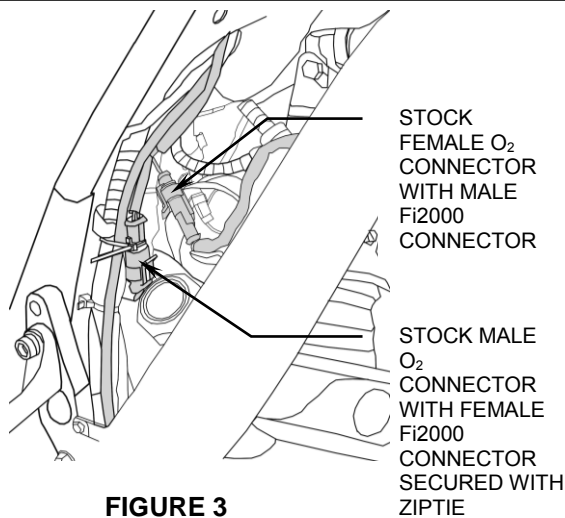

FIGURE 3

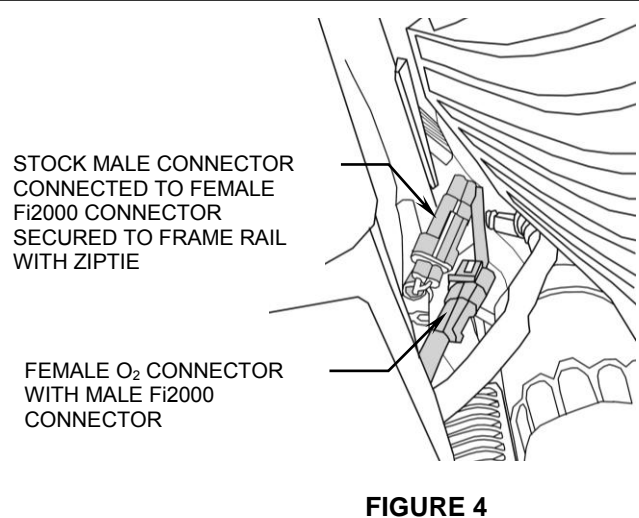

FIGURE 4

DISCLAIMER: NOT LEGAL FOR SALE OR USE IN CALIFORNIA ON ANY POLLUTION CONTROLLED MOTOR VEHICLES.