

Items Supplied >

- 1 – Fi2000R Fuel Injection Module
- 2 – Zip Ties
- 1 – Velcro Strip
- 2 – Oxygen Sensor Eliminators

Application(s) >

- HARLEY DYNA '06 – '10 with O₂ Sensor
Disconnected
- SOFTAIL '07 – '10 with O₂ Sensor
Disconnected

Instruction Manual >

692-1606

Page 1 of 7

ATTENTION: All 2007 Harley DYNA and SOFTAIL models manufactured before NOVEMBER 1, 2006 require an ENGINE CONTROL MODULE CALIBRATION update from a Harley Davidson Dealer; please reference Harley Davidson SERVICE BULLETIN M-1186. This Fi2000R is meant to function on all 2007 DYNA and SOFTAIL models with this update and all 2007 – 2010 DYNA and SOFTAIL models manufactured after this date which should already have this update installed, check with your local dealer for verification. 2006 models that this Fi2000 module is intended for will need to have the base pot settings adjusted for accurate operation refer to Step 10 under '06 DYNA installation.

Read all instructions carefully and completely before installing your new Fi2000R module. It is recommended that a qualified mechanic or technician install this product.

'06 & '07 – '10 DYNA INSTALLATION INSTRUCTIONS

1. Remove the seat and air cleaner assembly, remove both front and rear gas tank mounting bolts. Prop the rear of the gas tank up approximately 2".
2. Locate the factory connector on each fuel injector. Depress the clip on the connector and pull the connector free and move it out of the way. **Note:** A pair of needle nose pliers and a long flat blade screwdriver helps with this job. If you need additional access to the fuel injector connectors, you can remove the Idle Air solenoid by removing the two 5/16" bolts holding it on and loosening the Torx #20 screw on throttle cable bracket. Make sure to use blue thread-locking compound when refitting the two 5/16" bolts and correctly position the o-ring when reattaching.
3. Lay the Fi2000R module in the area underneath the seat, do not attach it to the motorcycle, route the wire harness forward up the left side of the frame and across to the right side just ahead of the rear cylinder head, See Figure 1. Route the forward set of connectors under the upper motor mount.
4. Attach the Fi2000R module's forward injector plug, with the grey and red wires to the front injector. Take the original female H.D. connector and insert the corresponding Fi2000R male connector, with the brown and red wires, into it, refer to Figure 2.
5. Attach the Fi2000R module's rear female injector plug, with the blue and red wires, onto the rear injector. Then take the original female HD connector and insert the corresponding male Fi2000R connector, with the green and red wires, into it, refer to Figure 2.
6. Remove the right hand battery cover, route the black ground wire from the Fi2000R through the gap just under the frame and to the rear of the battery box. Attach the ring terminal to the negative post of the battery. Now cut the factory zip-tie holding the rear fender wire harness to the ECU bracket and pull that harness up and out of the way, see Figure 1.

* *Cobra® recommends you always wear a helmet while riding. Please never operate your motorcycle while under the influence of alcohol and/or drugs. Enjoy the new look of your motorcycle and please ride safely.*

'06 & '07 – '10 DYNA INSTALLATION INSTRUCTIONS CONTINUED:

7. It is now time to install the oxygen sensor eliminator modules. This product is designed to eliminate the “check engine” light from coming on when the stock oxygen sensors are disconnected on 2006 - 2009 Harley Davidson Motorcycles utilizing fuel injection. The motorcycle has a full “open loop” fuel injection map written in its ECU and the motorcycle reverts to this default map after the oxygen sensors have been removed and disconnected.
8. Locate the black waterproof connector in the wire harness bundle that is tucked down into the open area under the seat. Unplug the connector that comes from the rear oxygen sensor, and replace that end with one of the oxygen sensor eliminators.
9. Remove the two bolts holding the voltage regulator onto the lower front frame. Let it drop down, then directly behind that is a black plastic panel that has a locking tab at the top. Hinge that panel down to access the plugs behind it. Locate the front oxygen sensor connection, slide it off its holding pin and unplug the connector. Replace the sensor wire end with our eliminator, and then replace the connection onto its holding pin. Reinstall the panel and the voltage regulator.
10. Before re-installing the seat and air cleaner assembly, verify your connections. **NOTE:** The Fi2000R pot settings come preset from the factory for the 2007 - 2009 DYNA and SOFTAIL, (Figure 7), for owners, with a 2006 DYNA please adjust the Fi2000R to the base pot settings shown in (Figure 8), prior to proceeding further. Remove the door from the Fi2000 box to expose the LED's. Verify the wire connections by (1) turning the ignition on, prior to starting, and see if all three LED's are on steady. If you have no light, your ground connection (BLACK wire) has not made proper contact or your front injector connection is not complete. (2) After achieving a steady light from all three LED's, start the motorcycle, wait 15 seconds and let it idle, the green light should now be the only LED on. If all three LED's are still on after start up, verify you have attached the injector connectors correctly. Reattach the door when finished. **Note:** Make sure the ignition is turned off before changing any connection.
11. Remove the backing from the Velcro and attach the Velcro pad down between the back of the battery and the ECU on the flat area of the frame. Apply the mating Velcro to the back of the Fi2000R and attach, see Figure 1. Replace the rear fender wire harness above the Fi2000R.
12. Re-install the seat and air cleaner assembly.

'07 – '10 SOFTAIL INSTALLATION INSTRUCTIONS:

1. Remove the seat and the air cleaner assembly. Remove the rear fuel tank bolt and prop the rear of the fuel tank up as far as it will comfortably go.
2. Locate the factory fuel injector connectors and by depressing the tab release the connectors from the injectors, see Figure 1.
3. Lay the Fi2000 module in the area underneath the seat, feed the harness forward, pushing it under the right side of the factory harness hold down bracket, see Figure 2. Now feed the Fi2000 harness into the factory black plastic sleeve over the rear cylinder head, make sure the harness rest into the bottom of the sleeve to allow proper slack so the connectors reach the injectors.
4. Route the front set of Fi2000 connectors (red and brown wires) behind the existing wires and connect the gray connector onto the injector. Now insert the black connector into the original Harley connector. Repeat for the rear injector (red and green wires). Tuck the new set of connectors out of the way.
5. It is now time to install the oxygen sensor eliminator modules. This product is designed to eliminate the “check engine” light from coming on when the stock oxygen sensors are disconnected on 2006 - 2009 Harley Davidson Motorcycles utilizing fuel injection. The motorcycle has a full “open loop” fuel injection map written in its ECU and the motorcycle reverts to this default map after the oxygen sensors have been removed and disconnected.
6. At the front of the bike, remove the 2 allen head bolts that hold the voltage regulator mounting bracket to the block, and remove the rectangular cover over the top of this bracket. Ease the voltage regulator bracket forward just enough to access the front oxygen sensor connection, (this may have already been done if the exhaust is being changed). Plug one of the supplied O₂ eliminators into the connector on the harness then position it back into its original position, see Figure 5. Reinstall the voltage regulator and top cover. Zip tie the O₂ sensor wire to the frame rail if leaving it in place.

'07 – '10 SOFTAIL INSTALLATION INSTRUCTIONS CONTINUED:

7. The rear O₂ connector is under the oil tank on the right side of the bike. We recommend that you temporarily remove the battery to gain access to this connector, but you may attempt to install the O₂ eliminator from underneath, see Figure 6. If leaving the O₂ sensor in place zip tie its harness to the starter wire harness to prevent it from melting on the case.
8. If the battery has been removed reinstall it. Attach the black wire to the NEGATIVE post of the battery. Attach the Fi2000 Module with Velcro as shown in Figure 4.
9. Before re-installing the seat and air cleaner assembly, verify your connections. **NOTE:** The Fi2000R pot settings come preset from the factory for the 2007 - 2009 DYNA and SOFTAIL, Figure 7, for owners, with a 2006 DYNA please adjust the Fi2000R to the base pot settings shown in Figure 8, and refer to the previous instructions set. Remove the door from the Fi2000 box to expose the LED's. Verify the wire connections by (1) turning the ignition on, prior to starting, and see if all three LED's are on steady. If you have no light, your ground connection (BLACK wire) has not made proper contact or your front injector connection is not complete. (2) After achieving a steady light from all three LED's, start the motorcycle, wait 15 seconds and let it idle, the green light should now be the only LED on. If all three LED's are still on after start up, verify you have attached the injector connectors correctly. Reattach the door when finished. **Note:** Make sure the ignition is turned off before changing any connection.
10. Re-install the seat and air cleaner assembly.

ADVANCED TUNING

Your Cobra® Fi2000 fuel injection module has been tested and preset for best function and ride-ability on a motorcycle with aftermarket aircleaner, Cobra exhaust, and no download, (ECU Flash.) The Fi2000 does however, have 3 important adjustments that allow you to tune the module for optimum performance, especially if you have performed other changes to your motorcycle. These adjustments also allow you to resolve drivability issues if our stock settings are not exactly right for your bike. Make sure your motorcycle is up to normal operating temperature (15 minutes of riding should be sufficient) before making any adjustments. Remove the door to expose the pots shown in Figure 7 for 2007 - 2009 DYNA and 2007 - 2009 SOFTAIL models and Figure 8 for 2006 DYNA models.

GREEN LED POT (left pot) - this adjustment affects idle and cruise fuel. If you have cruising issues, this is where you would try a different setting. Generally, surging and uneven running while cruising is a lean fuel condition, so try adding a small increase in fuel by turning the adjustment clockwise with a small flat blade screwdriver a 1/2 of a position. Test-drive the bike to feel an improvement and only increase the setting until the surge goes away. Also, backfiring or popping on trailing throttle is generally a lean symptom (or an exhaust gasket leak). Try the same small increases as above just until the backfiring goes away.

YELLOW LED POT (middle pot) - this adjustment affects acceleration and power fuel. If you have a hesitation or bogging on acceleration, this is where you would try a different setting. Aftermarket air cleaner assemblies generally lean out fuel mixtures, so try small clockwise increases as above until a smooth acceleration returns.

RED LED POT (right pot) - this adjustment is the top end or power fuel adjustment. Just like the main jet in a carburetor, it starts to control fuel, as you demand maximum power from your bike and takes over completely above 4000 R.P.M. As performance gains are added to your motorcycle, such as big bore kits, camshafts, flowed cylinder heads, etc., each component will increase the fuel demand of the system. With the red pot turned to its maximum (10) position, the Fi2000 will cope with nearly 100 R.W. horsepower. An all-stock motor will only require a 2 position. You can generally, if you are using quality performance engine upgrades, in a sensible combination equate the numbers evenly from 2 up to 10 based on horsepower gains.

TUNING NOTES

Typically 2 into 1 or our speedster exhaust system require one additional position, on the yellow and red pots, over slip-ons or staggered duals.

On high performance motors, slip-on mufflers do not flow well enough and create fuel setting problems and detonation. Cobra recommends the installation of any of its complete exhaust systems.

TROUBLE SHOOTING

If you have any problems refer to step 9 in the main body of the instructions.

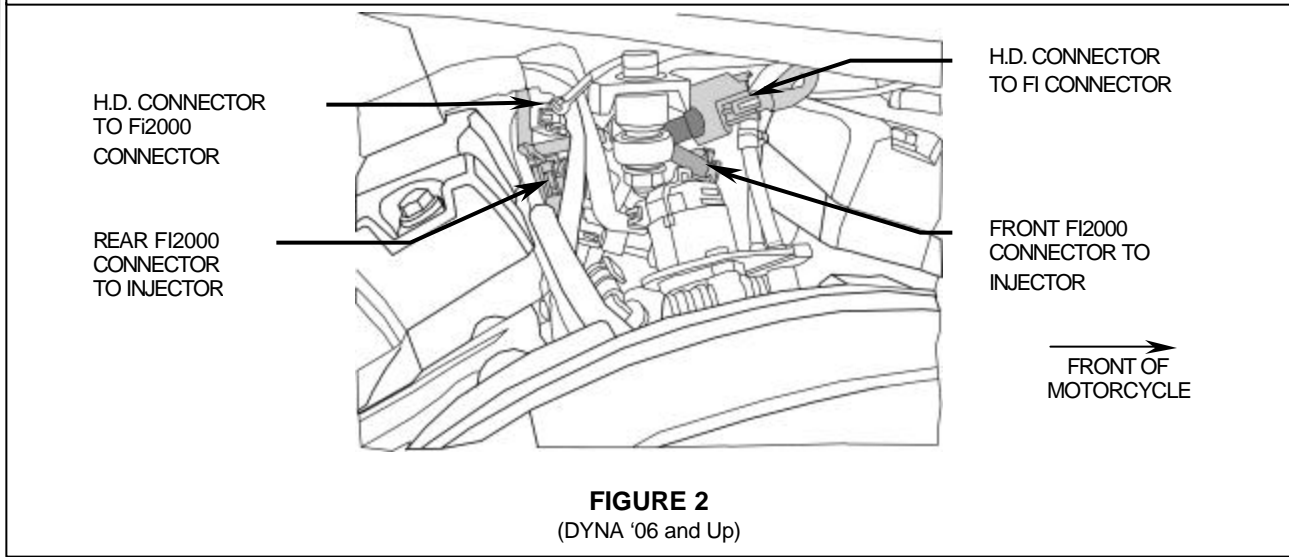
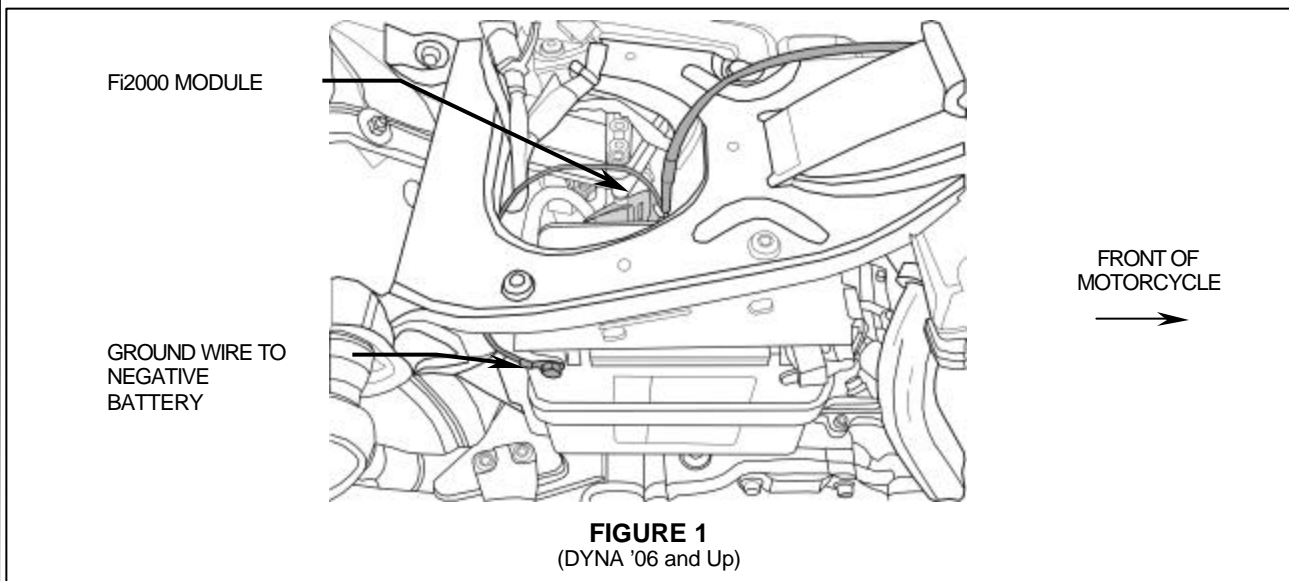

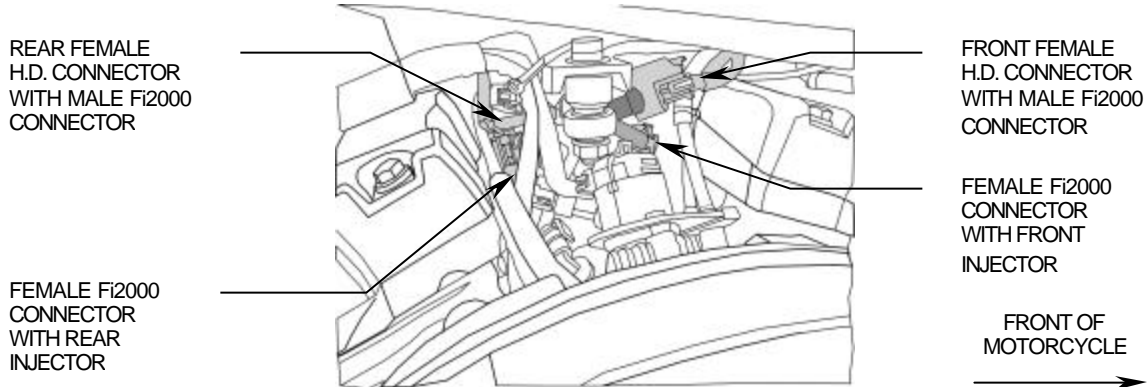

FIGURE 3
(‘07 - ‘10 SOFTAIL)

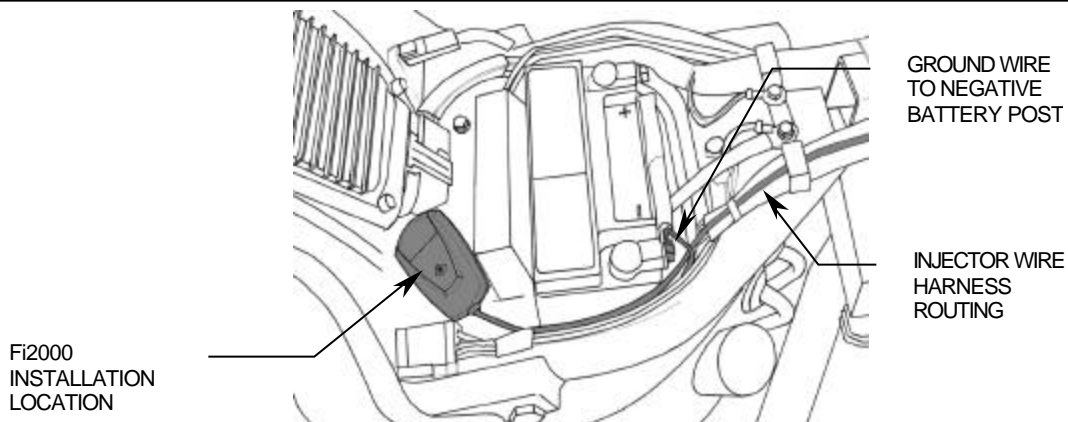

FIGURE 4
(‘07 - ‘10 SOFTAIL)

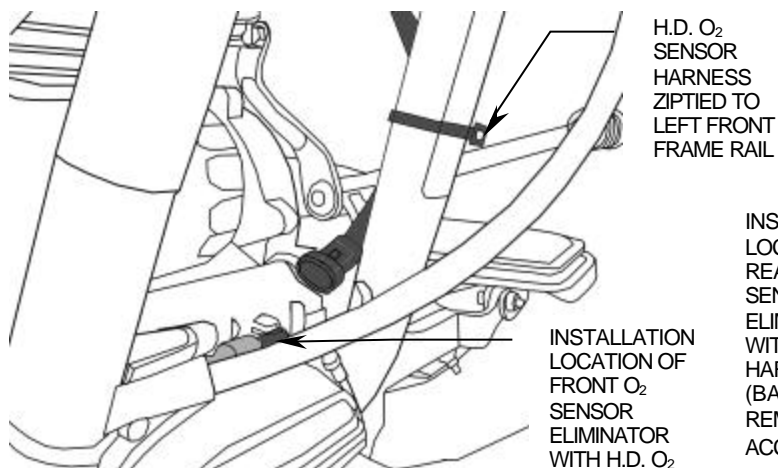

FIGURE 5
(‘07 - ‘10 SOFTAIL)

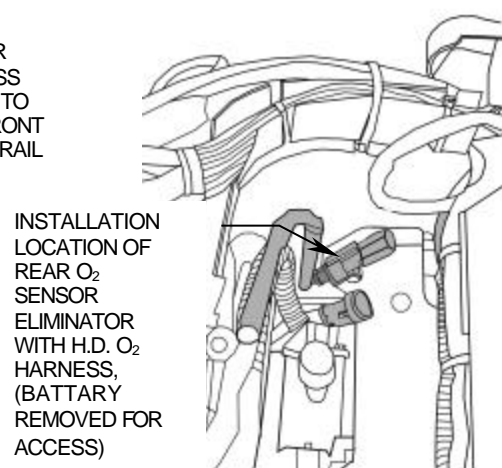

FIGURE 6
(‘07 - ‘10 SOFTAIL)

FIGURE 7 ('07 – '10 DYNA & '07 – '10 SOFTAIL)

Fi2000 Default pot setting

Aftermarket Air Cleaner, Exhaust
Download: From Bulletin: M-1186

Default Pot Settings:

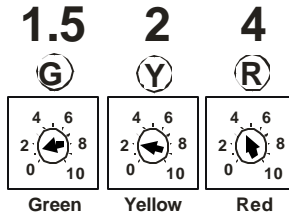

Aftermarket Exhaust Only
Download: From Bulletin: M-1186

Default Pot Settings:

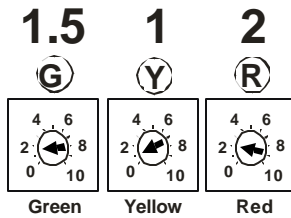

All Stock
Download: From Bulletin: M-1186

Default Pot Settings:

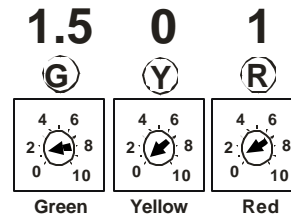
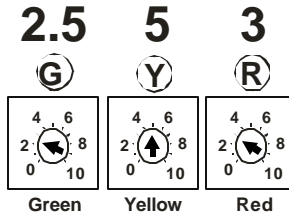

FIGURE 8 ('06 DYNA)

Fi2000 Default pot setting

Aftermarket Air Cleaner, Exhaust No Downloads

Default Pot Settings:



All Stock

No Downloads *

Default Pot Settings:

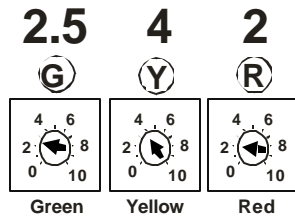

Aftermarket Air Cleaner, Exhaust

With #1 Download *

Default Pot Settings:

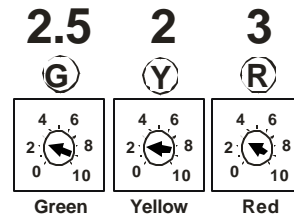

Stage 2 Motor 103cu. In., Cam, Exhaust No Download *

Default Pot Settings:

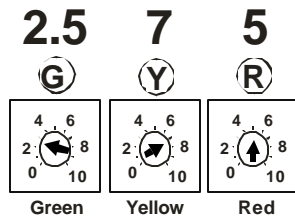

Stage 2 Motor 103cu. In., Cam, Exhaust With #2 Download *

Default Pot Settings:

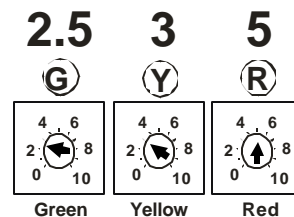

* If you have installed a Screamin Eagle air cleaner system the pot settings will need to be set 1 position lower than shown. (Example: The green pot will need to be set at 1.5 instead of 2.5, etc...) You can identify the Screamin Eagle air cleaner by the blue rubber rings.