

## Items Supplied >

- 1 - FRONT HEADPIPE W/ HEATSHIELD
- 1 - REAR HEADPIPE W/ HEATSHIELD
- 1 - MUFFLER ASSEMBLY
- 1 - BIKINI HEATSHIELD
- 1 - BRACKET, EXHAUST MOUNT
- 4 - CLAMP, HS-24 (SMALL)
- 1 - CLAMP, HS-28 (LARGE)
- 2 - CLAMP, 27-61MSC
- 2 - BOLT, 5/16" X 1/2" FLANGE W/ LOCK PATCH
- 1 - SPACER, .750"O.D. X .343" I.D. X .550"L BLACK
- 2 - SPACER, ALUMINUM .550"O.D. X .344" I.D. X .170"L

## Application(s) >

- |            |       |
|------------|-------|
| HARLEY:    |       |
| DYNA       | 12-17 |
| SWITCHBACK | 12-16 |

## Instruction Manual >

6468

Page 1 of 3

**PRIOR TO INSTALLATION, MAKE SURE YOUR STOCK HEAD PIPE GASKETS ARE IN GOOD CONDITION. IF YOU HAVE ANY DOUBTS AS TO THEIR CONDITION, REPLACE THEM.**

**Read all instructions carefully and completely before installing your new exhaust system!**

1. Apply masking tape to any surrounding parts to protect them from getting scratched.
2. For Switchback models, the right side floorboard will need to be removed from the mounts. Also remove the forward mount bolt and loosen the rearward mount bolt so the mount will swing out of the way for clearance.
3. Unplug O<sub>2</sub> sensors on front and rear headpipes from motorcycle wire harnesses.
4. Remove the stock exhaust system being careful not to damage the headpipe gaskets. If the headpipe gaskets are in good condition they do not need to be removed from the cylinders. Remove and save the flanges, nuts, retaining rings and O<sub>2</sub> sensors from the stock exhaust.
5. Remove the stock exhaust mount bracket.
6. Install the supplied exhaust mount bracket using the stock bolts. See **FIGURE 1**. Tighten the bolts to factory specifications. If applicable, be sure to insert the large spacer between the exhaust mount and the transmission case as shown in **FIGURE 1**. For Switchback models, also insert 2 of the supplied small aluminum spacers into the large holes in the exhaust mount bracket as shown in **FIGURE 2**.

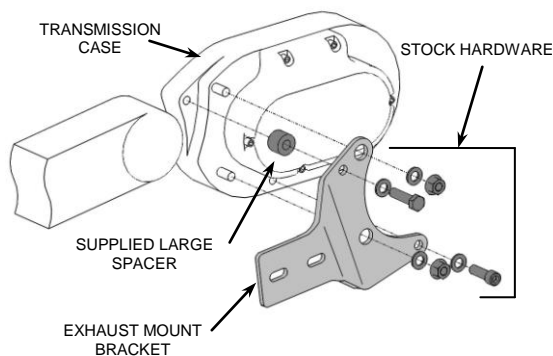

**FIGURE 1**  
**DYNA**

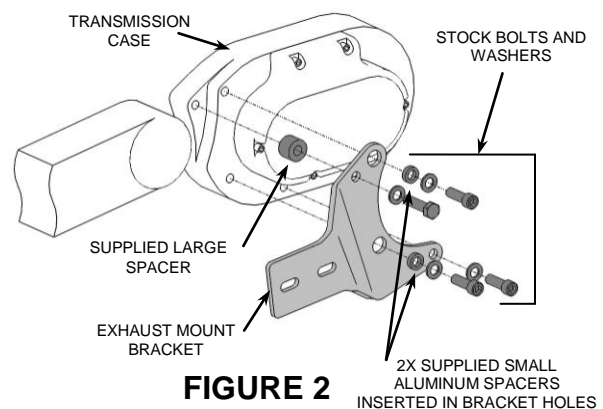
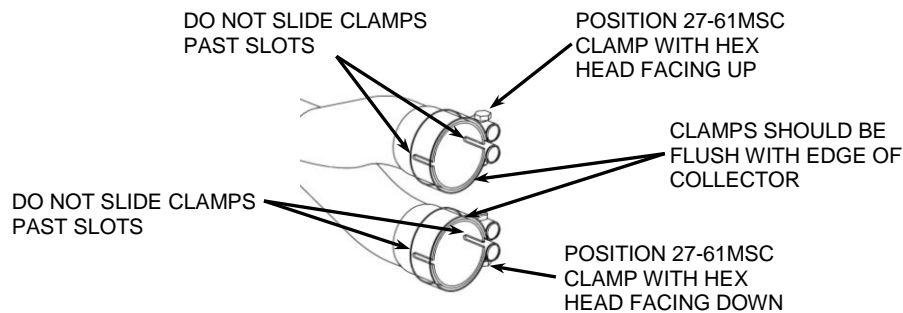

**FIGURE 2**  
**SWITCHBACK**

Continued on Page 2

**DISCLAIMER: NOT LEGAL FOR SALE OR USE IN CALIFORNIA ON ANY POLLUTION CONTROLLED MOTOR VEHICLES.**

7. Install the stock flanges, retaining rings and O<sub>2</sub> sensors onto the supplied front and rear headpipes.
8. Install the front headpipe (with stock gasket in place) onto the front cylinder using the stock nuts but **DO NOT TIGHTEN** at this time.
9. Position the supplied #27-61 MSC muffler clamps with hex head facing the direction shown in **FIGURE 3** over the inlets of the muffler.
10. Insert the rear headpipe into the top inlet tube of the muffler. Make sure to slide it in as far as possible.
11. Install the rear headpipe and muffler assembly (with stock gasket in place) onto the rear cylinder and slide the lower muffler inlet on to the front headpipe. Rotate the rear headpipe as needed to align it with the cylinder outlet. Use the stock nuts to fasten the rear headpipe to the cylinder but **DO NOT TIGHTEN** at this time. Make sure the front and rear headpipes are pushed in as far as possible into the inlets of the muffler.
12. Secure the muffler assembly to the exhaust mount bracket using the (2) supplied 5/16"-18 bolts but **DO NOT TIGHTEN**.
13. Make sure the muffler assembly, front headpipe, and rear headpipe are straight and parallel and tighten in the following order; headpipe flanges to the cylinders (slowly tightening opposing nuts), muffler assembly to the exhaust mount and finally the muffler clamps. (NOTE: The muffler clamps should be flush with the end of the muffler inlets when tightened. See **FIGURE 3**. If the muffler clamps are slid past the slots on the muffler inlets the clamps will not tighten properly).



**FIGURE 3**

14. Plug the O<sub>2</sub> sensors back into motorcycle wire harnesses.
15. Unscrew the small **HS-24** clamps and feed the tail end of the clamp through the clips on the inside of the heatshields. See **FIGURE 4** for proper positioning of the clamps on the heatshields. (NOTE: The arrows point to the positioning of the hex head of the clamps. The hex head of the clamps should be accessible for tightening but not visible when the heatshields are mounted to the pipes.)
16. Unscrew the larger **HS-28** clamp and insert the tail end through the clip on the inside of the bikini heatshield. See **FIGURE 4** for proper positioning of the clamps on the heatshields. (NOTE: The arrows point to the positioning of the hex head of the clamps.)
17. Install the front heatshield first. (NOTE: Spread the hose clamps apart slightly to make it easier to slide them over the muffler assembly and headpipes.) Adjust the heatshield as far back as possible on the headpipe so that it will align properly with the bikini heatshield. Make sure the clamp on the muffler inlet does not interfere with the heatshield and is aligned as shown in **FIGURE 3**. Snug the heatshield clamps but do not tighten.
18. Install the rear heatshield the same way as the front heat shield. See **FIGURE 4**.

Continued on Page 3

**NOTE:** Arrows point to the position of the hex head of the clamps.



HS-28  
CLAMP

**FIGURE 3**

HS-24  
CLAMP

HS-24  
CLAMP

HS-24  
CLAMP

HS-24  
CLAMP

19. Install the bikini heatshield over the collector area. Adjust the front and rear heatshields fore and aft on the headpipes so that they go underneath the bikini heatshield. **NOTE:** If the headpipes are not inserted far enough into the muffler inlets the heatshields will not be able to go underneath the bikini heatshield.
20. When the heatshields are aligned properly, tighten the clamps on the front and rear heatshields first. Then tighten the bikini heatshield clamp last.
21. For Switchback models, install the right floorboard mount and floorboard. Tighten all fasteners to manufacture's specification.
22. Make sure all the hardware (brackets, head pipes, heatshields, and floorboards) has been tightened appropriately.
23. **IMPORTANT: Before starting your engine remove all fingerprints from chrome with a quality wax or chrome polish. Failure to do so can cause chrome discoloration. Due to fluctuations in fuel delivery settings, timing, etc., Cobra Engineering does not warrant against chrome discoloration.**

**IMPORTANT:** It is recommended that a Cobra Fi2000® Closed Loop Digital Fuel Processor (**Cobra Part #692-1616AT, 692-1616CL, or 692-1616CL-50 for California models**) be installed with the Cobra exhaust system.

**DISCLAIMER:** NOT LEGAL FOR SALE OR USE IN CALIFORNIA ON ANY POLLUTION CONTROLLED MOTOR VEHICLES.