

Items Supplied >

- 1 – FRONT HEADPIPE AND HEATSHIELD
- 1 – REAR HEADPIPE AND HEATSHIELD
- 1 – CROSSOVER PIPE ASSEMBLY AND HEATSHIELD
- 1 – BRACKET, FRONT HEADPIPE SUPPORT
- 1 – BRACKET, CROSSOVER PIPE SUPPORT
- 1 – FLOORBOARD MOUNT SPACER PLATE
- 1 – CLAMP, FRONT HEADPIPE SUPPORT
- 11 – CLAMP, HOSE HS-24
- 2 – CLAMP, 27-61 MSC
- 1 – THICK 3/8" WASHER
- 1 – THIN 3/8" WASHER
- 1 – 3/8" X 1" CARRIAGE BOLT
- 1 – 3/8" NYLOCK NUT

Application(s) >

HARLEY:	
TRI GLIDE	10-16
FREEWHEELER	15-16

Instruction Manual >

6254

Page 1 of 5

PRIOR TO INSTALLATION, MAKE SURE YOUR STOCK HEADPIPE GASKETS ARE IN GOOD CONDITION. IF YOU HAVE ANY DOUBTS AS TO THEIR CONDITION, REPLACE THEM.

Read all instructions carefully and completely before installing your new exhaust system!

1. Remove the saddle bags, right side cover, and right front floorboard from the frame.
2. Unplug the O₂ sensors on the front and rear headpipes from the motorcycle wire harness.
3. Remove the stock exhaust system being careful not to damage the headpipe gaskets. If the headpipe gaskets are in good condition they do not need to be removed from the cylinders. Remove and save the flanges, nuts, retaining rings and O₂ sensors from the stock exhaust. Label the O₂ sensors front and rear to ensure they will be installed on the proper headpipe.
4. Remove the stock exhaust mount bracket.
5. Install the supplied headpipe support bracket using the stock bolts. See **FIGURE 1**. Tighten the bolts to factory specifications.

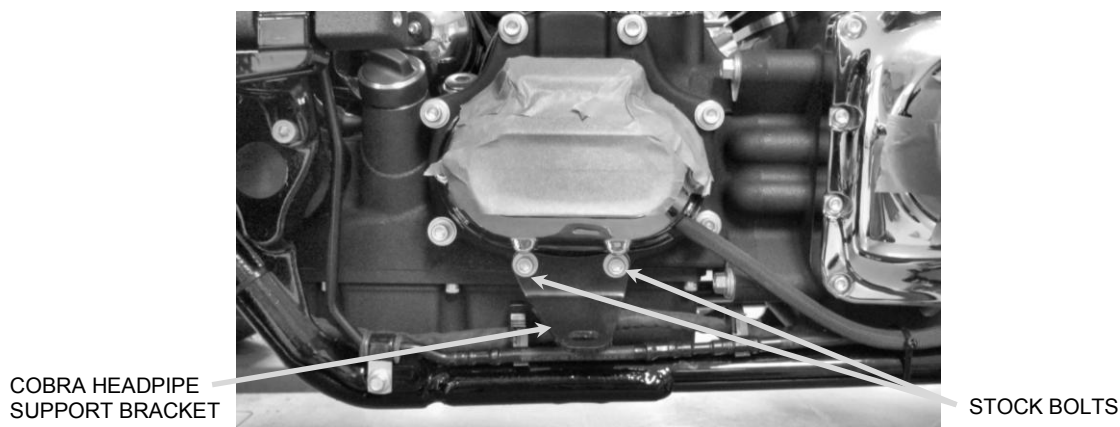
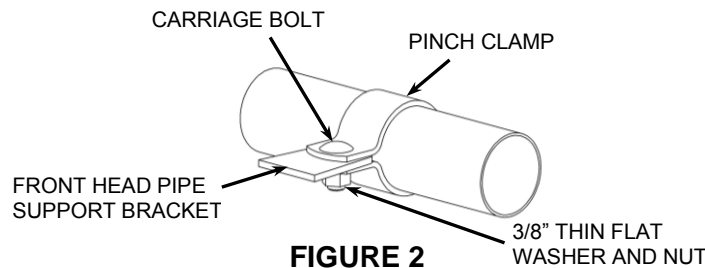

FIGURE 1

Continued on Page 2

DISCLAIMER: NOT LEGAL FOR SALE OR USE IN CALIFORNIA ON ANY POLLUTION CONTROLLED MOTOR VEHICLES.

6. Install the stock flanges, retaining rings and O₂ sensors onto the supplied front and rear headpipes. Be sure to install the front O₂ sensor on the front headpipe and the rear O₂ sensor on the rear headpipe.
7. Install the front headpipe (with stock gasket in place) onto the front cylinder using the stock nuts. Snug the nuts but **DO NOT TIGHTEN** at this time.
8. Slide the supplied pinch clamp over the front headpipe making sure the square hole on the clamp is facing up and towards the inside. Position the clamp over the support bracket so that the pinch clamp captures both sides of the bracket. See **FIGURE 2**. Insert the supplied 3/8" carriage bolt through the top of the pinch clamp and support bracket. Install the 3/8" thin flat washer and nut onto the bottom of the carriage bolt but **DO NOT TIGHTEN** at this time.

**FIGURE 2**

9. Install the rear headpipe (with stock gasket in place) onto the rear cylinder using the stock nuts. Snug the nuts but **DO NOT TIGHTEN** at this time.
10. Position 2 of the supplied #27-61 MSC muffler clamps onto the crossover assembly inlets. The hex head of the both clamps should be inward and down. See **FIGURE 3**. (NOTE: The clamps should be flush with the end of the crossover assembly inlets when tightened. See **FIGURE 3**. If the clamps are slid past the slots on the crossover assembly inlet the clamps will not tighten properly).

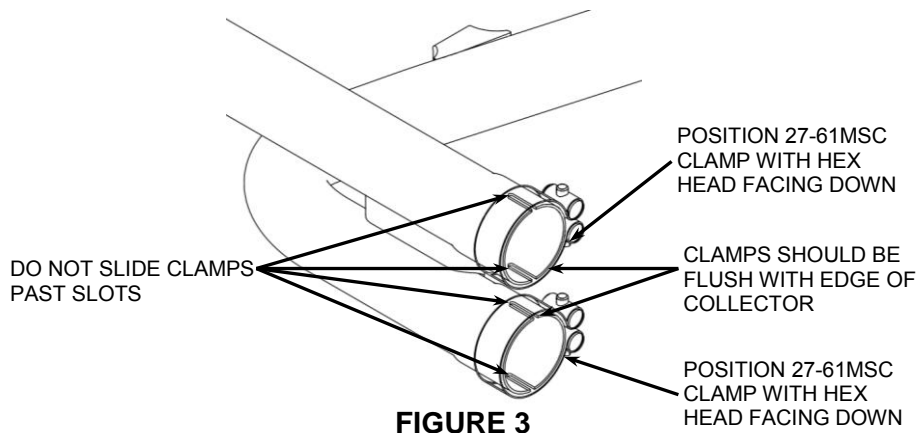
**FIGURE 3**

11. Make sure the front and rear headpipes are parallel with each other and then slide the crossover assembly onto the headpipes by tapping on the headpipes with your hand as you push the crossover assembly forward. Make sure the crossover assembly slides as far forward as possible. See **FIGURE 4**. Lightly snug the 27-61MSC clamps around the expanded inlets but **DO NOT TIGHTEN** at this time. NOTE: Make sure the rear headpipe is aligned parallel with the top tube of the crossover assembly. With the crossover assembly installed, the rear headpipe and top tube of the crossover should make a straight line.

Continued on Page 3

NOTE: Arrows point to the position of the hex head of the clamps.



27-61 MSC
CLAMP

FIGURE 4

22. Install the supplied crossover support bracket to the stock mounting location using the (2) stock allen bolts. Lightly snug the bolts but **DO NOT TIGHTEN** at this time. Adjust the crossover pipe assembly fore and aft so the mount on the crossover assembly rests flush against the support bracket. Then push up lightly on the left side of the crossover assembly to align the bracket and insert the stock 5/16 hex flange bolt. Lightly snug the bolt but **DO NOT TIGHTEN** at this time. See **FIGURE 5**. **IMPORTANT: DO NOT** force the crossover assembly into position. If a lot of force is needed to align the crossover tube and support bracket then adjust the rear headpipe and crossover assembly until it will align with only enough force to counter act the weight of the left side of the crossover assembly. Also, Make sure the crossover assembly has clearance all around and does not make contact with the transmission pan; adjust as needed while bolts are loose.

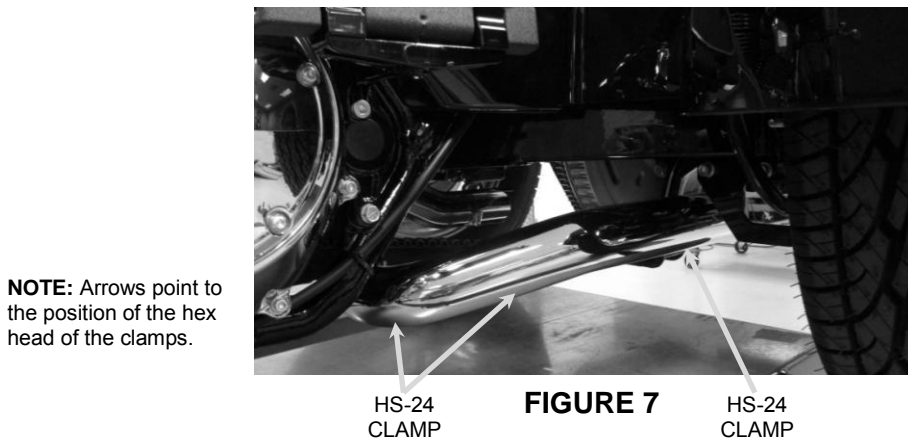
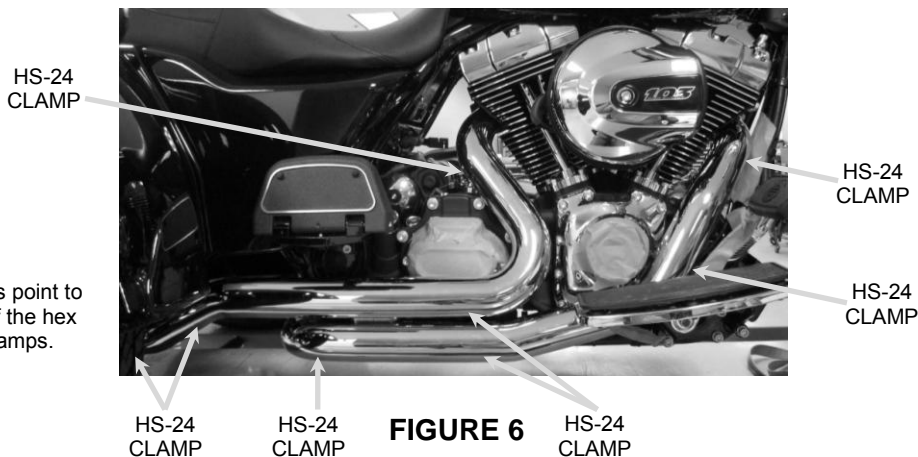

FIGURE 5

23. Reinstall the mufflers onto the crossover pipe assembly and reinsert the (2) stock 5/16-inch bolts into each rear muffler mount. **Do not tighten** clamps or bolts.
24. Make sure the headpipes, crossover assembly, and mufflers are aligned properly and tighten the (2) allen bolts on the crossover support bracket and the 5/16 hex bolt. See **FIGURE 5**.
25. Then fully tighten the flange nuts on the exhaust port studs, followed by the 3/8" carriage bolt and nut on the front headpipe support clamp. See **FIGURE 2**.
26. Next fully tighten the (2) 27-61MSC clamps on the crossover assembly. (NOTE: The clamps should be flush with the end of the crossover assembly inlets when tightened. See **FIGURE 3**. If the clamps are slid past the slots on the crossover assembly inlet the clamps will not tighten properly).

Continued on Page 4

17. Plug the O₂ sensors back into the motorcycle wire harness and route the wires away from the exhaust in the same manner as stock.
18. Remove the heatshields and hose clamps from packaging. Unscrew the hose clamps and feed the tail end of the clamps through the clips on the inside of the heatshield so the screws are accessible with a screwdriver once the heatshield is installed. See **FIGURE 6 & 7** for proper positioning of the clamps on the heatshields. (**NOTE: The arrows point to the positioning of the hex head of the clamps.** The hex head of the clamps should be accessible for tightening but not visible when the heatshields are mounted to the pipes.)
19. Install the right rear heatshield over the rear headpipe. (Hint: Spread the hose clamps apart slightly to make it easier to slide them over the headpipes.) Align the heatshield with the headpipe and snug the clamps but **DO NOT TIGHTEN** at this time. See **FIGURE 6**.
20. Install the right front heatshield over the right front headpipe. (Hint: Spread the hose clamps apart slightly to make it easier to slide them over the headpipes.) Align the heatshield with the headpipe and snug the clamps but **DO NOT TIGHTEN** at this time. See **FIGURE 6**.
21. Place left rear heatshield in position on the crossover assembly on the left side of the motorcycle. (Hint: Spread the hose clamps apart slightly to make it easier to slide them over the headpipes.) Align the heatshield with the crossover assembly and snug the clamps but **DO NOT TIGHTEN** at this time. See **FIGURE 7**.



Continued on Page 5

22. Adjust the mufflers fore and aft to align the rear of the mufflers with the rear valence. Make sure there is a small gap between the front of the mufflers and the heatshields. Once aligned, tighten the muffler mounting bolts and the clamps. (NOTE: The clamps should be flush with the end of the muffler inlet when tightened. If the clamps are slid past the slots on the muffler inlet the clamps will not tighten properly).
23. Make sure the small gap is maintained from the previous step and then tighten all hose clamps securing the heatshields.
24. Insert the supplied floorboard spacer plate between the rear floorboard mount and the frame, then align the dowel pin and reinstall the allen bolt. Tighten to factory specifications. See **FIGURE 8**.
25. Remove the allen bolt from the right front floorboard mount. Place the supplied thick washer between the front floorboard mount and the frame. Reinstall and tighten the allen bolt to factory specifications. See **FIGURE 8**.

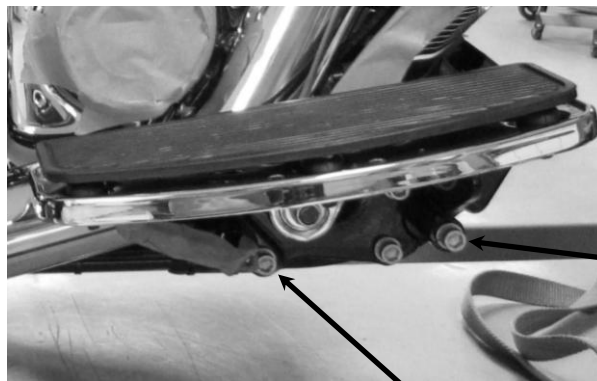

FIGURE 8

INSTALL SPACER
PLATE ON REAR
MOUNT

INSTALL THICK 3/8"
FLAT WASHER ON
FRONT MOUNT

26. Reinstall any other previously removed items. Tighten to factory specifications.
27. Make sure all the hardware (brackets, headpipes, heatshields, mufflers and floorboards) have been tightened appropriately.
28. **IMPORTANT: Before starting your engine remove all fingerprints from chrome with a quality wax or chrome polish. Failure to do so can cause chrome discoloration. Due to fluctuations in fuel delivery settings, timing, etc., Cobra Engineering does not warrant against chrome discoloration.**

IMPORTANT: If your motorcycle is equipped with fuel injection it is recommended that you install a Cobra Fi2000® Digital Fuel Processor with your Cobra exhaust system, (Cobra Part#: 692-1612CL for 2008-2009 & 692-1612CL-50 for California models 2008-2009)(Cobra Part#: 692-1615CL for 2010 & 692-1615CL-50 for California models 2010).

DISCLAIMER: NOT LEGAL FOR SALE OR USE IN CALIFORNIA ON ANY POLLUTION CONTROLLED MOTOR VEHICLES.