

# COBRA

## Items Supplied >

- 1 – FRONT MUFFLER ASSEMBLY
- 1 – REAR MUFFLER ASSEMBLY

## Application(s) >

HARLEY:	
SPORTSTER 883	14-20
SPORTSTER 1200 CUSTOM	14-20
SPORTSTER 1200 FORTY EIGHT	14-20
SPORTSTER 1200 ROADSTER	16-20

## Instruction Manual >

6081

Page 1 of 1

### Read all instructions carefully and completely before installing your new slip-on mufflers

1. Loosen all heat shield clamps for clearance but do not remove the heat shields.
2. Remove and save the mounting bolts that secure the mufflers to the tubular mounting bracket.
3. Loosen the stock muffler clamps. Remove the stock mufflers from the head pipes. Save the stock clamps because they will be reused.
4. Position the stock clamps with hex head as shown in **Figure 1** and slide them onto the slip-on mufflers.
5. **NOTE: THE MUFFLER WITH THE COBRA LOGO WILL ALWAYS BE THE REAR MUFFLER.** Slide the mufflers onto the head pipes (reverse the order of removal) until the mounting holes align.
6. Fasten the mufflers using the stock mounting bolts in the same manner as stock but **do not tighten.**
7. Check the alignment of the front and rear mufflers and make sure they are parallel. Tighten mufflers to the mounting bracket.
8. Tighten muffler clamps. (NOTE: The muffler clamps should be flush with the end of the muffler when tightened. See **Figure 2**. If the muffler clamps are slid forward past the slots on the slip collar the clamps will not tighten the mufflers properly. Also, make sure the clamp spacer is not over the slots. The slots need to be covered by the clamp band so that it seals the slots properly. Rotate the clamp if necessary).
9. Align heat shields and tighten heat shield clamps. Verify that the gap, where the mufflers meet the stock heat shields, is similar to the gap the stock mufflers allotted.
10. Tighten any remaining loose hardware to factory specifications.
11. **IMPORTANT: Before starting your engine remove all fingerprints from chrome with a quality wax or chrome polish. Failure to do so can cause chrome discoloration. Due to fluctuations in fuel delivery settings, timing, etc., Cobra Engineering does not warrant against chrome discoloration.**

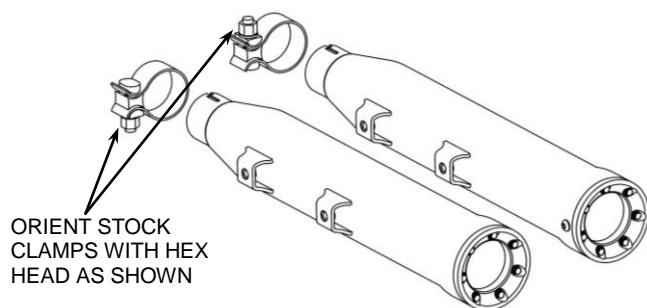

**FIGURE 1**

POSITION OF MUFFLERS AND MOUNTING BRACKETS SHOWN ABOVE MAY VARY FROM ACTUAL APPLICATION

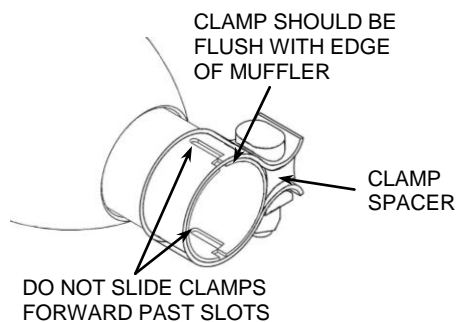

**FIGURE 2**

**IMPORTANT: To achieve optimum performance from your new mufflers it is suggested that you install a Cobra Fi2000® Digital Fuel Processor.**

**DISCLAIMER: NOT LEGAL FOR SALE OR USE IN CALIFORNIA ON ANY POLLUTION CONTROLLED MOTOR VEHICLES.**

**Anything's Possible.®**