

# COBRA

## Items Supplied >

- 1 – FRONT MUFFLER ASSEMBLY
- 1 – REAR MUFFLER ASSEMBLY

## Application(s) >

HARLEY:	
SPORTSTER 883	04-13
SPORTSTER 1200 CUSTOM	04-13
SPORTSTER 1200 LOW	06-11
SPORTSTER 1200 NIGHTSTER	07-12
SPORTSTER 1200 ROADSTER	04-08
SPORTSTER 1200 FORTY EIGHT	10-13

## Instruction Manual >

6080

Page 1 of 2

### Read all instructions carefully and completely before installing your new slip-on mufflers

1. Unbolt the head pipe support clamp from the support bracket located midway down the rear head pipe and save the hardware for reinstallation.
2. Loosen all heat shield clamps for clearance but do not remove the heat shields.
3. Loosen both head pipes at the cylinders. Remove and save the mounting bolts that secure the mufflers to the mounting bracket/crossover tube.
4. Loosen the stock muffler clamps then rotate the head pipes/mufflers out until the crossover slips disengage. Remove the stock mufflers from the head pipes. Save stock clamps because they will be reused.
5. Remove gaskets from stock muffler crossover slips and install them into the supplied slip-on mufflers. If needed, replacement gaskets may be purchased through your dealer (HD Part #65927-00).
6. Position the stock clamps with hex head as shown in **Figure 1** and slide them onto the slip-on mufflers.
7. **NOTE: THE MUFFLER WITH THE COBRA LOGO WILL ALWAYS BE THE REAR MUFFLER.** Slide the mufflers onto the head pipes (reverse the order of removal) until the mounting holes align and crossover slips engage.
8. Fasten the mufflers using the stock mounting bolts in the same manner as stock but **do not tighten**.

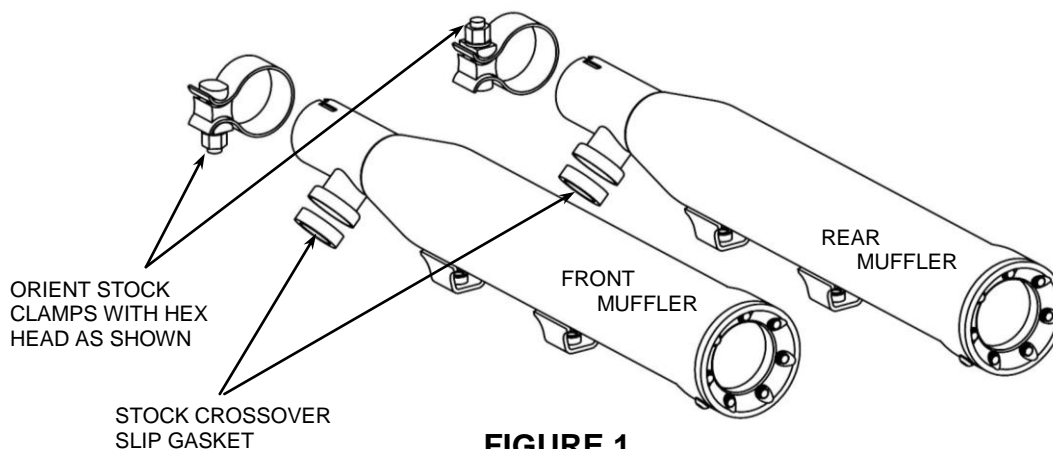

**FIGURE 1**

POSITION OF MUFFLERS AND MOUNTING BRACKETS SHOWN ABOVE MAY VARY FROM ACTUAL APPLICATION

Continued on Page 2

**DISCLAIMER: NOT LEGAL FOR SALE OR USE IN CALIFORNIA ON ANY POLLUTION CONTROLLED MOTOR VEHICLES.**

**Anything's Possible.®**

8. Check the alignment of the front and rear mufflers and make sure they are parallel. Check that the crossover slips remain engaged.
9. Tighten the mufflers to the mounting bracket.
10. Tighten the head pipe flange nuts to factory specifications.
11. Tighten the muffler clamps. (NOTE: The muffler clamps should be flush with the end of the muffler when tightened. See **Figure 2**. If the muffler clamps are slid forward past the slots on the slip collar the clamps will not tighten the mufflers properly. Also, make sure the clamp spacer is not over the slots. The slots need to be covered by the clamp band so that it seals the slots properly. Rotate the clamp if necessary).
12. Align the heat shields and tighten the heat shield clamps. Verify that the gap, where the mufflers meet stock heat shields, is similar to the gap the stock mufflers allotted.
13. Reinstall the head pipe support clamp and hardware. Tighten to factory specifications.
14. Tighten any remaining loose hardware to factory specifications.
15. **IMPORTANT: Before starting your engine remove all fingerprints from chrome with a quality wax or chrome polish. Failure to do so can cause discoloration. Due to fluctuations in fuel delivery settings, timing, etc., Cobra Engineering does not warrant against chrome discoloration.**

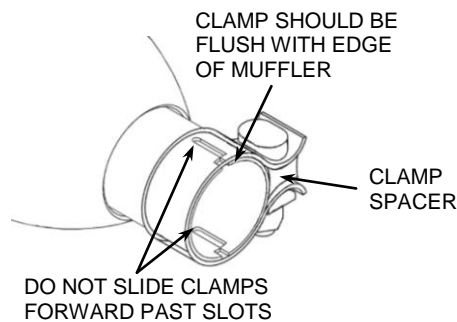

**FIGURE 2**

**IMPORTANT:** To achieve optimum performance from your new mufflers it is suggested that you install a Cobra Fi2000® Digital Fuel Processor.

**DISCLAIMER:** NOT LEGAL FOR SALE OR USE IN CALIFORNIA ON ANY POLLUTION CONTROLLED MOTOR VEHICLES.