

Items Supplied >

1 - INTAKE COVER W/ SCREEN / RING ASSEMBLY
1 - K&N® VENTURI AIR FILTER
1 - BASE MOUNTING PLATE
1 - BILLET VELOCITY STACK
1 - SUPPORT BRACKET
1 - INTAKE GASKET
2 - O-RING, SILICONE
2 - BREATHER HOSE, SPORTSTER
2 - BREATHER BOLT, 1/2"-13 X 1"
3 - BOLT, 1/4"-20 X 7/8", BUTTONHEAD W/ LOCK PATCH
3 - BOLT, 1/4"-20 X 1/2", BUTTONHEAD W/ LOCK PATCH
3 - LOCK WASHER, 1/4" TOOTHED

Application(s) >

HARLEY:
SPORTSTER 2004 - 2013

Instruction Manual >

606-0103 - 01/02/03/04

Page 1 of 2

Read all instructions carefully and completely before installing your new POWRFLO™ Intake.

1. Remove the (2) allen bolts from the center of the stock air cleaner to remove the cover. Remove the (3) bolts securing the air filter. Remove the stock (2) breather bolts from the cylinder heads. Discard the air box, air filter, hardware and seals/gaskets.
NOTE: Some California models will have a charcoal canister vent tube that must be disengaged before removing air box. Remove and save the vent tube grommet from the stock air box.
2. Place the supplied o-rings onto both supplied breather bolts. Insert the breather bolts through the openings in the supplied support bracket and begin threading into the cylinder heads. Insert the supplied gasket between the support bracket and throttle body and line up all the holes, then snug the breather bolts, but do not fully tighten.
3. Insert the (2) supplied breather hoses through the mounting plate and into the velocity stack with the hoses rotated outward, as shown in Figure 1. Make sure the breather hoses are bottomed out in the back of the velocity stack.
NOTE: California models will need to install the vent tube grommet into the designated hole in the mounting plate, see Figure 1.
4. Insert (3) supplied 1/4"-20 x 7/8" buttonhead bolts with lock washers through the mounting holes in the velocity stack and base mounting plate, then position on top of the installed support bracket (Step 2), intake gasket and start threading the buttonhead bolts into the throttle body, but do not tighten. See Figure 1.
5. Snug the (3) buttonhead bolts evenly, and then fully tighten them to the throttle body. Fully tighten the (2) breather bolts from Step 2.
6. Insert outer end of rubber hoses over nipples on breather bolts.
California Models: Insert the charcoal canister vent tube through the grommet installed in Step 3.
7. Place the supplied K&N® filter onto the velocity stack. Insert the round intake screen into the chrome ring so the screen sits inside the edge of the ring. Place the ring and screen between the legs of the naked chrome intake cover as shown in Figure 2.
8. Place the naked intake cover, ring and screen assembled in Step 7, over the air filter and align each leg to the base mounting plate threaded holes. Be sure screen sits at a 45 ° angle to the bottom leg, and C/V logo'd leg is at the upper left position. Insert the (3) supplied 1/4"-20 x 1/2" buttonhead bolts through the intake cover and into the base mounting plate, see Figure 2. Double check all parts are aligned properly and tighten securely.

* Cobra® recommends you always wear a helmet while riding. Please never operate your motorcycle while under the influence of alcohol and/or drugs. Enjoy the new look of your motorcycle and please ride safely.

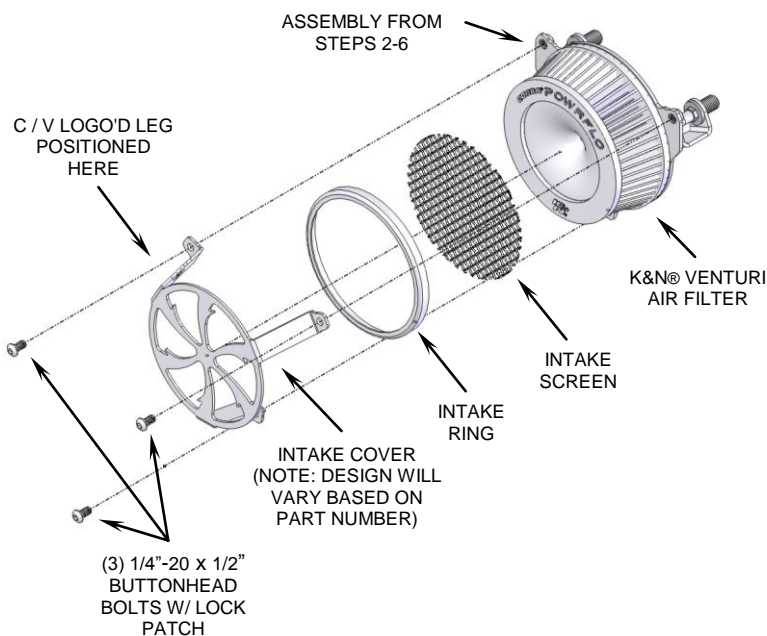
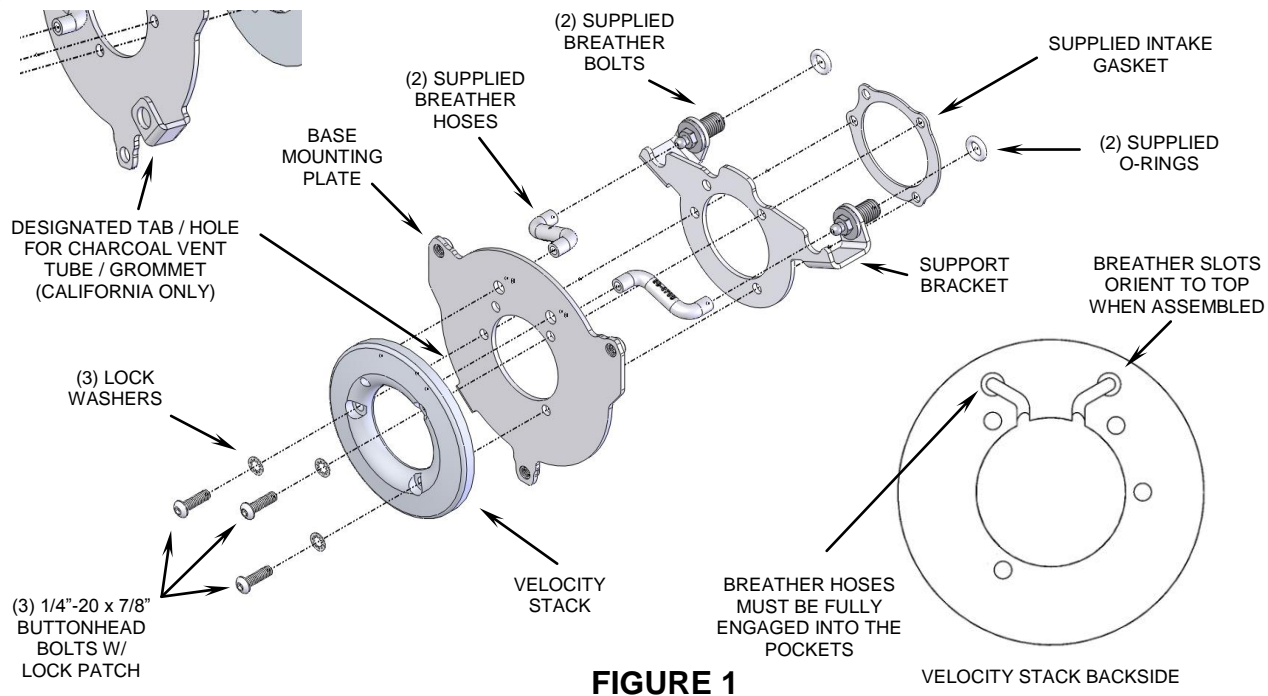

CALIFORNIA CUSTOMERS:

In California, aftermarket parts that have been identified specifically as replacement parts or that have received an Air Resources Board Executive Order may be used on street motorcycles.

All other emissions related aftermarket parts are for competition use only.

IMPORTANT: To achieve optimum performance from your new POWRFLO™ Air Intake it is suggested that you install a Cobra Fi2000® Digital Fuel Processor.