

Items Supplied >

- | | |
|--|--------------------|
| 1 - K&N® CONE AIR FILTER | 3 - FLAT WASHERS |
| 1 - HOSE CLAMP | 2 - BREATHER HOSES |
| 1 - PLATED TUBE ASSEMBLY | 1 - MEDIUM O-RING |
| 1 - BILLET ADAPTER PLATE | 1 - LARGE O-RING |
| 1 - BACKING PLATE | |
| 1 - INTAKE GASKET | |
| 2 - SMALL O-RING, SILICONE | |
| 2 - BREATHER BOLT, 3/8"-16 X 1" | |
| 3 - BOLT, 1/4"-20 X 7/8", BUTTONHEAD W/ LOCK PATCH | |
| 3 - LOCK WASHER, 1/4" INTERNAL TOOTHED | |
| 3 - BOLT, 1/4"-20 X 1", BUTTONHEAD W/ LOCK PATCH | |
| 1 - ZIPTIE, 4" #18 TEST | |

Application(s) >

HARLEY:	
SOFTAIL	2000-15
ROCKER	2008-11
DYNA	2000-17
DYNA SWITCHBACK	2012-16
DRESSER	1995-07
NOTE: DOES NOT FIT CVO OR S MODELS.	

Instruction Manual >

606-0102-06

Page 1 of 3

Read all instructions carefully and completely before installing your new air intake.

- Remove the allen bolt from the center of the stock air cleaner to remove the cover. Remove the (3) bolts securing the air filter. Then remove and discard the air filter, air box and seals/gaskets.
NOTE: For 2012 Dyna models, disengage the wire connector and cap from the backside of the air box.
- Remove and discard the (2) stock breather bolts, (2) stock o-rings, and the stock breather hoses from the cylinder heads.
- Place the medium and large o-rings onto the grooves of the billet adapter plate. A small amount of grease may be needed to hold the o-rings into position. See **FIGURE 1**.
- Starting with the billet adapter plate, stack all the parts together in the proper order according to **FIGURE 1**. Make sure the o-rings are seated properly in the grooves of the billet adapter plate.

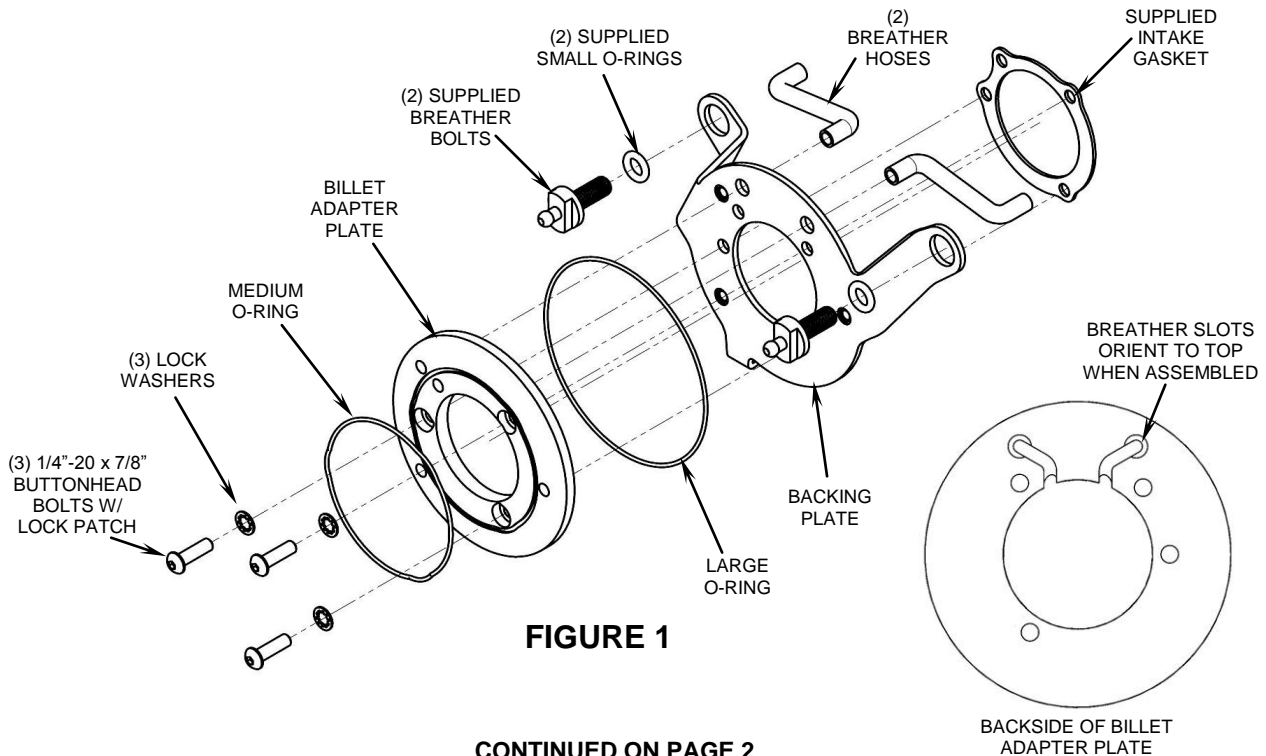

DISCLAIMER: NOT LEGAL FOR SALE OR USE IN CALIFORNIA ON ANY POLLUTION CONTROLLED MOTOR VEHICLES.

5. Insert (3) supplied 1/4"-20 x 7/8" buttonhead bolts with lock washers through the mounting holes in the billet adapter plate, backing plate, and intake gasket.
6. While holding that assembly together with one hand, insert the (2) supplied breather hoses through the backing plate and into the billet adapter plate with the hoses rotated outward, as shown in **FIGURE 1**. Make sure the hoses are bottomed out in the back of the billet adapter plate.
7. Align all the components with the throttle body and start threading the (3) buttonhead bolts into the throttle body. Snug the bolts but do not tighten at this time.
8. Place the supplied small o-rings onto both supplied breather bolts. Insert the breather bolts through the support bracket openings and into the cylinder heads and lightly snug. See **FIGURE 2**.
9. Now snug the (3) buttonhead bolts evenly, and then fully tighten them to the throttle body. Tighten the (2) breather bolts.
10. Insert the outer ends of rubber hoses over the nipples on the breather bolts.
11. **For 2012 Dyna models:** Use the supplied ziptie to secure the wire connector/cap to the support bracket tab. See **FIGURE 2**. *NOTE: Secure ziptie around the connector, DO NOT ziptie around wires.*

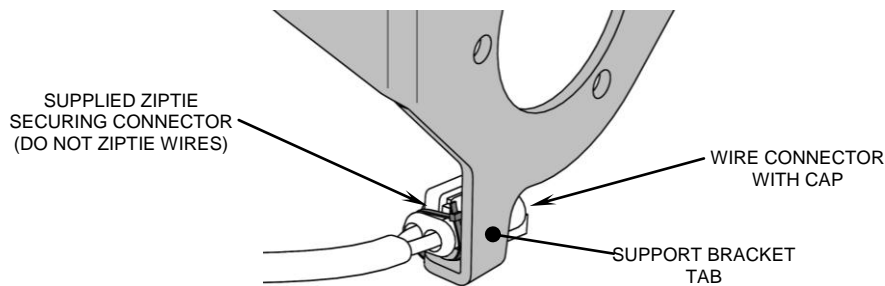
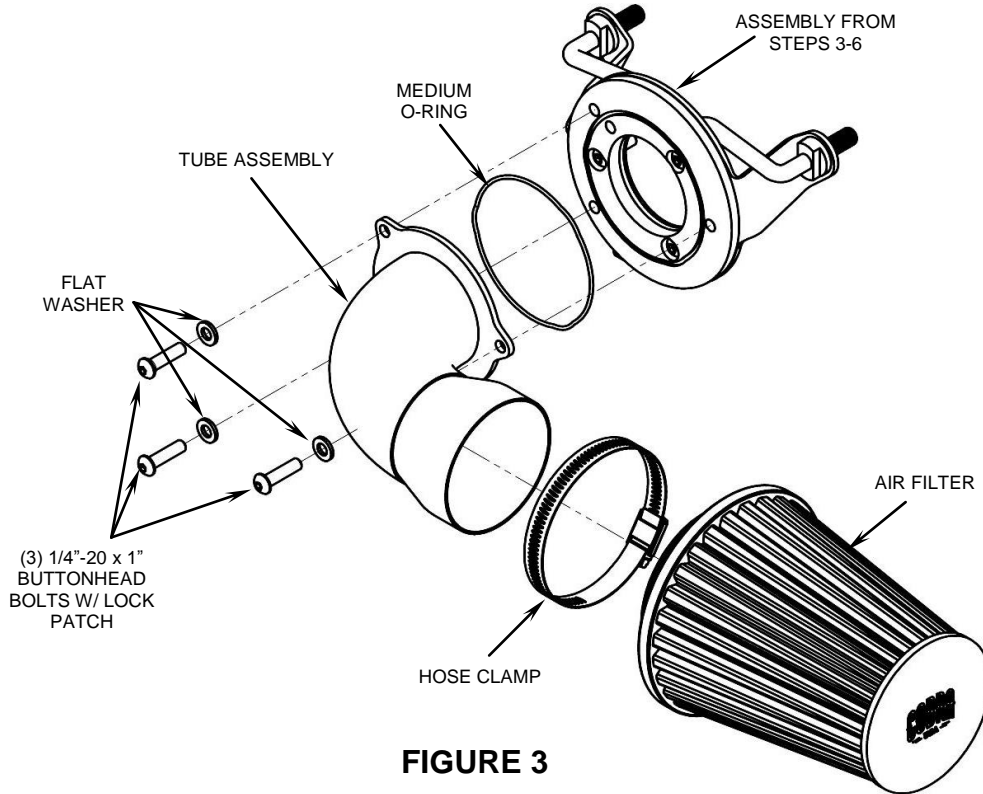

FIGURE 2

12. Make sure the medium sized o-ring is seated properly in the groove on the billet adapter plate and then attach the tube assembly using the supplied 1/4"-20 x 1" buttonhead bolts with lock patch and the supplied flat washers. See **FIGURE 3**. Tighten the three bolts evenly.
13. Place the supplied HS-48 clamp around the rubber boot of the K&N® filter so that the clamp screw will be on the inside and facing down. Then slide the filter onto the tube as far as it will go. Align the logo on the front cover so that it is level with the ground and tighten the clamp. See **FIGURE 3**.
14. Verify all the bolts are tight and then wipe off any fingerprints with a clean microfiber cloth.

CONTINUED ON PAGE 3



CLEANING INSTRUCTIONS: To clean any black portions of the cone air intake system use a liquid based soap detergent, such as dishwashing soap applied with a soft cloth and rinse with clean water. Note: Avoid abrasive cleaning methods such as granular or dry cleansers, simple green, Scotch-Brite or steel wool pads. Abrasives may breach the coating and shorten life.

DISCLAIMER: NOT LEGAL FOR SALE OR USE IN CALIFORNIA ON ANY POLLUTION CONTROLLED MOTOR VEHICLES.