

Items Supplied >

- 1 - TRUNK GUARD BAR
- 1 - LEFT SIDE MOUNTING BRACKET
- 1 - RIGHT SIDE MOUNTING BRACKET
- 4 - 5/16 HEX BOLT
- 4 - 5/16 NYLOCK FLANGE NUT
- 4 - 5/16 BUTTON HEAD BOLT
- 4 - FLAT WASHERS

Application(s) >

HARLEY:
TRIKE FREEWHEELER 15-16

Instruction Manual >

602-3100

Page 1 of 2

Read all instructions carefully and completely before installing your new Trunk Guard!

1. Open the trunk lid and remove any loose items from the trunk. Also remove the trunk liner to expose the 4 hex bolts on the floor of the trunk that attach the trunk to the frame. See **FIGURE 1**.
2. Remove one hex bolt from the bottom of the trunk. ONLY REMOVE ONE at this time.
3. Mark the length of the old short hex bolt on the supplied longer hex bolt. Apply blue loctite to 3/8" of the screw threads of the supplied longer bolt above this mark so that the loctite will engage into the threads of the frame. See **FIGURE 2**.
4. Insert this bolt through the washer and trunk and into the threads of the frame. Tighten the bolt to 18 ft-lbs.
5. Do this for the remaining three hex bolts and tighten to 18 ft-lbs.

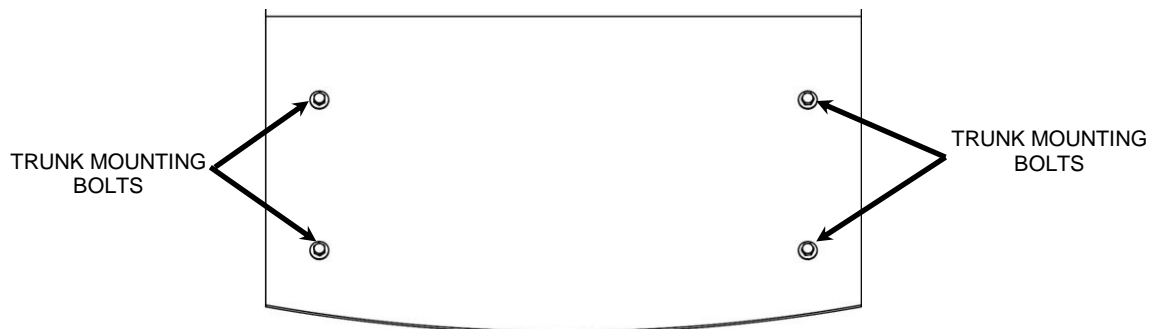

FIGURE 1

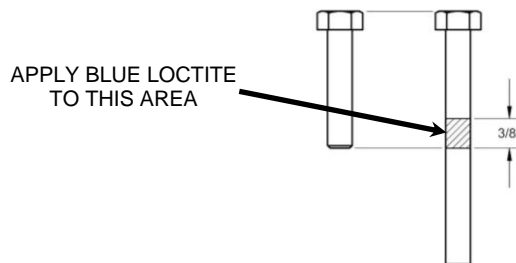

FIGURE 2

* Cobra® recommends you always wear a helmet while riding. Please never operate your motorcycle while under the influence of alcohol and/or drugs. Enjoy the new look of your motorcycle and please ride safely.

7. From underneath the trunk, use the supplied nylock flange nuts to attach the right mounting bracket onto the ends of the trunk bolts. See **FIGURE 3**. The right mounting bracket will be stamped with a part number ending in an "R". Snug the bolts but **DO NOT TIGHTEN** at this time.
8. Do the same for the left mounting bracket. See **FIGURE 3**. The left mounting bracket will be stamped with a part number ending in an "L". Snug the bolts but **DO NOT TIGHTEN** at this time.
9. Carefully attach the trunk guard bar to the brackets using the supplied button head screws and washers. See **FIGURE 3**. Snug the screws but **DO NOT TIGHTEN** at this time.
10. When everything is straight and parallel with the body lines of the trunk, tighten the trunk guard bar to the brackets first. Then tighten the nylock flange nuts that secure the mounting brackets to the underside of the trunk.
11. Re-install the trunk liner.
12. Make sure to check the tightness of all (4) flange nuts and (4) button head screws on the trunk guard after the first ride and after the first 500 miles.

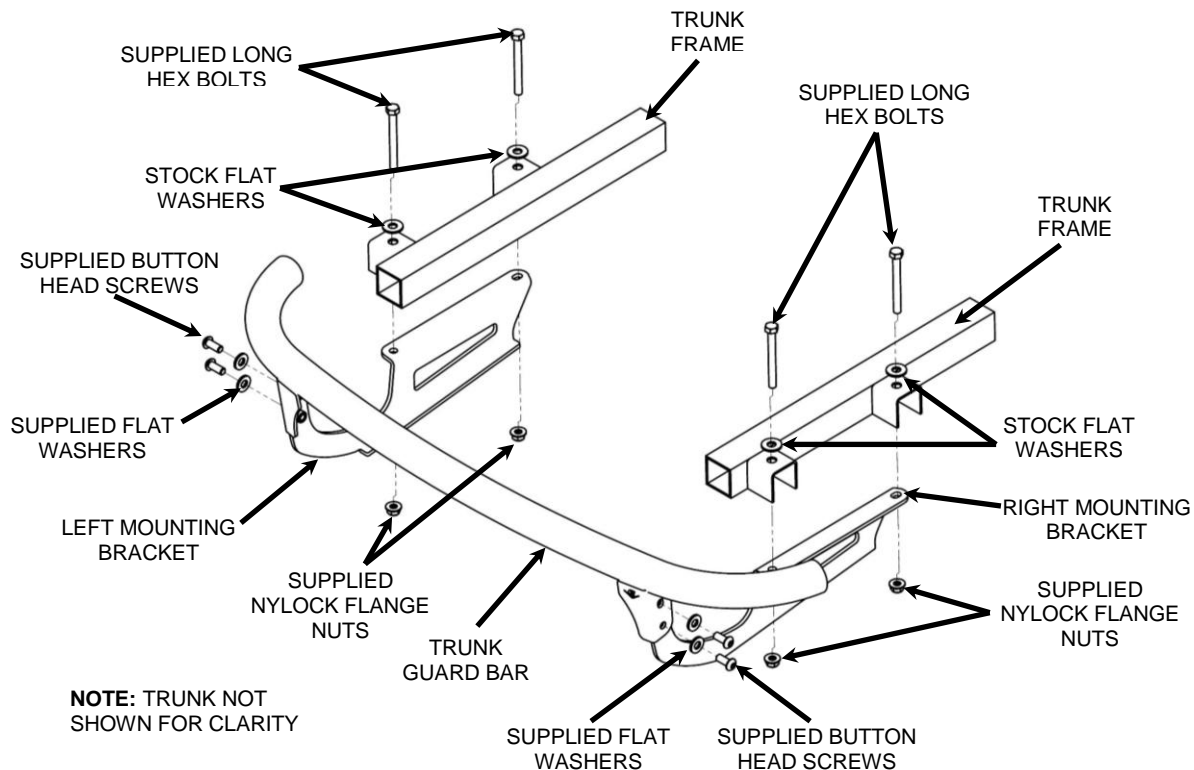

FIGURE 3