

Items Supplied >

-SEE TABLE 1 ON PAGE 2.

Application(s) >

Harley:
DRESSER 1997-2008

FLHX and FLTR models require
Harley's antenna relocation kit P/N
76326-00A

Instruction Manual >

602-2700

Page 1 of 2

NOTE: See **FIGURE 1**. This Cobra Detachable Tour Pack Mount (P/N 602-2700) is compatible with both the Cobra rear docking kit (P/N 602-2103) and the Harley-Davidson rear docking kit (P/N 53804-06).

NOTE: You must install a rear docking kit on the bike before installing this Tour Pack mount.

INITIAL INSTALLATION PROCEDURE

1. See **TABLE 1**. Check the fitment of the Tour Pack mount (5) on the bike, attaching it by following steps #6-8 below. The front and rear slots (indicated in **FIGURE 3**) of the Tour Pack mount (5) should fully engage with the plastic bushings, on both sides of the bike, on both the rear and front mounting bushings (indicated in **FIGURE 1**) for the rear docking kit. If any do not, loosen any hardware necessary in order to adjust the locations for the mounting bushings for the rear docking kit until the slots fully and securely engage with them. **Re-torque** any loosened hardware to their specified torques, then detach the Tour Pack from the bike.
2. See **TABLE 1**. Starting with the rear center hole of the Tour Pack, slide five ¼-20 hex head bolts (1A or 1B depending on Tour Pack, see **TABLE 1**), with one ¼" I.D. washer (2) each, through the five holes in the Tour Pack (not shown in **FIGURE 3**), the matching holes in the Tour-Pack support tube (3), one aluminum tube spacer (4) each, and the Tour Pack mount (5) as shown in **FIGURE 3**.
3. See **TABLE 1**. Secure each bolt with a ¼" I.D. washer (2) and ¼-20 nylon locknut (6) on the underside of the Tour Pack mount (5) as indicated in **FIGURE 3**, but **DO NOT TIGHTEN** at this time.
4. Make sure that the Tour Pack support tube (3) fits flush in all five of the grooves of the aluminum tube spacers (4), as shown in **FIGURE 2**.
5. Incrementally tighten all screws installed in step #1 in a crosswise pattern to a **TORQUE OF 96-120 IN-LBS.**

TOUR-PACK ATTACHING PROCEDURE

6. Slide the front slots (indicated in **FIGURE 3**) of the Tour Pack mount (5) into the front mounting bushing of the rear docking kit (indicated in **FIGURE 1**). Make sure to insert the front slots all the way onto the bushings.
7. Slowly rotate the rack downward until the rear slots (indicated in **FIGURE 3**) slip over the rear mounting kit bushings (indicated in **FIGURE 1**).
8. Pull backward on both detachable latch knobs (as indicated in **FIGURE 2**) and then push downward on the rack to allow the rack's slots to sit completely in both the front and rear mounting kit bushings. Then release the detachable latch knob to fully engage the latch pin underneath the rear mounting kit bushing, as shown in **FIGURE 2**.
9. Before each ride, ensure that the detachable latches are fully engaged underneath the rear mounting bushings (as indicated in **FIGURE 2**).
10. Check the tightness of all the screws before and after the first ride, and after the first 500 miles.

Continued on Page 2

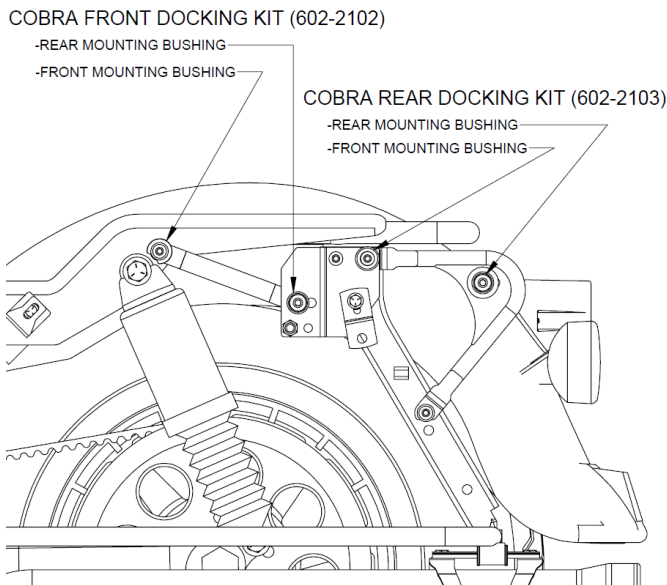

FIGURE 1, AVAILABLE DOCKING KITS (LEFT SIDE SHOWN)

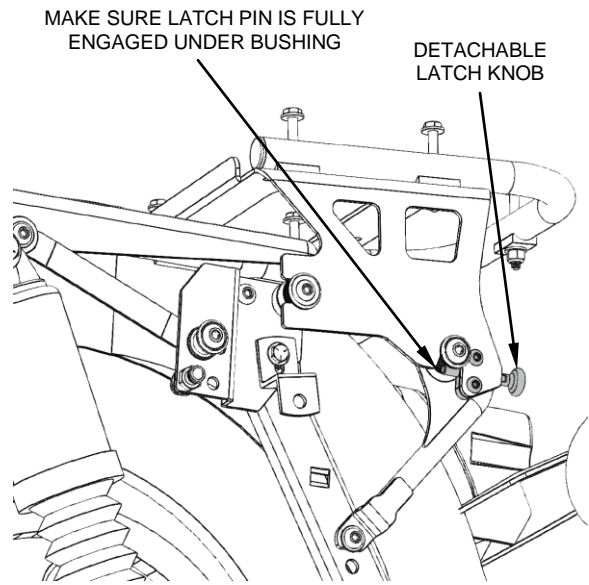

FIGURE 2, CORRECT FITMENT (LEFT SIDE SHOWN, TOUR PACK NOT SHOWN)

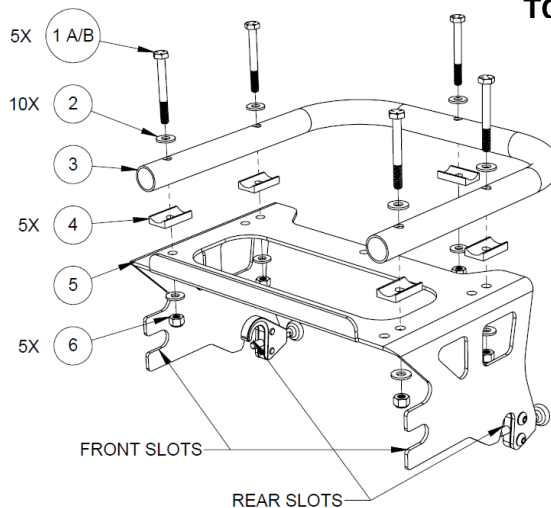

FIGURE 3, TOUR PACK MOUNT COMPONENTS (TOUR PACK NOT SHOWN)

Item	Description	Notes	Quantity	
1	A	1/4-20 X 1.75" hex head screw	(for 2006 and later King Tour-Pak, and Leather Tour-Pak)	5
	B	1/4-20 X 2.25" hex head screw	(for 2005 and earlier King Tour-Pak, and Chopped Tour-Pak)	5
2	1/4" I.D. washer		10	
3	Tour Pack support tube		1	
4	Aluminum tube spacer		5	
5	Tour Pack mount		1	
6	1/4-20 nylon locknut		5	

TABLE 1, ITEMS SUPPLIED