

COBRA

Items Supplied >

- 1 – RIGHT MUFFLER ASSEMBLY
- 1 – LEFT MUFFLER ASSEMBLY
- 4 – 5/16" FLAT WASHERS

Application >

KAWASAKI	VN1700 NOMAD	09-14
	VN1700 VOYAGER	09-19
	VN1700 VAQUERO	11-19

Instruction Manual >

4230

Page 1 of 2

Read all instructions carefully and completely before installing your new slip-on mufflers!

1. Remove the saddlebags carefully.
2. If equipped, disconnect the O2 sensor from the wiring harness.
3. Loosen the large diameter heatshield clamps around both stock mufflers. Leave the right side heatshield in place.
4. Remove and save the mounting hardware securing the stock mufflers to the brackets. Loosen the muffler clamps and pull the mufflers free from the headpipes. Remove the muffler clamps from the mufflers for later reuse. The stock gaskets will also be reused; do not remove them from the headpipes.
5. If equipped, remove the O2 sensor from the stock muffler. Remove the O2 sensor bung plug and copper washer from the new right side muffler and install the O2 sensor in its place. See **FIGURE 1**. If the motorcycle is **not** equipped with an O2 sensor than leave the bung plug and copper washer in place.
6. Remove the heatshield from the stock left muffler and install it onto the new left muffler in the same way as stock. Do not tighten clamps fully at this time.
7. Install the stock muffler clamps onto the headpipes. **NOTE:** Position clamps in the same manner as the stock setup with the bolt/nut to the inside and facing the ground. Slide the mufflers onto the headpipes until the mounting holes align with frame mounts. Place the supplied washers onto the stock bolts and fasten the mufflers to the mounts. **Do not tighten at this time.** The washers must be placed under the heads of the stock bolts otherwise the bolts will not tighten properly.

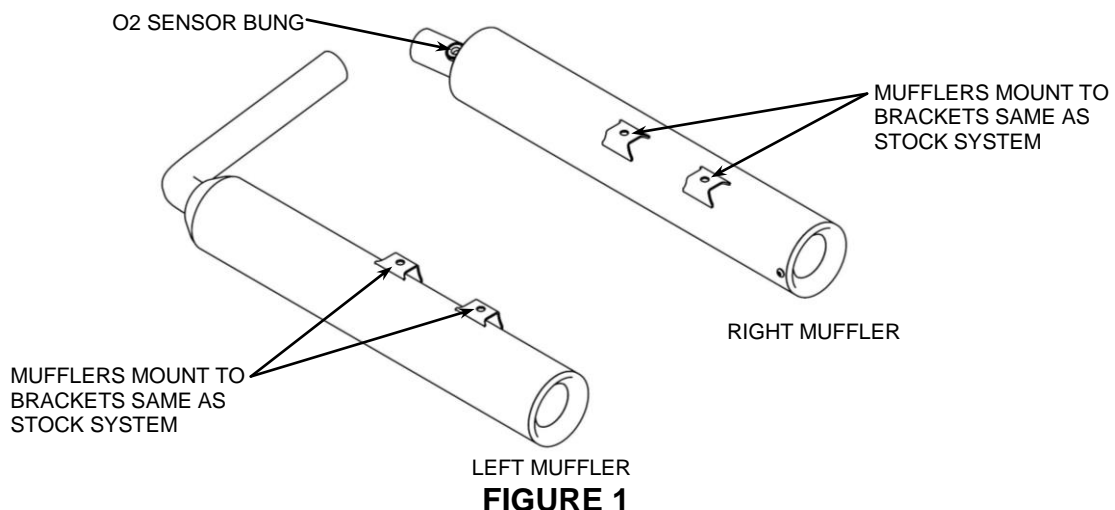

California does not allow the use of aftermarket exhaust systems that remove original equipment catalyysts, (except for racing use only) unless the Air Resources Board has issued an Executive Order for that system.

* *Cobra recommends you always wear a helmet while riding. Please never operate your motorcycle while under the influence of alcohol and/or drugs. Enjoy the new look of your motorcycle and please ride safely.*

Anything's Possible.®

8. Rotate the mufflers as needed so the tips are level with the ground and mufflers are parallel with each other.
9. Check all clearances and alignments then tighten the mounting bolts to factory specifications.
10. Then fully tighten the supplied muffler clamps.
11. Verify the gap where the mufflers meet the stock heatshields is similar to the gap the stock mufflers allotted; then tighten the left and right heatshield clamps fully. Reinstall saddlebags carefully.
12. **IMPORTANT: Before starting your engine remove all fingerprints from chrome with a quality wax or chrome polish. Failure to do so can cause chrome discoloration. Due to fluctuations in fuel delivery settings, timing, etc., Cobra Engineering does not warrant against chrome discoloration.**

IMPORTANT: To achieve optimum performance from your new mufflers it is suggested that you install a Cobra Fi2000® Digital Fuel Processor. (Cobra Part# 92-1965 for 49 state models and Part# 92-1965-50 for CA models.)