

# COBRA

## Items Supplied >

- 1 – FRONT EXHAUST W/ HEATSHIELD
- 1 – REAR EXHAUST W/ HEATSHIELD
- 1 – MUFFLER MOUNTING BRACKET
- 2 – BILLET MUFFLER TIPS
- 5 – HOSE CLAMP HS-24
- 2 – HOSE CLAMP HS-28
- 2 – HEX FLANGE BOLTS M10 X 30 mm
- 2 – HEX FLANGE BOLTS 5/16" X 5/8" WITH THREADL'K
- 2 – BUTTONHEAD BOLTS S.S.-1/4" X 3/8" POLISHED

## Application(s) >

YAMAHA V-STAR 1300 07-13

## Instruction Manual >

2625

Page 1 of 2

**PRIOR TO INSTALLATION, MAKE SURE YOUR STOCK GASKETS ARE IN GOOD SHAPE. IF YOU HAVE ANY DOUBTS AS TO THEIR CONDITION, REPLACE THEM.**

1. Loosen the right floorboard bolts to allow the floorboard to tilt down for easier exhaust removal and installation.
2. Remove cover over the oxygen sensor connector on right side of motorcycle above the exhaust, it is retained by three button head allen bolts. On the female connector pull the tab that faces the male connector outward and slide the male connector out of it to allow the oxygen sensor to be removed with the exhaust assembly, see Figure 1. NOTE: The Oxygen Sensor will be installed into the Cobra Exhaust, it may be used in combination with a closed loop Fi2000® Fuel Module, Cobra part Number: 92-1774CL.

REMOVE ZIPTIE BY PULLING TAB OUTWARD, THEN PULLING MALE PORTION OF ZIP TIE BACK OUT.

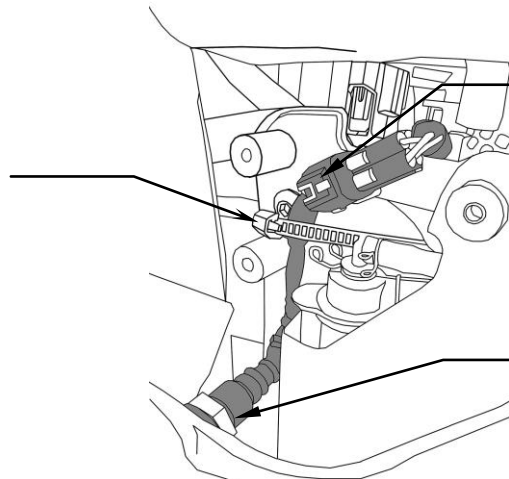

DEPRESS TAB HERE TO RELEASE MALE O<sub>2</sub> SENSOR CONNECTOR

O<sub>2</sub> SENSOR INSTALLED IN DRAGSTER EXHAUST UPPER PIPE

**FIGURE 1**

3. Remove the acorn nuts securing the stock head pipes, these nuts will be used again later with the Cobra system. Remove the bolts securing the stock exhaust to the stock exhaust-mounting bracket, remove the stock exhaust as well as the stock exhaust-mounting bracket, these components will not be reused. Once the stock exhaust has been removed, remove the oxygen sensor from the stock exhaust and set aside.

**\* Cobra® recommends you always wear a helmet while riding. Please never operate your motorcycle while under the influence of alcohol and/or drugs. Enjoy the new look of your motorcycle and please ride safely.**

4. Install the Cobra supplied exhaust bracket using the supplied M10 X 30 mm Flange bolts, **DO NOT TIGHTEN AT THIS TIME**, see Figure 2.
5. Install the stock O<sub>2</sub> sensor into the oxygen sensor bung on the supplied rear headpipe/muffler assembly, tighten it securely.

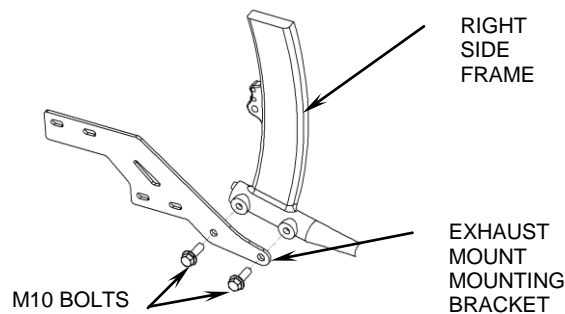

**FIGURE 2**

6. Install the front and rear pipes on to the motorcycle, secure with stock acorn nuts but **DO NOT TIGHTEN AT THIS TIME**. Align mufflers with mounting holes in the exhaust-mounting bracket and install 5/16" flange bolts, **DO NOT TIGHTEN AT THIS TIME**.
7. Make sure the front and rear exhaust assemblies are parallel to the ground then tighten the following in order, head pipe flanges to the motor (slowly tighten opposing nut), muffler bracket to the frame, muffler assemblies to the muffler bracket, recheck that headpipe acorn nuts are tight. Reconnect the O<sub>2</sub> sensor wire to the stock harness, or inline with a closed loop Fi2000®. Reinstall cover over oxygen sensor connector area and 3 allen bolts removed earlier.
8. On the heat shields unscrew the remaining hose clamps and feed the tail end of the clamp through the clips on the inside of the heat shields. The screw end of the hose clamp should be accessible for tightening but not visible when the heat shields are mounted to the pipes. Note: the larger HS 28 clamps go at the rear of each heatshield; one is supplied for the front and rear heatshield.
9. To install the front heatshield, first slide the rear portion of the heatshield over the muffler, continue to slowly slide it forward pushing the front of the shield gently into place between the frame and motor (Hint: Spread the hose clamps apart slightly to make it easier to slide them over the muffler assembly and head pipes). Make sure the muffler clamps don't interfere with the heatshields and are aligned. Snug the heat shield clamps but **DO NOT TIGHTEN**.
10. Install the rear heatshield the same way as the front heat shield.
11. Install one billet tip on each heatshield making sure the ends of the tips are even with each other. Fasten the tips with the supplied 1/4" buttonhead screws making sure they snug up against the heatshield leaving no gap between the tip and heatshield when tightened. **If it is difficult to slide the tips into the heatshields loosen the clamps on the heatshield, failure to do this may cause damage to the chrome tips.**
12. Tighten the clamps on the heatshields.
13. Retighten floorboard assembly with the stock bolts and tighten to factory specifications.
14. Make sure all the hardware (brackets, headpipes, heatshields, mufflers and baffles) has been tightened appropriately and cleaned before starting your motorcycle.

**IMPORTANT:** It is recommended that a Fi2000® Closed Loop Fuel Module be used with this exhaust system, Cobra Part Number: 92-1774CL. CA models use 92-1774CL-50

**Before starting your engine remove all fingerprints from chrome with a quality wax or chrome polish. Failure to do so can cause discoloration.**

California does not allow the use of aftermarket exhaust systems that remove original equipment catalysts, (except for racing use only) unless the Air Resources Board has issued an Executive Order for that system.