

COBRA

Items Supplied >

1 – FRONT HEADPIPE W/HEATSHIELD
1 – REAR HEADPIPE / MUFFLER W/ HEATSHIELD
1 – EXHAUST MOUNT BRACKET
5 – HOSE CLAMPS HS-24
2 – HOSE CLAMPS HS-28
1 – CLAMP, 27-61MSC
2 – BOLT, HEX 5/16-18 x 5/8
2 – BOLT, M10-1.25 X 30mm, HEX FLANGE
1 – WIRE HARNESS, O₂ SENSOR

Application(s) >

YAMAHA STRYKER

2011-2018

Instruction Manual >

2230

Page 1 of 2

PRIOR TO INSTALLATION, MAKE SURE YOUR STOCK HEADPIPE GASKETS ARE IN GOOD SHAPE. IF YOU HAVE ANY DOUBTS AS TO THEIR CONDITION, REPLACE THEM.

Read all instructions carefully and completely before installing your new exhaust system

1. Loosen the right footpeg assembly to help provide clearance for exhaust removal and installation.
2. Remove the small plastic cover located behind the rear headpipe and disconnect the O₂ sensor connector. (NOTE: Push-in the center pin on the fastener to release plastic cover).
3. Remove the stock exhaust system and stock exhaust mount. Save the (4) acorn nuts that attach the headpipes flanges to the cylinders for later use during installation.
4. Install the supplied exhaust mount bracket using the (2) supplied M10 x 30 mm hex flange bolts, but **DO NOT FULLY TIGHTEN**. See Figure 1.
5. Remove the O₂ sensor from the stock exhaust and install into the supplied front headpipe. Install front headpipe to the front cylinder using the stock acorn nuts from Step 3. **DO NOT TIGHTEN** at this time.

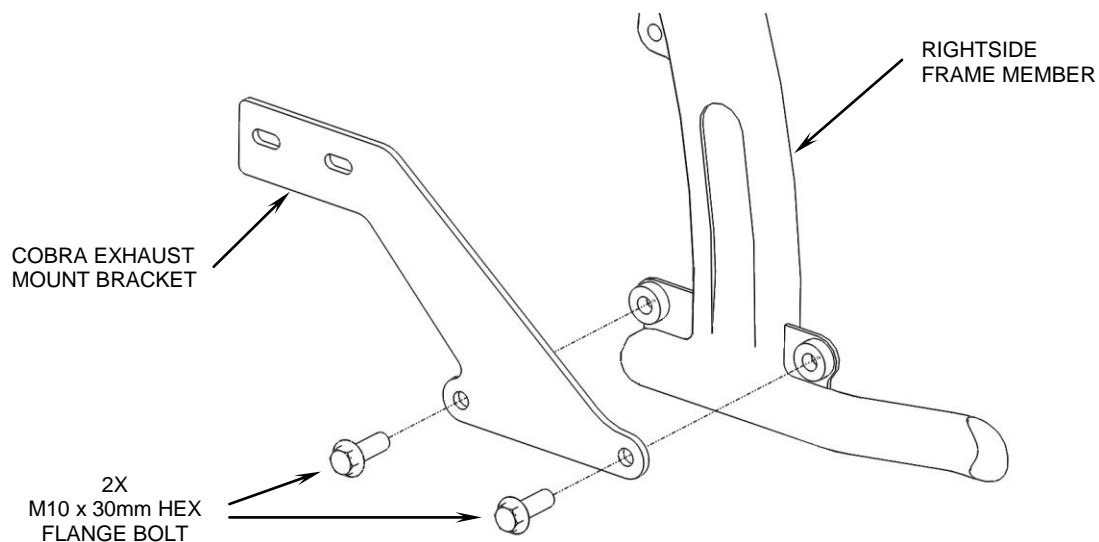

FIGURE 1

* *Cobra® recommends you always wear a helmet while riding. Please never operate your motorcycle while under the influence of alcohol and/or drugs. Enjoy the new look of your motorcycle and please ride safely.*

6. Place the supplied 27-61msc clamp onto the lower muffler slip then slide the rear headpipe / muffler assembly onto the front headpipe and into the rear exhaust port. Install rear headpipe to the rear cylinder using the stock acorn nuts from Step 3, but **DO NOT TIGHTEN**. See Figure 2 for clamp orientation.
7. Bolt the muffler assembly to the exhaust mount using the supplied 5/16 bolts. **DO NOT TIGHTEN**.
8. Make sure the front headpipe is fully inserted into the rear assembly and make sure the pipes are parallel with each other. Fully tighten the exhaust mount to the frame first, then the front and rear cylinder acorn nuts attaching the exhaust flanges, then the muffler to the exhaust mount. Tighten the 27-61msc clamp last. (NOTE: If the muffler clamp is slid past the slots on the slip collar the clamp will not tighten properly).
9. Plug O₂ sensor connector into the supplied O₂ sensor harness extension and plug the opposite end into the stock harness location. Make sure the extension harness is tucked away from exhaust system. Reinstall small plastic cover and fastener (NOTE: push pin out, install, then push pin flush).
10. Unscrew the hose clamps and feed the tail end of the clamp through the clips on the inside of the heatshields, the larger clamps go to the rear of the heatshields where they will rest on the muffler bodies, smaller ones to the front for the headpipes. The screw end of the hose clamp should be accessible for tightening but not visible when heatshields are mounted to the pipes, see Figure 3.
11. To install the front heatshield, first slide the rear portion of the heatshield over the muffler, continue to slowly slide it forward pushing the front of the shield gently into place between the frame and motor (Hint: Spread the hose clamps apart slightly to make it easier to slide them over the muffler assembly and headpipes). Make sure the muffler clamp doesn't interfere with the heatshields and is aligned as shown in Figure 2. Snug the heatshield clamps but **DO NOT TIGHTEN**.
12. Install the rear heatshield in the same manner as the front heatshield. Tighten all hose clamps.
13. Reinstall the right side footpeg and tighten bolts to factory specifications.
14. Make sure all the hardware (brackets, headpipes, heatshields, and mufflers) has been tightened appropriately and cleaned before starting your motorcycle.

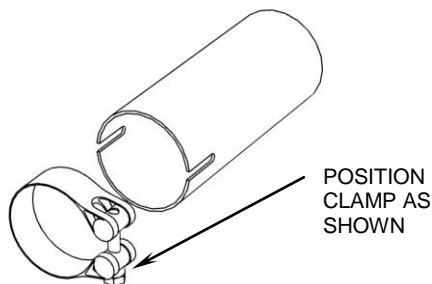

FIGURE 2
(FRONT VIEW)

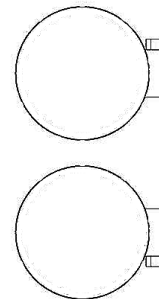

FIGURE 3
(FRONT VIEW)

IMPORTANT: Cobra highly recommends using a Fi2000® Fuel Management System to help eliminate lean conditions and popping sounds. (Cobra Part# 92-1770CL for 49 state models and Part# 92-1770CL-50 for CA models.)

- * Before starting your engine remove all fingerprints from chrome with a quality wax or chrome polish. Failure to do so can cause discoloration. Due to fluctuations in carburetor settings, timing, etc., Cobra Engineering does not warrant against chrome discoloration.

California does not allow the use of aftermarket exhaust systems that remove original equipment catalysts, (except for racing use only) unless the Air Resources Board has issued an Executive Order for that system.