

COBRA

Items Supplied >

- 1 - Front Exhaust
- 1 - Rear Exhaust
- 1 - Front Heat Shield w/clamps
- 1 - Rear Heat Shield w/clamps
- 1 - Bar Mounting Bracket
- 2 - Muffler Clamps #27-61MSC
- 1 - Nut, M10 Fine Thread
- 4 - 5/16" x 5/8" Hex Bolt
- 2 - Slider Brackets

Application >

HONDA AERO 750 04-09, 11-14

Instruction Manual >

1563SC

Page 1 of 2

PRIOR TO INSTALLATION, MAKE SURE YOUR STOCK GASKETS ARE IN GOOD SHAPE. IF YOU HAVE ANY DOUBTS AS TO THEIR CONDITION, REPLACE THEM.

1. Remove your stock exhaust system and large muffler bracket.
2. Attach the supplied Cobra bar mount bracket to the outside of the frame using the stock M10 bolts & nut along with the supplied M10 nut (See figure 1). **DO NOT TIGHTEN** at this time.
3. Loosen and move the right side floorboard out of the way to ease installation of the exhaust.
4. Install the rear head pipe using the stock acorn nuts but **DO NOT TIGHTEN** at this time.
5. Slide one supplied clamp #27-61MSC onto each muffler and position as shown in Figure 2.
6. Slide the rear muffler over the rear head pipe. Place one slider bracket inside the muffler bracket with the flat side of the bracket against the muffler bracket (see figure 2) and install two 5/16 x 5/8 hex bolts thru mounting bracket, muffler bracket and into the slider brackets.
7. Repeat step 6 for front head pipe and muffler making sure the front and rear mufflers are parallel.
8. Unscrew the remaining hose clamps and feed the tail end of the clamp through the clips on the inside of the heat shields. The screw end of the hose clamp should be accessible for tightening but not visible when the heat shields are mounted to the pipes.
9. Place the heat shields onto the head pipes and align on muffler as shown in Figure 2. You may need to loosen the muffler bolts to adjust the position of the muffler to the heat shields. Snug the heat shield clamps onto the head pipes but **DO NOT TIGHTEN** at this time. Rotate the muffler clamps so they don't interfere with the heat shields but are still accessible to tighten.
10. Tighten mount to frame and then the acorn nuts on the head pipes making sure to tighten evenly. Now, tighten the muffler clamps. (**NOTE: If the muffler clamps are slid to far up on the muffler or past the three slots, the clamps will not tighten.**) Next tighten mufflers to mount bracket.
11. Reinstall the right floorboard and tighten to factory specifications.
12. Make sure all hardware is tight before starting your motorcycle.

Before starting your engine remove all fingerprints from chrome with a quality wax or chrome polish. Failure to do so can cause discoloration. Due to fluctuations in carburetor settings, timing, etc., Cobra Engineering does not warrant against chrome discoloration.

** Cobra recommends you always wear a helmet while riding. Please never operate your motorcycle while under the influence of alcohol and/or drugs. Enjoy the new look of your motorcycle and please ride safely.*

Anything's Possible.®

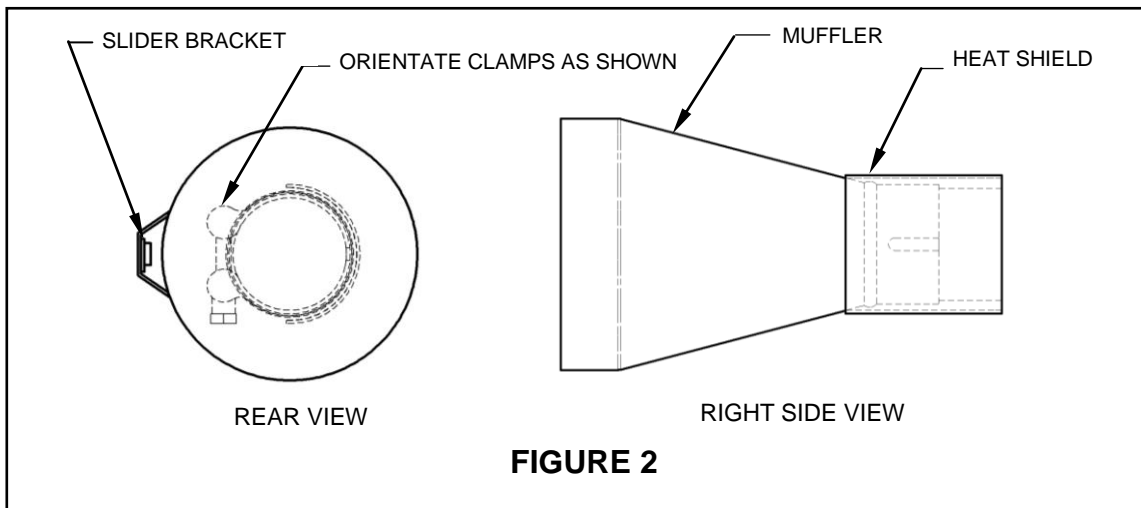
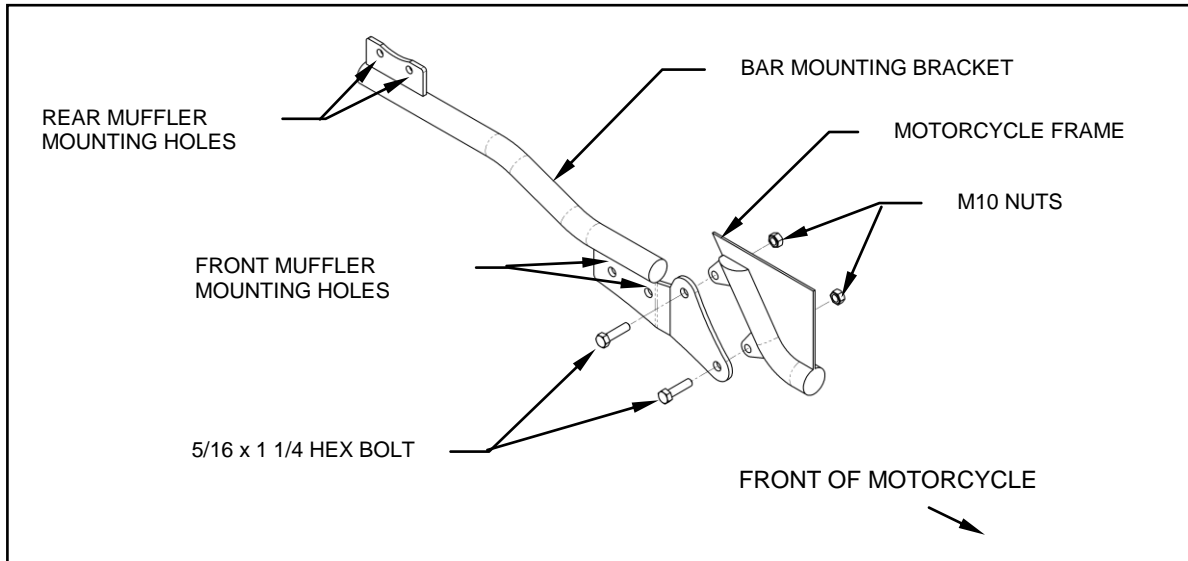

IMPORTANT: It is recommended that you re-jet your bike with a Cobra Jet Kit, available from Cobra part #92-1263.

Before starting your engine remove all fingerprints from chrome with a quality wax or chrome polish. Failure to do so can cause discoloration. Due to fluctuations in carburetor settings, timing, etc., Cobra Engineering does not warrant against chrome discoloration.

California does not allow the use of aftermarket exhaust systems that remove original equipment catalysts, (except for racing use only) unless the Air Resources Board has issued an Executive Order for that system.