

Items Supplied >

1 - LEFT SIDE EXHAUST ASSEMBLY
1 - RIGHT SIDE EXHAUST ASSEMBLY
2 - HEATSHIELDS (LEFT & RIGHT)
2 - CLAMP, HOSE HS-20
4 - BOLT, M8 x 20mm HEX FLANGE
2 - BOLT, M8 x 16mm BUTTONHEAD

Application(s) >

HONDA VALKYRIE

97-03

Instruction Manual >

1269

Page 1 of 2

PRIOR TO INSTALLATION, MAKE SURE YOUR STOCK HEADPIPE GASKETS ARE IN GOOD SHAPE. IF YOU HAVE ANY DOUBTS AS TO THEIR CONDITION, REPLACE THEM.

Read all instructions carefully and completely before installing your new exhaust system

RIGHT SIDE

1. Remove the engine guard mounting bolt and collar. See Figure 1.
2. Remove stock exhaust system and save the acorn nuts for later use.
3. Re-install engine guard collar and mounting bolt.

NOTE: COBRA 6 INTO 6 DRAG PIPES ARE PRE-ASSEMBLED IN THE SAME WAY THEY WILL APPEAR WHEN INSTALLED. MAKE SURE THE ORDER IS NOT CHANGED.

4. Install right exhaust assembly from front to rear. Front headpipe first, middle headpipe next, and then the rear headpipe last. Align the headpipes flanges to their respective exhaust port studs and attach one at a time using the stock flange nuts, but **DO NOT FULLY TIGHTEN**. See Figure 2.
5. Insert the (2) supplied M8 x 20mm hex flange bolts through the stock exhaust mount, middle headpipe mount and thread into the front headpipe mount as shown in Figure 1, but **DO NOT FULLY TIGHTEN**. Attach rear headpipe to the middle headpipe using (1) supplied buttonhead bolt.
6. Adjust and align the exhaust assembly so the slashcuts are all flush on the ends. Fully tighten the acorn nuts then the supplied M8 hex flange bolts and M8 buttonhead bolt.
7. Unscrew a supplied hose clamp and feed the tail end of the clamp through the clip on the inside of the heatshield. Install heatshield onto rear headpipe just behind footrest. NOTE: Heatshields are marked left and right.

LEFT SIDE

8. Repeat steps 1-7 on the left side.

IMPORTANT: It is recommended that you re-jet your bike with a Cobra Jet Kit, available from Cobra part #92-1269.

Before starting your engine remove all fingerprints from chrome with a quality wax or chrome polish. Failure to do so can cause discoloration.

* *Cobra® recommends you always wear a helmet while riding. Please never operate your motorcycle while under the influence of alcohol and/or drugs. Enjoy the new look of your motorcycle and please ride safely.*

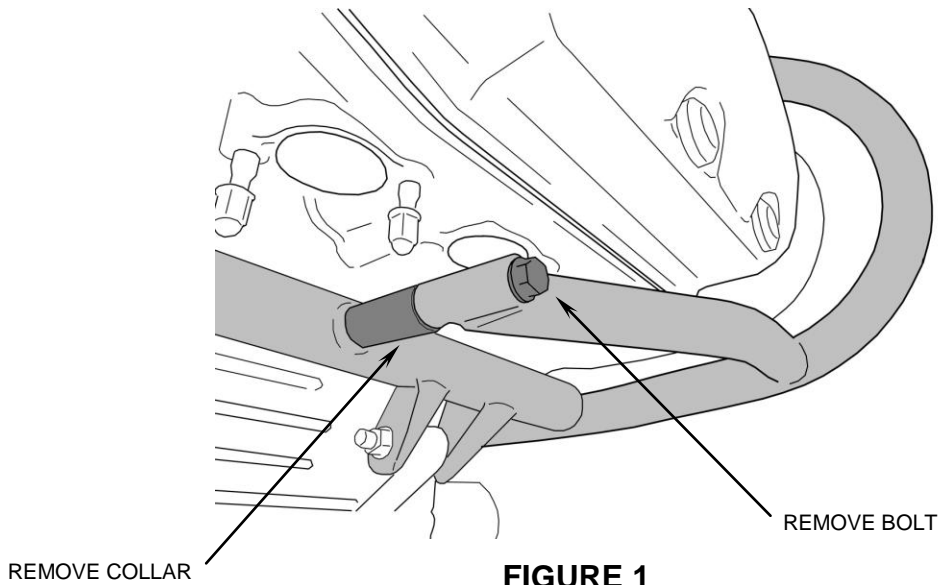

FIGURE 1
RIGHT SIDE SHOWN
(STOCK EXHAUST REMOVED FOR CLARITY)

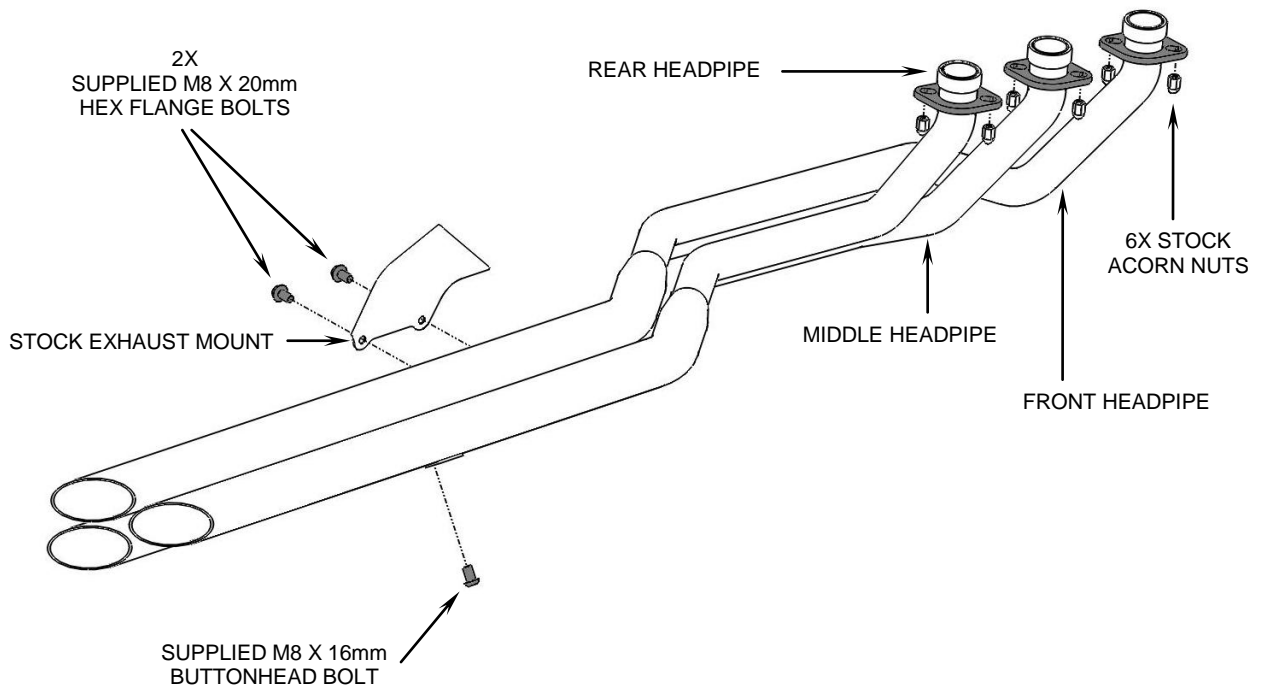

FIGURE 2
RIGHT SIDE SHOWN