

COBRA

Items Supplied >

- 1 – FREEWAY BAR
- 2 – BLACK SPACERS
- 4 – M10 X 30mm ALLEN BOLT
- 2 – MACHINED CLAMPS
- 4 – 5/16" BUTTON HEAD BOLTS
- 4 – 5/16" FLAT WASHERS
- 2 – M6x16mm HEX BOLTS
- 1 – CHARCOAL CANISTER MOUNT

Application >

YAMAHA ROADSTAR1600/1700

99-14

Instruction Manual >

01-1251 / 01-2251

Read all directions carefully before installing your Cobra® freeway bar

1. Remove the right floorboard mount. Install one (1) spacer at the rear hole between the floorboard mount and the frame using the supplied 10mm Allen bolt. **DO NOT TIGHTEN.**
2. Repeat step 1 on left side.

NOTE: If your bike has a charcoal canister;

Remove the (2) M6 bolts from the charcoal canister and discard. Remove the (2) M6 bolts from the charcoal canister mount and floorboard mount and discard mount and bolts. Install the supplied Cobra charcoal canister mount to the charcoal canister by inserting the (2) supplied M6 flange bolts. **DO NOT TIGHTEN.** Remove the (2) M6 bolts from the horn mount and frame. Re-insert bolts thru horn mount, charcoal canister mount and into the frame. (See Figure 1). Tighten all (4) M6 bolts. Torque bolts to factory specifications.

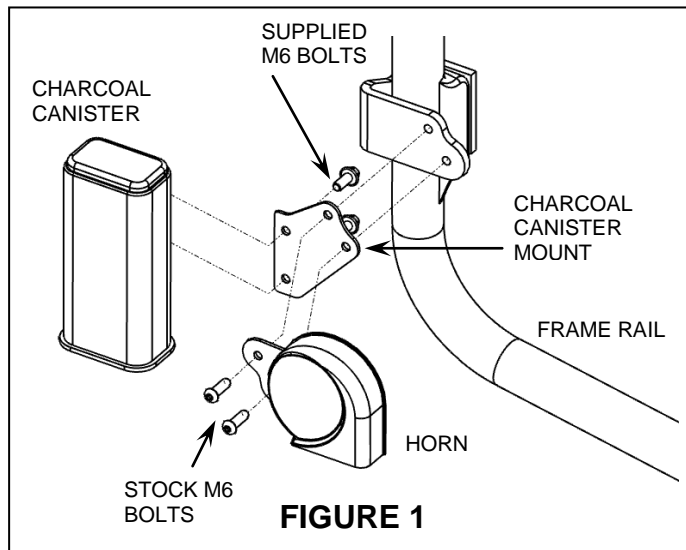

3. Position the freeway bar by placing the lower brackets between the floorboard mounts and frame. Mount the lower brackets using the supplied 10mm Allen bolts. **DO NOT TIGHTEN.**
4. Pull the top of the freeway bar to the frame and secure using the supplied clamps, 5/16" bolts, and washers. The clamps will go behind frame tubes & the bracket will rest against the front of frame tube with the button head bolts facing forward. **Note:** Clamps may not be positioned on upper bracket properly when removing from box; they are placed on bracket for shipping purposes only.
5. Torque all hardware to factory torque specifications.
6. Check to make sure all hardware is tight and everything is in good working order before riding.

Cobra Freeway Bars add style to your motorcycle. They are not designed to withstand a serious impact and may not protect you and/or your motorcycle in the event of a crash.

*** Cobra® recommends you always wear a helmet while riding. Please never operate your motorcycle while under the influence of alcohol and/or drugs. Enjoy the new look of your motorcycle and please ride safely.**

Anything's Possible.®