

COBRA

Items Supplied >

1. 1 – PLATED FREEWAY BAR ASSEMBLY
2. 1 – CHARCOAL CANISTER RELOCATOR
3. 1 – MASTER CYLINDER SPACER, BLACK
4. 2 – BOLT, FLANGED HEX M8 X 16 mm LOC. PATCH
5. 3 – BOLT, FLANGED HEX M10-1.25 X 35 mm
6. 1 – BOLT, BUTTONHEAD M6 X 10 mm ZINC
7. 2 – BOLT, BUTTONHEAD M8 X 25 mm STAINLESS

Application(s) >

YAMAHA V-STAR 1300/TOURER 07-14

Instruction Manual >

01-1245 / 01-2245

Page 1 of 2

Read all instructions carefully before installing your new Cobra product!

1. Remove the (2) M10 bolts from the right floorboard mount at frame and discard. Remove the **front** M10 bolt from the **left** side floorboard and discard.
 - 1a. If your motorcycle has a charcoal canister you need to remove the (2) M6 bolts that hold the canister to the mount. Install charcoal canister relocator bracket onto the stock mount with (1) of the M6 bolts removed earlier in this step. Insert the second M6 bolt through the relocator bracket's middle hole and into canister. Insert the supplied M6 X 10 mm buttonhead bolt into the top-mounting hole and into canister and tighten assembly, see Figure 1.

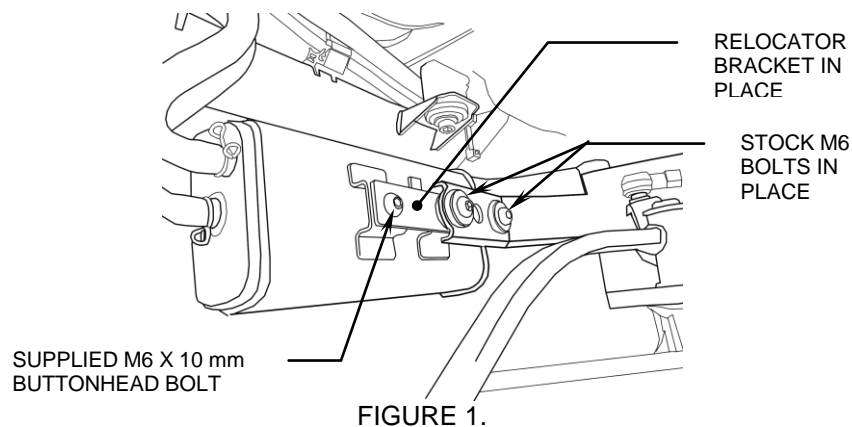

2. Slide the new Cobra freeway bar between frame and front fender with the lower mount brackets facing to the rear. On the **right** side insert (2) supplied M10-1.25 x 35 mm bolts through floorboard mount, then freeway bar mount and into frame, see Figure 2. On the **left** side insert supplied M10-1.25 x 35 mm bolt through freeway bar mount, floorboard mount and into frame, see Figure 3
3. Insert the (2) supplied M8 x 16 mm **flange** bolts through the top (2) holes in motorcycle frame from the inside, (engine side), outward and into the upper freeway bar mount, see Figure 4. You will need to use a universal (wobbly) extension with a 12 mm socket to tighten the (2) M8 bolts at this time.

* **Cobra® recommends you always wear a helmet while riding. Please never operate your motorcycle while under the influence of alcohol and/or drugs. Enjoy the new look of your motorcycle and please ride safely.**

Anything's Possible®

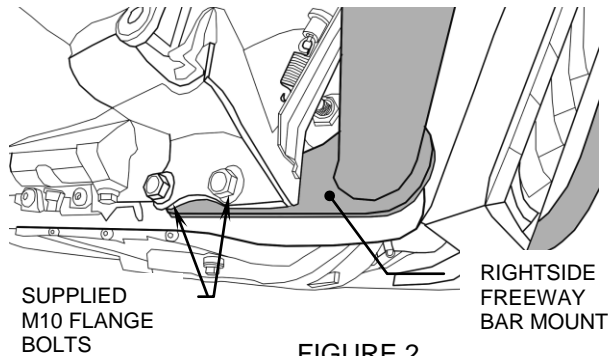

FIGURE 2.

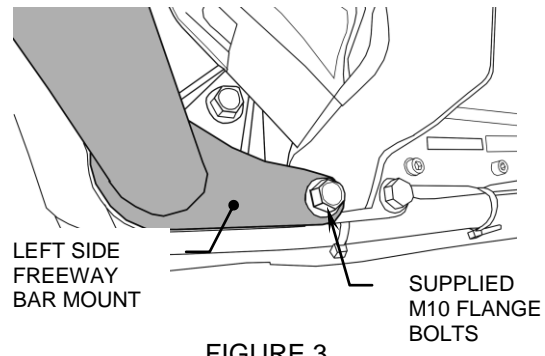

FIGURE 3.

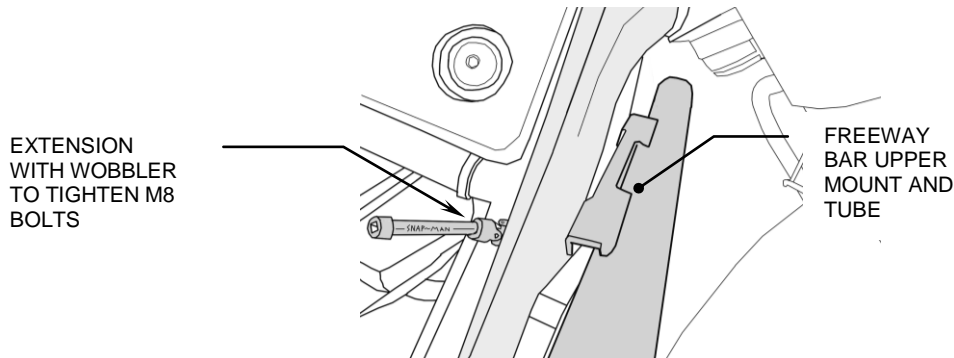

FIGURE 4.

4. Remove the (2) M8 bolts from the rear master cylinder on the right side of the motorcycle and discard. Place the provided black spacer between master cylinder and frame and insert the (2) supplied M8 x 25 mm buttonhead bolts through assembly and into frame and tighten, see Figure 5.
5. Tighten the (2) M10 bolts on the **right** side lower freeway bar / floorboard mount and **left** side M10 bolt in the same manner. Torque all bolts to their appropriate factory torque values.

NOTE:

* Before riding vehicle make sure rear brake operates properly *

ATTENTION:

Cobra Freeway Bars add style to your motorcycle. They are not designed to withstand a serious impact and may not protect you and/or your motorcycle in the event of a crash.

MASTERCYLINDER SPACER BETWEEN MASTER CYLINDER AND FRAME FLANGES

SUPPLIED M8 X 25 mm BUTTONHEAD SOCKET BOLTS

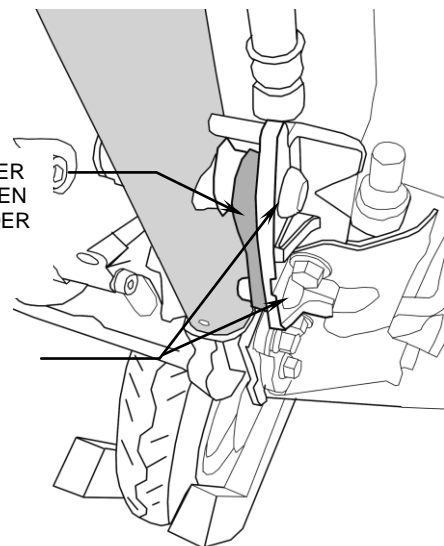

FIGURE 5.