

# COBRA

## Items Supplied >

- 1 - Freeway Bar
- 1 - Spacer Bracket For Master Cylinder
- 1 - Short Round Spacer
- 2 - M8 x 25mm Button Head Bolts

## Application >

V-STAR 1100 99-09

## Instruction Manual >

01-1240

Page 1 of 1

**\* Read all instructions carefully and completely before installing your new Cobra freeway bar \***

1. Unbolt the front bolt only from left side rider foot peg/floorboard bracket and set aside for future assembling.
2. Unbolt the right side rider foot peg/floorboard bracket and set the bolts aside for future assembling. Unbolt the rear brake master cylinder assembly from the frame; the bolts for rear brake master cylinder will be replaced with 8mm X 25mm button heads (supplied).
3. Find the two (2) front bolts for the motor mount; this is where the top freeway bar bracket will mount on both sides. Remove the stock bolts and save.
4. Install the supplied spacer bracket between the rear brake master cylinder assembly and the bottom frame rail using the two (2) supplied M8 x 25mm Button Head Bolts (see figure 1).
5. Install the single short spacer between the rear hole on the foot peg/floorboard bracket and the bottom frame rail using the stock bolt. There will be a gap between front hole and frame that the freeway bar bracket will fill in next step. **FINGER TIGHTEN ONLY.**
6. Install the freeway bar by placing the lower right bracket between the right foot peg/floorboard bracket and the frame using the stock bolt. Then, place the left freeway bar bracket on top of the left foot peg/floorboard bracket using the stock bolt.
7. Install top of the freeway bar using the previously removed stock bolts mentioned in step 3.
8. Tighten all hardware to factory torque specifications (pay special attention to rear brake master cylinder).

**\* Before riding vehicle make sure rear brake operates properly \***

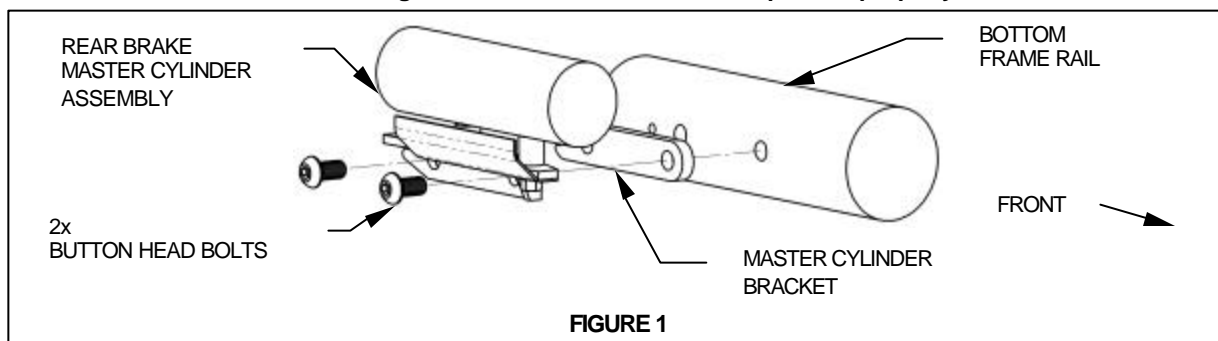

**Cobra Freeway Bars add style to your motorcycle. They are not designed to withstand a serious impact and may not protect you and/or your motorcycle in the event of a crash.**

**\* Cobra recommends you always wear a helmet while riding. Please never operate your motorcycle while under the influence of alcohol and/or drugs. Enjoy the new look of your motorcycle and please ride safely.**

**Anything's Possible.**