



PERFORMANCE 2020

EXHAUSTS &
ACCESSORIES





SHHH. THAT'S THE SOUND OF OUR COMPETITOR'S TEETH CHATTERING.

Maybe you haven't heard of the Cobra Brand. But if you take to the road on the weekends, hit a few rallies, or stop by your local watering hole on a Sunday, you've heard the distinctive Cobra exhaust note.

Whenever an approaching rumble makes other riders perk up their ears and nod in approval, you'll know a Cobra exhaust is in the area. And if you're ever in doubt just ask an experienced rider. They'll tell you, "Yep, that's a Cobra. Sounds like a Neighbor Hater to me!"



LIKES:

Gardening, classical music, and cooking

DISLIKES:

Dogs, modern “music” and **you**



DISTURBING THE PEACE AND THE STATUS QUO SINCE 1977.

WARNING: The mood of the neighborhood is about to change dramatically. Your interest in the Neighbor Hater Mufflers shows you possess an eye for quality and a refreshing lack of restraint. Which means you will likely fire up your new pipes when they sound their best: early in the morning, and during the reverie of soft twilight. Soon after your neighbors will gather and begin to talk. The subject will be you, your motorcycle, and the wonderful sounds produced by your new pipes. *Don't say we didn't warn you.*

THE COBRA ADVANTAGE

We start out every day to make the perfect exhaust. And we come darned close. It helps that we use state-of-the-art lasers to cut our steel and aluminum, and that we make use of the latest generation robotic welders to ensure perfectly welded pieces. But we also use an incredibly talented team of craftsmen and craftswomen to ensure a personal, human touch remains at the heart of every product that ships out to you. And that goes to our fundamental advantage over everyone else. We balance the machine's precision with the artist's imagination. Oh, that and the simple fact we make the best looking, sounding and performing products available.

We can control our quality and costs from start to finish, because we make all our products right here in the red, white, and blue U.S.A.

That's why we offer the only Lifetime Warranty in the business.

That's the Cobra Advantage.

MADE IN THE
USA
ENOUGH SAID

BAGGER HEAD PIPES

MILWAUKEE EIGHT™ HEAD PIPES

- Exhaust head pipes must evolve along with the top end of the motorcycle's engine if they are to be efficient, make power and emit less heat than a stock system.
- For the Milwaukee Eight motor, we modified our famous Cobra PowerPort by enlarging it to become a pulse chamber that accelerates exhaust scavenging to produce the kind of power riders expect.
- The round shape, bulging from between the heat shields gives a clue to the real power potential it offers.
- Offered in a dual-bung option.**
- NOTE: Stock H-D mufflers will not work with this head pipe because of the stock muffler's internal construction. Most aftermarket mufflers will fit.**

6255	Bagger 17-20
6255RB	Bagger 17-20 (Black)

DUAL BUNGS	
6255DB	Bagger 17-20
6255DBRB	Bagger 17-20



DISCLAIMER: NOT LEGAL FOR SALE OR USE IN CALIFORNIA ON ANY POLLUTION CONTROLLED MOTOR VEHICLE.
THE SALE, USE, OR INSTALLATION OF THIS PRODUCT MAY ALSO BE ILLEGAL NATIONWIDE UNDER THE FEDERAL CLEAN AIR ACT (42 U.S.C. § 7522(A)(3)).



POWERPORT DUAL HEADPIPES	
6252	Bagger 2009
6252RB	Bagger 2009 (Black)
6253	Bagger 10-16
DUAL BUNGS	
6253DB1	Bagger 09-16
6253DBRB1	Bagger 09-16 (Black)



TRUE DUAL HEADPIPES	
6250	Bagger 95-06
6250RB	Bagger 95-06 (Black)
6251	Bagger 07-08
6251RB	Bagger 07-08 (Black)
6257	Bagger 17-20
6257RB	Bagger 17-20 (Black)



POWERPORT DUAL HEAD PIPES

- The PowerPort Dual Head Pipes make use of our strategically located PowerPort cross over to deliver 2-into-1 power with the look of a traditional dual system.
- The head pipes fatten the low-end and mid-range torque curve perfect for touring and highway use.
- The system consists of the head pipes, PowerPort cross under section, heat shields and all of the mounting hardware needed.
- It does not include mufflers.**

TRUE DUAL HEAD PIPES

- Our 6250 and 6251 True Dual head pipes for 2008 and earlier Baggers, and now our 6257 system for the 2017 and later baggers feature one-piece, full length, 2.5-inch-diameter heat shields that cover the exhaust pipes from the ports to the chromed muffler bodies.
- We designed these pipes to deliver optimal torque and power while increasing the stock bike's rideability.
- The system consists of head pipes and heat shields and all the mounting hardware required.
- It does not include mufflers.
- The 6250 and 6251 head pipes' 1.75-inch diameter ensures the stock mufflers and most aftermarket mufflers will fit.
- The 6257 head pipes for 2017 and newer engines feature the 2.5-inch diameter right side pipe, requiring mufflers designed for the M 8 Baggers.
- The 6251 and 6257 systems are equipped with oxygen sensor bungs.

DISCLAIMER: NOT LEGAL FOR SALE OR USE IN CALIFORNIA ON ANY POLLUTION CONTROLLED MOTOR VEHICLE.
THE SALE, USE, OR INSTALLATION OF THIS PRODUCT MAY ALSO BE ILLEGAL NATIONWIDE UNDER THE FEDERAL CLEAN AIR ACT (42 U.S.C. § 7522(A)(3)).

BAGGER 4.5" SLIP-ONS

- Our 4.5-inch muffler family shares similar internals such as the 3-inch stepped perforated cores wrapped in a specially constructed fiberglass pillow.
- The perforations and the density of the pillow work to cancel competing sound waves.
- It eliminates mid-range distortion giving the deep, booming bass notes a clear exit stream.
- What you hear is that pleasing, rumbling exhaust note that screams American V-Twin.

RACE PROS

The Race Pros' distinctive black clamshell style clamp is just one thing that sets this muffler apart from all others. It's matched by the black tip held in place with seven, zinc-plated 12-point bolts. Its 4-inch muffler body bells out to 4.5-inches at the rear. It's matched by the black tip held in place with seven, zinc-plated 12-point bolts. Its 4-inch muffler body bells out to 4.5-inches at the rear.

6218**	Bagger 95-16
6216*	Bagger 17-20

BLACK-ON-BLACK

6218RB**	Bagger 95-16
6216RB*	Bagger 17-20

*Qualified manufacturer declared U.S. 50-State legal emissions replacement part on all 2017-2020 Harley-Davidson FL touring models.

**Qualified Manufacturer Declared Emissions Replacement Part on the Harley-Davidson FL touring models listed: California FL touring Models: Fuel Injected 1995-2003, 2007, and 2009-2016; CVO 2000-2003, and 2009-2016. 49 State FL touring models: Carbureted 1995-2005; Fuel Injected 1995-2005, and 2007-2016; CVO 2000-2005, and 2009-2016.



POWR-FLO 4.5-INCH MUFFLERS WITH RACE PRO TIP

6265**	Bagger 95-16
--------	--------------



TRI-FLO

The Tri-Flo muffler morphs from a 4-inch round front to its distinctive triangular form at the rear. A unique thin-line aluminum tip caps it off. It uses the same inner workings as the other 4.5-inch mufflers from Cobra.

TRI-FLO MUFFLERS

6212**	Bagger 95-16
6212CB**	Bagger 95-16 (Black Tip)
6212RB**	Bagger 95-16 (Black)

POWER-FLO

The Power-Flo's 4-inch diameter muffler front expands smoothly toward the rear to reach a 4.5-inch diameter, that is capped by a thin-line, beveled aluminum tip. The Power-Flo muffler is also available with the black Race Pro style tip and its seven, zinc-plated 12-point bolts.

POWER-FLO 4.5-INCH MUFFLERS

6214*	Bagger 17-20
6214RB*	Bagger 17-20 (Black)
6215**	Bagger 95-16
6215RB**	Bagger 95-16 (Black)

*Qualified manufacturer declared U.S. 50-State legal emissions replacement part on all 2017-2020 Harley-Davidson FL touring models.

**Qualified Manufacturer Declared Emissions Replacement Part on the Harley-Davidson FL touring models listed: California FL touring Models: Fuel Injected 1995-2003, 2007, and 2009-2016; CVO 2000-2003, and 2009-2016. 49 State FL touring models: Carbureted 1995-2005; Fuel Injected 1995-2005, and 2007-2016; CVO 2000-2005, and 2009-2016.



DISCLAIMER: NOT LEGAL FOR SALE OR USE IN CALIFORNIA ON ANY POLLUTION CONTROLLED MOTOR VEHICLE.
THE SALE, USE, OR INSTALLATION OF THIS PRODUCT MAY ALSO BE ILLEGAL NATIONWIDE UNDER THE FEDERAL CLEAN AIR ACT (42 U.S.C. § 7522(A)(3)).

DISCLAIMER: NOT LEGAL FOR SALE OR USE IN CALIFORNIA ON ANY POLLUTION CONTROLLED MOTOR VEHICLE.
THE SALE, USE, OR INSTALLATION OF THIS PRODUCT MAY ALSO BE ILLEGAL NATIONWIDE UNDER THE FEDERAL CLEAN AIR ACT (42 U.S.C. § 7522(A)(3)).

BAGGER 4" SLIP-ONS

NEIGHBOR HATER MUFFLERS

- Destined for V-Twin glory The Cobra's Neighbor Hater mufflers boast a soul-lifting boom.
- We offer these in two versions for the Baggers: The first uses 4-inch bodies that bell out to 4.5-inches at the rear which features a smooth rolled end.
- That shape adds a megaphone enhancement to the sound, and the mechanical core exits in a trumpet-bell shape that allows the V-Twin sound track to flow at full song.
- The second version of our NH muffler is our 4-inch with beautifully machined aluminum tips which feature dual cuts finished in black with machined alluvial flutes.
- It's a muffler for the rider who thinks, too loud, is just right.

NEIGHBOR HATER MUFFLERS

6107**	Bagger 95-16
6107RB**	Bagger 95-16 (Black)
6109*	Bagger 17-20
6109RB*	Bagger 17-20 (Black)
6266**	Dual Cut Tip Bagger 95-16
6266RB**	Dual Cut Tip Bagger 95-16 (Black)
6267*	Dual Cut Tip Bagger 17-20
6267RB*	Dual Cut Tip Bagger 17-20 (Black)

Note: For Milwaukee Eight engines the NH, Dual Cut, 909, 909 Uppercut all use the Neighbor Hater core.

*Qualified manufacturer declared U.S. 50-State legal emissions replacement part on all 2017-2020 Harley-Davidson FL touring models.

**Qualified Manufacturer Declared Emissions Replacement Part on the Harley-Davidson FL touring models listed: California FL touring Models: Fuel Injected 1995-2003, 2007, and 2009-2016; CVO 2000-2003, and 2009-2016. 49 State FL touring models: Carbureted 1995-2005; Fuel Injected 1995-2005, and 2007-2016; CVO 2000-2005, and 2009-2016.



909 MUFFLERS

- These 4-inch round mufflers are unique on several fronts.
- First, the rear is finished with a rolled scalloped tip, not a simple slash cut.
- That rolled tip is matched with an inner core finished with the same scalloped cut.
- The inner tip is actually part of the constant velocity, tuned core that gives the muffler its great sound and performance.
- Also, there are no unsightly external screws holding in the tip or core giving the muffler a smooth undisturbed finish from front to back.
- Available in two versions, the original with the scalloped tip and in a new Uppercut version.
- The 909 Uppercut version matches the line of the stock bags.
- The 909 UC uses a stainless-steel tip to help prevent rusting.

6106**	Bagger 95-16
6106RB**	Bagger 95-16 (Black)
6108*	Bagger 17-20
6108RB*	Bagger 17-20 (Black)
6302***	Freewheeler 15-16
6303***	Tri-Glide 09-16

UPPERCUT MUFFLERS

6268**	Bagger 95-16
6268B**	Bagger 95-16 (Black)
6269*	Bagger 17-20
6269B*	Bagger 17-20 (Black)

*Qualified manufacturer declared U.S. 50-State legal emissions replacement part on all 2017-2020 Harley-Davidson FL touring models.

**Qualified Manufacturer Declared Emissions Replacement Part on the Harley-Davidson FL touring models listed: California FL touring Models: Fuel Injected 1995-2003, 2007, and 2009-2016; CVO 2000-2003, and 2009-2016. 49 State FL touring models: Carbureted 1995-2005; Fuel Injected 1995-2005, and 2007-2016; CVO 2000-2005, and 2009-2016.

***Qualified manufacturer declared U.S. 50-State legal emissions replacement part on all 2009-2020 Harley-Davidson Tri-Glide models and 2015-2020 Freewheeler models.

DISCLAIMER: NOT LEGAL FOR SALE OR USE IN CALIFORNIA ON ANY POLLUTION CONTROLLED MOTOR VEHICLE.
THE SALE, USE, OR INSTALLATION OF THIS PRODUCT MAY ALSO BE ILLEGAL NATIONWIDE UNDER THE FEDERAL CLEAN AIR ACT (42 U.S.C. § 7522(A)(3)).



DISCLAIMER: NOT LEGAL FOR SALE OR USE IN CALIFORNIA ON ANY POLLUTION CONTROLLED MOTOR VEHICLE.
THE SALE, USE, OR INSTALLATION OF THIS PRODUCT MAY ALSO BE ILLEGAL NATIONWIDE UNDER THE FEDERAL CLEAN AIR ACT (42 U.S.C. § 7522(A)(3)).

EL DIABLO SLIP-ON

With our El Diablo Slip-on, we've brought back a megaphone muffler, but updated and restyled for these modern times. These have the classic megaphone shape capped with a large machined aluminum tip that has our Cobra logo engraved on top. They deliver a deep sonic thump thanks to its louvered cores that keeps that powerful V-Twin rhythm going for miles and miles. It's available in chrome or black.

NOTE* When this muffler is used with the Cobra head pipe it requires the use of this optional tapered heat shield. This heat shield is not required with the stock M8 head pipe.



6206	Bagger 95-16
6206RB	Bagger 95-16 (Black)
6208	Bagger 17-20
6208RB	Bagger 17-20 (Black)
6208HS*	Chrome Heat Shield
6208HSB*	Black Heat Shield

*Needed when mounting with our 6255 series head pipes on a 17-20 Bagger

TRI OVAL II

With its louvered core that branches to fit the dual outlets on the machined tip, the Tri Oval II has a look that matches its great sound. The 4-inch round muffler body morphs into its oval shape at the rear where a beautifully scalloped tip with machined alluvial flutes creates a jewel-like finish.

6219	Bagger 95-16
------	--------------



4-INCH MUFFLERS WITH RACE PRO TIP

6264	Bagger 95-16
6263	Bagger 17-20



3-INCH MUFFLERS WITH RACE PRO TIP

6070	Bagger 95-16
6070RB	Bagger 95-16 (Black)
6071*	Bagger 17-20
6071RB*	Bagger 17-20 (Black)



4-INCH MUFFLERS

The 4-inch muffler body is the gold standard for H-D Bagger models. It's the nearly perfect size for style, sound and performance. Both versions here use the same internal construction so they will sound the same. The differences are in the tips: a straight cut, machined tip, or a scalloped tip that can be bolted in one of three positions.

FOUR-INCH SLIP-ON MUFFLERS

6204	Scalloped Tip Bagger 95-16
------	----------------------------

3-INCH MUFFLERS

These 3-inch slip-on mufflers (in our slash cut aluminum tip or in the RPT (Race Pro Tip) versions offer performance and style without breaking the bank. The 2-inch core, surrounded with a special e-glass packing and a stainless-steel mesh screen, offers the best performance and sound quality available in a 3-inch diameter muffler body. The standard 3-inch bodies include aluminum slash-cut tips, and the tips can be mounted in one of three positions. The RPT bodies begin at 3-inches up front and expand to 3.5-inches at the rear. On the black bodies the tip is clear coated, machined aluminum, while the chrome version offers a black tip.

THREE-INCH SLIP-ON MUFFLERS

6020	Bagger 95-16
6021*	Bagger 17-20
6021RB*	Bagger 17-20 (Black)

REPLACEMENT CORES - 2"

9025	Fits Cobra part #6020
------	-----------------------

REPLACEMENT CORES - 1-3/4"

9028	Fits Cobra part #6020
------	-----------------------

*Qualified manufacturer declared U.S. 50-State legal emissions replacement part on all 2017-2020 Harley-Davidson FL touring models.

DISCLAIMER: NOT LEGAL FOR SALE OR USE IN CALIFORNIA ON ANY POLLUTION CONTROLLED MOTOR VEHICLE.

THE SALE, USE, OR INSTALLATION OF THIS PRODUCT MAY ALSO BE ILLEGAL NATIONWIDE UNDER THE FEDERAL CLEAN AIR ACT (42 U.S.C. § 7522(A)(3)).

DISCLAIMER: NOT LEGAL FOR SALE OR USE IN CALIFORNIA ON ANY POLLUTION CONTROLLED MOTOR VEHICLE.

THE SALE, USE, OR INSTALLATION OF THIS PRODUCT MAY ALSO BE ILLEGAL NATIONWIDE UNDER THE FEDERAL CLEAN AIR ACT (42 U.S.C. § 7522(A)(3)).

BAGGER

2-INTO-1 SYSTEMS

TURNOUT 2-INTO-1 EXHAUST

Our headpipe merges into a large 2.25-inch collector that steps up to a 2.5-inch core. We perforated the core and wrapped it in a stainless steel screen then enclosed it in a fiberglass pillow to get the performance and sound we wanted.

We then covered the collector with a large one-piece heat shield that is held in place with two clamps and stamped the Cobra logo on it as well. We used a 4-inch muffler body capped with a 4-inch machined aluminum dual-cut tip that features small alluvial flutes. The body can be rotated 10-degrees up from its stock setting allowing the rider to determine the final placement. And it works with either stock or extended bags.

Available in chrome or black, both with a black tip.

TURNOUT 2-INTO-1 EXHAUST

6270	Bagger 09-16
6270B	Bagger 09-16 (Black)
6271	Bagger 17-20
6271B	Bagger 17-20 (Black)



POWR-FLO 2-INTO-1 EXHAUST (EL DIABLO TIP)

6451	Bagger 17-20
6451RB	Bagger 17-20 (Black)



POWR-FLO 2-INTO-1 EXHAUST (RPT TIP)

6450	Bagger 09-16
6450B	Bagger 09-16 (Black)

HP POWER PRO 2-INTO-1 EXHAUST

6430	*Bagger 95-06
6431	*Bagger 07-08

*Pipes extend to end of saddlebags.



BAGGER

2-INTO-1 SYSTEMS

POWERFLO EL DIABLO 2-INTO-1 EXHAUST

- Our 2-into-1 for the Milwaukee Eight engine uses a 2.5-inch collector, which creates big horsepower and torque.
- The muffler uses a PowrFlo 4.5-inch shell, with a 3-inch stepped baffle wrapped with a sealed pillow of sound absorbing material which provides a deep rumble.
- The rear is finished off with our El Diablo style billet tip, which is powder coated in black and etched with the Cobra logo.
- COMES WITH DUAL BUNGS

POWERFLO 2-INTO-1 EXHAUST

- This 2-into-1 exhaust from Cobra uses 1.75-inch head pipes which step up to the 2-inch inlet into the muffler.
- Its 4.5-inch PowerFlo muffler produces a deep, throaty note because of the partnership of the 3-inch stepped core and proprietary sound tuning materials that surround the core.
- The 4.5-inch Race Pro tip is finished in satin black, held in place with seven, 12-point zinc plated bolts.
- COMES WITH DUAL BUNGS

HP POWER PRO 2-INTO-1 EXHAUST

- Bagger and horsepower are not mutually exclusive terms, and in fact when you are looking to get the most performance out of your Bagger's engine, look no further than this HP Power Pro 2-into-1.
- It performs at the top of its class in terms of performance, and it also delivers a bump in torque.
- The muffler is capped with a machined aluminum tip that gives the system its polished finish.

BAGGER SPEEDSTER

SPEEDSTER DUALS WITH FISHTAIL TIPS

6974 Bagger 10-16
6975 Bagger 17-20



SPEEDSTER DUALS EXHAUST

This system combines the PowerPort Duals head pipe design and the famous Cobra Speedster blueprint for a sleek dual style with an extra kick. Full-length, 2.5-inch, single heat shields give a full seamless appearance. Straight-cut, chromed billet tips finish off the pipes. **Now available with Fishtail tips.**

SPEEDSTER LONG EXHAUST

The Cobra Speedster Longs balance out the longer look of today's Cruisers. Full-length, 2.5-inch-diameter heat shields wrap 222° around the exhaust pipe beginning at the cylinder heads before flowing down to the end of the pipe where they are capped off with machined and chromed billet tips.



SPEEDSTER SHORT SWEPT EXHAUST

The Cobra Speedster exhaust is our top-of-the-line system, here seen in our Short Swept version. Speedsters display a classic 2-into-2 style, while offering uncommon beauty and superior performance. Full-length 2.5-inch diameter heat shields wrap 222° around the exhaust pipe beginning at the exhaust ports and flowing down to the end of the pipe. It's a stylish system that also uncorks the stock bike's sound and performance.



SPEEDSTER LONG EXHAUST

6961T *Bagger 07-08

*Pipes extend to end of saddlebags.

SPEEDSTER SHORT SWEPT EXHAUST

6230 Bagger 10-16
6230B Bagger 10-16 (Black)
6231 Bagger 17-20
6231B Bagger 17-20 (Black)

SPEEDSTER DUALS EXHAUST

6973 Bagger 10-16
6973B Bagger 10-16 (Black)

IRONICALLY, OUR
CUSTOMERS TEND
TO BE QUIET AND
SOFT-SPOKEN.

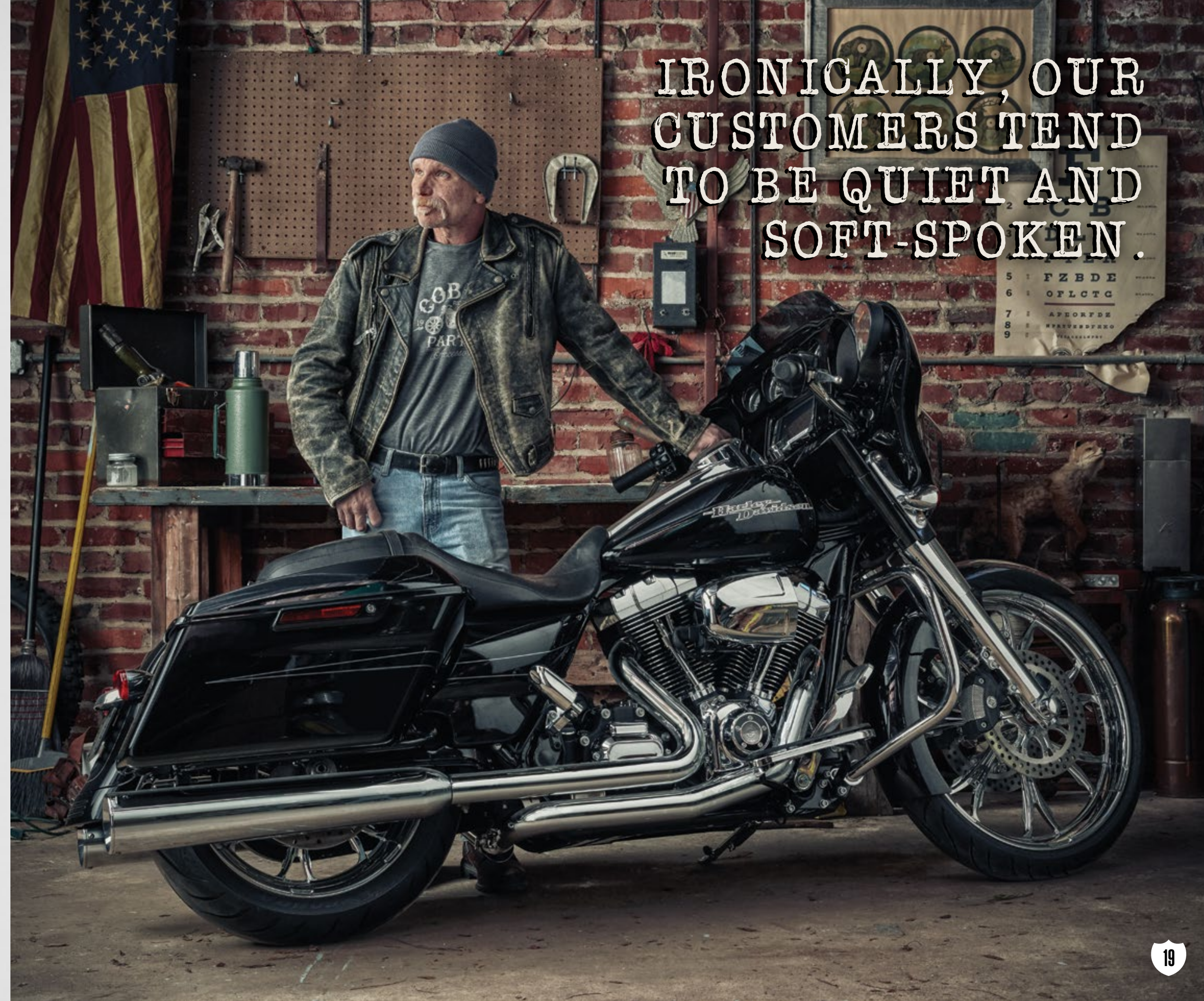

DISCLAIMER: NOT LEGAL FOR SALE OR USE IN CALIFORNIA ON ANY POLLUTION CONTROLLED MOTOR VEHICLE.
THE SALE, USE, OR INSTALLATION OF THIS PRODUCT MAY ALSO BE ILLEGAL NATIONWIDE UNDER THE FEDERAL CLEAN AIR ACT (42 U.S.C. § 7522(A)(3)).

TRIKE EXHAUST

909 SLIP-ONS

- The 4-inch diameter, 909-Twins feature a unique scalloped and smooth rolled outer tip that is matched with a scalloped inner tip.
- This twin-tip design gives an elegant look, because there are no visible outer screws securing the core.
- We use a 2.25-inch louvered core for its traditional and recognizable Harley sound.

FREEWHEELER MUFFLERS

- These slip-on mufflers were designed specifically for the new Harley-Davidson Freewheeler model.
- In fact, the Freewheeler specific fitment has approximately the same end point as the stock mufflers.
- When used with the stock head pipes, the mufflers are a simple bolt on installation.
- We built chromed 3.75-inch muffler bodies that bell out at the end to four inches.
- They are capped off with black powder-coated, machined aluminum race pro tips.
- The internal construction of the muffler bodies consists of 2.5-inch perforated cores, wrapped in woven fiberglass that is protected by a fiberglass wrap.



909 SLIP-ONS

6302* Freewheeler 15-20
6303* Tri Glide 09-20

*Qualified manufacturer declared U.S. 50-State legal emissions replacement part on all 2009-2016 Harley-Davidson Tri-Glide models and 2015-2016 Freewheeler models.

FREEWHEELER MUFFLERS

6300 Freewheeler 15-20



TRI GLIDE MUFFLERS

- Designed specifically for Harley's big trike, the Cobra mufflers use 3.75-inch muffler bodies capped off with machined 3-inch, radial slash cut aluminum tips that step up to the bodies via a mild yet graceful double bevel.
- This configuration allows the Cobra tips to have the ground clearance equal to or in sometimes greater than the stock system.
- The internal construction of the muffler bodies consists of a 2.25-inch perforated constant velocity core, that is protected by a fiberglass wrap.
- This provides outstanding performance with a deep thundering bass note. Available in chrome with chromed aluminum tips.

6301 Tri Glide 09-20

TRIKE HEAD PIPES

- Designed specifically for HD trike models, these head pipes are a direct bolt on for both Freewheeler, and Tri Glide models.
- They have the "S" bends built into the pipe, eliminating the need for aftermarket adapters.
- Fitments for the Twin Cam Baggers (2009-2016) as well as for the newer Milwaukee Eight motors.
- Because of the Cobra® PowerPort crossover this system performs like a true 2-into-1 pipe with the clean look of a traditional dual system.
- The PowerPort Dual head pipes fatten the low end and mid-range torque curve, perfect for touring and highway use.
- Includes oxygen sensor bungs.
- NOTE: Fitment of the #6253DB1 Cobra headpipes (or any other non-Cobra aftermarket head pipes) requires Cobra's "S" bend adapter kit, Cobra part #6201T.

6253DB1 Tri Glide 2009
6254 Freewheeler & Tri Glide 10-16
6256 Freewheeler & Tri Glide 17-20

DISCLAIMER: NOT LEGAL FOR SALE OR USE IN CALIFORNIA ON ANY POLLUTION CONTROLLED MOTOR VEHICLE.
THE SALE, USE, OR INSTALLATION OF THIS PRODUCT MAY ALSO BE ILLEGAL NATIONWIDE UNDER THE FEDERAL CLEAN AIR ACT (42 U.S.C. § 7522(A)(3)).

DISCLAIMER: NOT LEGAL FOR SALE OR USE IN CALIFORNIA ON ANY POLLUTION CONTROLLED MOTOR VEHICLE.
THE SALE, USE, OR INSTALLATION OF THIS PRODUCT MAY ALSO BE ILLEGAL NATIONWIDE UNDER THE FEDERAL CLEAN AIR ACT (42 U.S.C. § 7522(A)(3)).



EL DIABLO 2-INTO-1 EXHAUST

One quick and easy way to increase your bike's horsepower is to install one of our 2-into-1 systems. Our latest upswept 2-into-1 for the Softails, Dynas and Sportsters uses equal length headers, mated to a cone megaphone or short 3.5-inch round canister-style muffler.

The 4-inch machined aluminum tip is powder coated black, and etched with the Cobra logo. The tip's reverse cone shape tastefully compliments the upswept muffler. Heat shields cover the exhaust headers and the collector nestles beneath a simple chromed/or black cover.

Available in chrome with black tip or black with black tip, in either the megaphone or canister shaped muffler.

EL DIABLO 2-INTO-1 EXHAUST

- 6471* Sportster 86-03
- 6471B* Sportster 86-03 (Black)
- 6472 Sportster 07-13
- 6472B Sportster 07-13 (Black)
- 6473** Sportster 14-20
- 6473B** Sportster 14-20 (Black)
- 6474 FXFB/S 18-20
- 6474B FXFB/S 18-20 (Black)
- 6475 FLFB/S,FXBR/S,FXDR 18-19
- 6475B FLFB/S,FXBR/S,FXDR 18-19 (Black)
- 6476 Dyna 06-11
- 6476B Dyna 06-11 (Black)
- 6477 Dyna 12-17
- 6477B Dyna 12-17 (Black)
- 6479 FLHC/S,FLSB 18-20
- 6479B FLHC/S,FLSB 18-20 (Black)
- 6483 Softails 12-17
- 6483B Softails 12-17 (Black)
- 6484 Softails 07-11
- 6484B Softails 07-11 (Black)
- 6485 Softails 86-06
- 6485B Softails 86-06 (Black)
- 6478 FXBB, FXLR/S, FLFL, FLDE 18-20
- 6478B FXBB, FXLR/S, FLFL, FLDE 18-20 (Black)

EL DIABLO 3.5 INCH 2-INTO-1 EXHAUST

- 6492 Sportster 07-13
- 6492B Sportster 07-13 (Black)
- 6493** Sportster 14-20
- 6493B** Sportster 14-20 (Black)
- 6496 Dyna 06-11
- 6496B Dyna 06-11 (Black)
- 6497 Dyna 12-17
- 6497B Dyna 12-17 (Black)

*Will not fit models with forward control footpegs
 **Will not fit Superlow



POWER PRO 2-INTO-1 EXHAUST

When you are looking to get the most performance out of your Sporty's or Big-Twin's engine, look no further than this HP Power Pro 2-into-1. It performs at the top of its class in terms of brute power, but it also delivers a noticeable surge in low- and mid-range torque. That surge hits right where you need it the most, when you jump on the throttle to pass that line of motorhomes choking that road to freedom. The news gets even better when you consider the styling, which includes Cobra's unique collector area heat shield that conceals the collector junction. The muffler is capped with a machined aluminum tip that gives the system its polished finish. All that's why this system earns Cobra's Lifetime Warranty.

POWER PRO HP 2-INTO-1 EXHAUST

- 6420 Softail 86-06
- 6421 Softail 07-11
- 6422 Softail 12-17

POWER PRO HP 2-INTO-1 EXHAUST WITH RACE PRO TIP

- 6461* Sportster 07-13
- 6461B* Sportster 07-13 (Black)
- 6468 Dyna 12-17
- 6468B Dyna 12-17 (Black)

*Does not work with forward controls

EL DIABLO 3.5 INCH 2-INTO-1 EXHAUST

SPEEDSTER EXHAUST

The Cobra Speedster exhaust is our top-of-the-line system. Speedsters display a classic 2-into-2 style, while offering uncommon beauty and superior performance. Full-length 2.5-inch diameter heat shields wrap 222° around the exhaust pipe beginning at the exhaust ports and flowing down to the end of the pipe where they are capped off with chromed billet tips on all but the Swept versions. It's a stylish system that also uncorks the stock bike's sound and performance.

That's because the Speedsters offer class-leading performance due in large part to the Cobra PowerPort, an engineering advancement that provides a jump in horsepower and torque over the stock motorcycle.

The PowerPort also improves the overall rideability while remaining discreetly out of sight. And it does that while retaining all the great sound and style you expect from Cobra.

POWERPORT

We designed the PowerPort to provide a significant performance increase similar to what you would expect to gain with a 2-into-1 system. We spent a lot of time in the dyno room with the PowerPort to achieve that power gain and also to improve the overall rideability of the motorcycle. Best of all, the PowerPort works while tucked away almost unseen behind the Speedster's full-length heat shields. We also located the PowerPort in the muffler section that allows for an easier installation because the customer can install the head pipes individually.



SPEEDSTER SHORT RPT

The Speedster Short exhaust with Race Pro Tips (RPT) make use of all of the high-tech features of our regular 2.5-inch Speedster systems. It uses the PowerPort for increased power and uses 1.75-inch constant velocity cores for exceptional sound and performance.

The RPT designation comes from adapting the design from our Race Pro 4-inch muffler into this full system. The 2.5-inch heat shields expand to 2.75-inches at the end. The tips mimic the Race Pro machined design, and are held in place with 12-point bolts. On the black version the tip is clear coated, machined aluminum, while the chrome version offers a black tip.



SPEEDSTER 909 EXHAUST

The 909 Speedsters have the unique blend of performance, sound, style and price. First like all of our Speedsters, these feature the PowerPort cross over which delivers class-leading power. That's a critical feature when you are using such a short system. Then we expand the end and roll the tips to give a brawny look that is matched by the sound. These use the same internal construction as our short RPT system so you also enjoy the same premium sound. And you just can't beat the price. Throw in our limited lifetime warranty and you've got a rock solid system.

- 6701* Sportster 86-03
- 6701B* Sportster 86-03 (Black)
- 6704 Sportster XL 07-13
- 6704B Sportster XL 07-13 (Black)
- 6705** Sportster XL 14-20
- 6705B** Sportster XL 14-20 (Black)
- 6709 Dyna 06-11
- 6709B Dyna 06-11 (Black)
- 6708 Dyna 12-17
- 6708B Dyna 12-17 (Black)
- 6710 Softails 07-11
- 6711 Softails 12-17
- 6711B Softails 12-17 (Black)
- 6712 FXBB, FXLR/S, FLSL, FLDE 18-20
- 6712B FXBB, FXLR/S, FLSL, FLDE 18-20 (Black)
- 6713 FLHC/S, FLSB 18-20
- 6713B FLHC/S, FLSB 18-20 (Black)
- 6714 FXFB/S 18-20
- 6714B FXFB/S 18-20 (Black)
- 6715 FLFB/S, FXBR/S, FXDR 18-20
- 6715B FLFB/S, FXBR/S, FXDR 18-20 (Black)

*Will not fit models with forward control footpegs
 **Will not fit Superlow



DISCLAIMER: NOT LEGAL FOR SALE OR USE IN CALIFORNIA ON ANY POLLUTION CONTROLLED MOTOR VEHICLE. THE SALE, USE, OR INSTALLATION OF THIS PRODUCT MAY ALSO BE ILLEGAL NATIONWIDE UNDER THE FEDERAL CLEAN AIR ACT (42 U.S.C. § 7522(A)(3)).

SPEEDSTER SHORT RPT

The Speedster Short exhaust with Race Pro Tips (RPT) make use of all of the high-tech features of our regular 2.5-inch Speedster systems. It uses the PowerPort for increased power and uses 1.75-inch constant velocity cores for exceptional sound and performance.

The RPT designation comes from adapting the design from our Race Pro 4-inch muffler into this full system. The 2.5-inch heat shields expand to 2.75-inches at the end. The tips mimic the Race Pro machined design, and are held in place with 12-point bolts. On the black version the tip is clear coated, machined aluminum, while the chrome version offers a black tip.

SPEEDSTER SHORT EXHAUST WITH RACE PRO TIP

6784B	Sportster XL 07-13 (Black)
6785*	Sportster XL 14-20
6785B*	Sportster XL 14-20 (Black)
6788	Dyna 12-17
6789	Dyna 06-11
6789B	Dyna 06-11 (Black)
6791	Softails 12-17
6792	FXBB, FXLR/S, FLSL, FLDE 18-20
6792B	FXBB, FXLR/S, FLSL, FLDE 18-20 (Black)
6793	FLHC/S,FLSB 18-20
6793B	FLHC/S,FLSB 18-20 (Black)
6794	FXFB/S 18-20
6794B	FXFB/S 18-20 (Black)
6795	FLFB/S,FXBR/S,FXDR 18-20
6795B	FLFB/S,FXBR/S,FXDR 18-20 (Black)

*Will not fit Superlow



SPEEDSTER SWEPT EXHAUST

The curves on the road are nothing compared to what we're seeing in some of the latest cruisers—and exactly why not just any pipe design will do. Enter the Speedster Swept.

A real work of metallurgical art, the high sweeping lines of these pipes are truly breathtaking. Like our flagship Speedsters, the Swepts also include Cobra's PowerPort, which gives them 2-into-1 power while maintaining the great 2-into-2 look.

These Swept exhausts are then given full-length, triple-layer chrome 2.5-inch heat shields covering 1.75-inch head pipes.

SPEEDSTER SHORT SWEPT EXHAUST

6223*	Softail 86-06
6224*	Softail 07-11
6224B*	Softail 07-11 (Black)
6225*	Softail 12-17
6225B*	Softail 12-17 (Black)
6226*	Softail FXSB 13-17
6226B*	Softail FXSB 13-17 (Black)
6227B	Dyna 06-11 (Black)
6229	Dyna 12-17
6229B	Dyna 12-17 (Black)
6230	Bagger 10-16
6230B	Bagger 10-16 (Black)
6231	Bagger 17-20
6231B	Bagger 17-20 (Black)
6233*	Sportster 14-20
6233B*	Sportster 14-20 (Black)

*The installation of this system requires the removal of the stock right-side passenger foot rest. For riders who need a rear foot rest, we offer an optional passenger peg relocation bracket which permits the stock peg to be reinstalled.

PASSENGER FOOTPEG RELOCATION

606-6220	Softail 86-16
606-6462	Sportster 14-20

DISCLAIMER: NOT LEGAL FOR SALE OR USE IN CALIFORNIA ON ANY POLLUTION CONTROLLED MOTOR VEHICLE. THE SALE, USE, OR INSTALLATION OF THIS PRODUCT MAY ALSO BE ILLEGAL NATIONWIDE UNDER THE FEDERAL CLEAN AIR ACT (42 U.S.C. § 7522(A)(3)).

DISCLAIMER: NOT LEGAL FOR SALE OR USE IN CALIFORNIA ON ANY POLLUTION CONTROLLED MOTOR VEHICLE. THE SALE, USE, OR INSTALLATION OF THIS PRODUCT MAY ALSO BE ILLEGAL NATIONWIDE UNDER THE FEDERAL CLEAN AIR ACT (42 U.S.C. § 7522(A)(3)).

SPEEDSTER

Additional Speedster offerings include our Speedster Short, Speedster Long and our Speedster Slashdown models. Like all other Speedsters they include full-length heatshields as well as the Power Port crossover, which provides a jump in horsepower and torque over the stock motorcycle. The crossover also contributes to the Speedsters' pleasing exhaust note, rounding off the sharp edges of the exhaust sound profile.

SPEEDSTER SLASHDOWN EXHAUST

6850	Softail 86-06
6851	Softail 07-11
6851B	Softail 07-11 (Black)
6852	Softail 12-17
6852B	Softail 12-17 (Black)
6853	FXBB, FXLR/S, FLSL, FLDE 18-20
6853B	FXBB, FXLR/S, FLSL, FLDE 18-20 (Black)
6854	FLHC/S,FLSB 18-20
6854B	FLHC/S,FLSB 18-20 (Black)
6863	FLFB/S,FXBR/S,FXDR 18-20
6863B	FLFB/S,FXBR/S,FXDR 18-20 (Black)
6864	FXFB/S 18-20
6864B	FXFB/S 18-20 (Black)
6855	Dyna 91-05
6857	Dyna 06-11
6858	Dyna/FLD 12-17
6858B	Dyna/FLD 12-17 (Black)
6882	Sportster 883/1200 04-06
6883B	Sportster 883/1200 07-13 (Black)
6883B	Sportster 72 12-13 (Black)

SPEEDSTER X LONG SLASHDOWN EXHAUST

6959	Switchback 12-17
------	------------------

SPEEDSTER LONG EXHAUST

6950T	Softail 86-06
6951T	Softail 07-11
6952T	Softail 12-17
6957T	Dyna 06-11
6961T	*Bagger 07-08

*Pipes extend to end of saddlebags.



DRAGSTER EXHAUST

6810T	Softail 86-06
6811T	Softail 07-11
6815T	Dyna 91-05



3-INCH MUFFLERS

- We offer three 3-inch slip-ons: The Neighbor Hater, The RPT, and the slash-cut tip.
- Each uses a 2-inch constant velocity core for exceptional sound and performance, surrounded by a stainless-steel mesh encased in a bonded e-glass tube.
- The Neighbor Haters have a simple belled rolled end with an inner steel tip.
- On the RPT black version, the tip is clear coated, machined aluminum, while the chrome version offers a black tip.
- The standard 3-inch mufflers use a straight canister with a slash style tip that can be locked in different positions to create the look the rider desires.
- Available in black or chrome.



Two-Inch Constant-Velocity Baffle

We design our baffles to give the absolute best sound and performance. The baffles lock in place at the front slip and bolt to the billet tips at the rear to keep them in place.



Stainless Steel Mesh

This wrap between the louvered baffle and the fiberglass sleeve adds an additional measure of protection for the e-glass sleeve, and prevents the fiberglass packing from burning and blowing out.

High-Density Bonded E-Glass Sleeve

What this means is that you get the sound-reducing qualities of a fiberglass pack that will not blow or burn out in just a few miles.



3-INCH MUFFLERS

SPORTSTER 91-20

Sportsters 04-13 except XL1200V

	Part #
3-Inch Slashcut Chrome	6030
3-Inch Slashcut Black	6030RB
Heatshields Chrome	6030HSRB
RPT Chrome	6080
RPT Black	6080RB
Neighbor Hater Chrome	6085
Neighbor Hater Black	6085RB

Sportsters 14-20

3-Inch Slashcut Chrome	6031
3-Inch Slashcut Black	6031RB
Heatshields Chrome	6031HSRB
RPT Chrome	6081
RPT Black	6081RB
Neighbor Hater Chrome	6086
Neighbor Hater Black	6086B

XL1200V 12-13

3-Inch Slashcut Chrome	6032
3-Inch Slashcut Black	6032B

Sportsters 91-03

Neighbor Hater Chrome	6036
-----------------------	------

REPLACEMENT CORES - 2"

9023 Fits Cobra part # 6030, 6031, 6032, 6055, 6057, 6058, 6080, 6081

REPLACEMENT CORES - 2"

9024 Fits Cobra part # 6000, 6001, 6002, 6003, 6004, 6005, 6006, 6050, 6051, 6052, 6053, 6054, 6056

REPLACEMENT CORES - 1-3/4"

9026 Fits Cobra part # 6030, 6031, 6032, 6055, 6057, 6058, 6080, 6081

REPLACEMENT CORES - 1-3/4"

9027 Fits Cobra part # 6000, 6001, 6002, 6003, 6004, 6005, 6006, 6050, 6051, 6052, 6053, 6054, 6056



DISCLAIMER: NOT LEGAL FOR SALE OR USE IN CALIFORNIA ON ANY POLLUTION CONTROLLED MOTOR VEHICLE. THE SALE, USE, OR INSTALLATION OF THIS PRODUCT MAY ALSO BE ILLEGAL NATIONWIDE UNDER THE FEDERAL CLEAN AIR ACT (42 U.S.C. § 7522(A)(3)).

DISCLAIMER: NOT LEGAL FOR SALE OR USE IN CALIFORNIA ON ANY POLLUTION CONTROLLED MOTOR VEHICLE. THE SALE, USE, OR INSTALLATION OF THIS PRODUCT MAY ALSO BE ILLEGAL NATIONWIDE UNDER THE FEDERAL CLEAN AIR ACT (42 U.S.C. § 7522(A)(3)).

3-INCH MUFFLERS



SOFTAIL 00-20

FLSTF 00-06, FXSTD 00-06

	Part #
3-Inch Slashcut Chrome	6000
3-Inch Slashcut Black	6000B
RPT Chrome	6050
RPT Black	6050B

FLSTF 07-17, FLSTFB 07-17, FXSTD 07-17

3-Inch Slashcut Chrome	6001
RPT Chrome	6051
RPT Black	6051B
Neighbor Hater Chrome	6041
Neighbor Hater Black	6041B

FLSTN 05-17, FLSTSB 08-11, FLS/S 12-17, FLSTFBS 16-17

3-Inch Slashcut Chrome	6002
RPT Chrome	6052
RPT Black	6052B
Neighbor Hater Chrome	6042
Neighbor Hater Black	6042B

FLSTC 07-17, FXCW/FXCWC 07-17, FXSB/FXSBS 07-17, FXST 07-17, FXSTB 07-17, FXSTC 07-17

3-Inch Slashcut Chrome	6003
RPT Chrome	6053
RPT Black	6053B
Neighbor Hater Chrome	6043
Neighbor Hater Black	6043B

FXST 00-06, FXSTB 00-06, FXSTC 00-06, FXSTS 00-06, FLST 00-06, FLSTC 00-06

3-Inch Slashcut Chrome	6004
RPT Chrome	6054
RPT Black	6054B

FXBR/S 18-20, FLSL 18-20, FLFB/S 18-20 FXLR/S 18-20, FSBB 18-20

RPT Chrome	6057
RPT Black	6057B
Neighbor Hater Chrome	6047
Neighbor Hater Black	6047B

FLHC/S 18-20, FLDE 18-20

RPT Chrome	6058
RPT Black	6058B
Neighbor Hater Chrome	6048
Neighbor Hater Black	6048B

FLSB 18-20

909-Twins Chrome	6520
909-Twins Black	6520B
Dual Cut Chrome	6521
Dual Cut Black	6521B

XG500/750 14-18

EL Diablo Black	6510B
-----------------	-------

XG750A 17-18

EL Diablo Black	6511B
-----------------	-------



3-INCH MUFFLERS

DYNA 91-17

FXD 95-10, FXDB 06-17, FXDL 99-09, FXDC 05-14, FXDS 95-97/2000, FXDX 00-05, FXDXT 01-03, FXDWG 95-08

	Part #
3-Inch Slashcut Chrome	6005
RPT Chrome	6055
RPT Black	6055B
Neighbor Hater Chrome	6045
Neighbor Hater Black	6045B

FXDF 08-17, FXDWG 10-17, FXDLS 16-17

3-Inch Slashcut Chrome	6006
RPT Chrome	6056
RPT Black	6056B
Neighbor Hater Chrome	6049
Neighbor Hater Black	6049B

FLD 12-16

Scalloped Tip*	6209
----------------	------

*Single Muffler

EL DIABLO SLIP-ONS FOR THE FAT BOB

The Milwaukee Eight powered Fat Bob is in a class by itself. We replaced the stock mufflers with our El Diablo slip-ons. These were made to look like they came with the bike. Our machined aluminum tips each have a lasered Cobra logo, and the mufflers aggressive style exemplifies the performance look and stance of the machine. Improved power and an incredible sound round out the package. Available in black with black tips.

6046B Softail (FXFB/S) 18-20



BAD HOMBRE DUALS

The Cobra Bad Hombre Dual exhaust system gives that classic dual exit look, while increasing performance.

The 1.75-inch exhaust tubing provides improved exhaust flow, and the 2.5-inch heat shields give the classic straight pipe look Softail riders prefer. The 24-inch muffler section ends roughly flush with the rear fender. The Fishtail style tip sticks out 6-inches further than the standard billet tip for a more custom look. Removable louvered baffles increase back-pressure and torque, as well as soften this exhaust system's bark. Offered with either 2.5-inch billet tips or a classic Fishtail style tip.

Includes oxygen sensor bungs.

BAD HOMBRE DUALS

6984 Softail 97-06
6985 Softail 07-11
6986 Softail 12-17

BAD HOMBRE DUALS WITH FISHTAILS

6987 Softail 97-06
6988 Softail 07-11
6989 Softail 12-17



DISCLAIMER: NOT LEGAL FOR SALE OR USE IN CALIFORNIA ON ANY POLLUTION CONTROLLED MOTOR VEHICLE.
THE SALE, USE, OR INSTALLATION OF THIS PRODUCT MAY ALSO BE ILLEGAL NATIONWIDE UNDER THE FEDERAL CLEAN AIR ACT (42 U.S.C. § 7522(A)(3)).

DISCLAIMER: NOT LEGAL FOR SALE OR USE IN CALIFORNIA ON ANY POLLUTION CONTROLLED MOTOR VEHICLE.
THE SALE, USE, OR INSTALLATION OF THIS PRODUCT MAY ALSO BE ILLEGAL NATIONWIDE UNDER THE FEDERAL CLEAN AIR ACT (42 U.S.C. § 7522(A)(3)).

AIR INTAKES

CONE AIR INTAKE

When it's time to put your snout to the spout where the gospel comes out, you'd best use our snorkel-like cone air intake. Its large intake tube orients the K&N filter forward, better to gulp the oncoming breeze. This thing sucks more air than an out-of-shape saxophone player. Whales use it to slurp more krill by the ton.

It is available in chrome or black and even includes our lasered and folded shield which hides the nasty unsightly bits of the throttle body tubes and connectors. Relatively simple bolt-on installation.



CONE AIR INTAKE

606-0100-06	Bagger 08-16 (Chr/Chr)
606-0100-06B	Bagger 08-16 (Blk/Blk)
606-0100-06	Softail 16-17 (Chr/Chr)
606-0100-06B	Softail 16-17 (Blk/Blk)
606-0101-06	Bagger 17-20 (Chr/Chr)
606-0101-06B	Bagger 17-20 (Blk/Blk)
606-0102-06	Bagger 00-06, Carb Model (Chr/Chr)
606-0102-06B	Bagger 00-06, Carb Model (Blk/Blk)
606-0102-06	Bagger 02-07, Fi Model (Chr/Chr)
606-0102-06B	Bagger 02-07, Fi Model (Blk/Blk)
606-0102-06	Softail 00-15/Dyna 00-15 (Chr/Chr)
606-0102-06B	Softail 00-15/Dyna 00-15 (Blk/Blk)
606-0102-06	Rocker 08-11 (Chr/Chr)
606-0102-06B	Rocker 08-11 (Blk/Blk)
606-0103-06	Sportsters 91-20 (Chr/Chr)
606-0103-06B	Sportsters 91-20 (Blk/Blk)
606-0104-06	Softails 18-20 (Chr/Chr)*
606-0104-06B	Softails 18-20 (Blk/Blk)*

*Will not fit 114 Motors

POWFLO AIR INTAKE

Though you might be tempted to install our new PowrFlo Air Intake just because it looks better than stock, you'll be getting a lot more than a great styling update. With our PowrFlo Intake system you'll see improved performance across the power band.

POWFLO AIR INTAKE

606-0100	Bagger 08-16 (Chrome)
606-0100B	Bagger 08-16 (Black)
606-0100	Softail 16-17 (Chrome)
606-0100B	Softail 16-17 (Black)
606-0101	Bagger 17-20 (Chrome)
606-0101B	Bagger 17-20 (Black)



606-0102	Bagger 00-06, Carb Model (Chrome)
606-0102B	Bagger 00-06, Carb Model (Black)
606-0102	Bagger 02-07, Fi Model (Chrome)
606-0102B	Bagger 02-07, Fi Model (Black)
606-0102	Softail 00-15/Dyna 00-15 (Chrome)
606-0102B	Softail 00-15/Dyna 00-15 (Black)

606-0102	Rocker 08-11 (Chrome)
606-0102B	Rocker 08-11 (Black)
606-0103	Sportsters 91-20 (Chrome)
606-0103B	Sportsters 91-20 (Black)
606-0104	Softails 18-20 (Chrome)*
606-0104B	Softails 18-20 (Black)*

We recommend using the F12000 PowrPro™ fuel tuner to optimize the bike's fuel because of the additional airflow available from the PowrFlo Air Intake system.

*Will not fit 114 Motors



CHROME ON CHROME



CHROME ON BLACK



BLACK ON CHROME



BLACK ON BLACK

RPT AIR CLEANER KITS

The Cobra aluminum RPT air intakes use three, machined posts mated to a sculpted mounting plate, capped off with a billet outer ring. Seven 12-point bolts secure the ring to the assembly. Comes complete with everything required for installation.

RPT AIR CLEANER KITS

606-0100-05	Bagger 08-16 (Chr/Chr)
606-0100-05B	Bagger 08-16 (Blk/Blk)
606-0100-05BC	Bagger 08-16 (Blk/Chr)
606-0100-05	Softail 16-17 (Chr/Chr)
606-0100-05B	Softail 16-17 (Blk/Blk)
606-0100-05BC	Softail 16-17 (Blk/Chr)
606-0101-05	Bagger 17-20 (Chr/Chr)
606-0101-05B	Bagger 17-20 (Blk/Blk)
606-0101-05BC	Bagger 17-20 (Blk/Chr)
606-0101-05CB	Bagger 17-20 (Chr/Blk)
606-0102-05	Bagger 00-06, Carb Model (Chr/Chr)
606-0102-05B	Bagger 00-06, Carb Model (Blk/Blk)
606-0102-05BC	Bagger 00-06, Carb Model (Blk/Chr)
606-0102-05	Bagger 02-07, Fi Model (Chr/Chr)
606-0102-05B	Bagger 02-07, Fi Model (Blk/Blk)
606-0102-05BC	Bagger 02-07, Fi Model (Blk/Chr)
606-0102-05	Rocker 08-11/Softail 00-15/Dyna 00-17 (Chr/Chr)
606-0102-05B	Rocker 08-11/Softail 00-15/Dyna 00-17 (Blk/Blk)
606-0102-05BC	Rocker 08-11/Softail 00-15/Dyna 00-17 (Blk/Chr)
606-0103-05	Sportsters 91-20 (Chr/Chr)
606-0103-05B	Sportsters 91-20 (Blk/Blk)
606-0103-05BC	Sportsters 91-20 (Blk/Chr)
606-0103-05CB	Sportsters 91-20 (Chr/Blk)
606-0104-05	Softails 18-20 (Chr/Chr)*
606-0104-05B	Softails 18-20 (Blk/Blk)*
606-0104-05BC	Softails 18-20 (Blk/Chr)*
606-0104-05CB	Softails 18-20 (Chr/Blk)*

*Will not fit 114 Motors



**THERE ARE TWO THINGS
OUR CUSTOMERS TEND
TO IGNORE. SHAVING
AND NOISE ORDINANCES.**



SWEPT CHROME

SWEPT BLACK



CROSS CHROME

CROSS BLACK



PLAIN CHROME

PLAIN BLACK



SPOKE CHROME

SPOKE BLACK

AIR CLEANER KITS	\$252.99
606-0100-01	Swept Chrome Bagger 08-16/Softail 16-17
606-0100-01B	Swept Black Bagger 08-16/Softail 16-17
606-0100-02	Cross Chrome Bagger 08-16/Softail 16-17
606-0100-02B	Cross Black Bagger 08-16/Softail 16-17
606-0100-04	Spoke Chrome Bagger 08-16/Softail 16-17
606-0101-01	Swept Chrome Bagger 17-20
606-0101-01B	Swept Black Bagger 17-20
606-0101-02	Cross Chrome Bagger 17-20
606-0101-02B	Cross Black Bagger 17-20
606-0101-03	Plain Chrome Bagger 17-20
606-0101-03B	Plain Black Bagger 17-20
606-0101-04	Spoke Chrome Bagger 17-20
606-0101-04B	Spoke Black Bagger 17-20
606-0102-01	Swept Chrome Bagger 00-06, Carb
606-0102-01B	Swept Black Bagger 00-06, Carb
606-0102-02	Cross Chrome Bagger 00-06, Carb
606-0102-02B	Cross Black Bagger 00-06, Carb
606-0102-03	Plain Chrome Bagger 00-06, Carb
606-0102-03B	Plain Black Bagger 00-06, Carb
606-0102-04	Spoke Chrome Bagger 00-06, Carb
606-0102-04B	Spoke Black Bagger 00-06, Carb
606-0102-01	Swept Chrome Bagger 02-07, Fi
606-0102-01B	Swept Black Bagger 02-07, Fi
606-0102-02	Cross Chrome Bagger 02-07, Fi
606-0102-02B	Cross Black Bagger 02-07, Fi
606-0102-03	Plain Chrome Bagger 02-07, Fi
606-0102-03B	Plain Black Bagger 02-07, Fi
606-0102-04	Spoke Chrome Bagger 02-07, Fi
606-0102-04B	Spoke Black Bagger 02-07, Fi
606-0102-01	Swept Chrome Softail 00-15/Dyna 00-17
606-0102-01B	Swept Black Softail 00-15/Dyna 00-17
606-0102-02	Cross Chrome Softail 00-15/Dyna 00-17
606-0102-02B	Cross Black Softail 00-15/Dyna 00-17
606-0102-03	Plain Chrome Softail 00-15/Dyna 00-17
606-0102-03B	Plain Black Softail 00-15/Dyna 00-17
606-0102-04	Spoke Chrome Softail 00-15/Dyna 00-17
606-0102-04B	Spoke Black Softail 00-15/Dyna 00-17
606-0103-01	Swept Chrome Sportster 91-20
606-0103-01B	Swept Black Sportster 91-20
606-0103-02	Cross Chrome Sportster 91-20
606-0103-02B	Cross Black Sportster 91-20
606-0103-03	Plain Chrome Sportster 91-20
606-0103-03B	Plain Black Sportster 91-20
606-0103-04	Spoke Chrome Sportster 91-20
606-0103-04B	Spoke Black Sportster 91-20
606-0104-01*	Swept Chrome Softails 18-20
606-0104-01B*	Swept Black Softails 18-20
606-0104-02*	Cross Chrome Softails 18-20
606-0104-02B*	Cross Black Softails 18-20
606-0104-03*	Plain Chrome Softails 18-20
606-0104-03B*	Plain Black Softails 18-20
606-0104-04*	Spoke Chrome Softails 18-20
606-0104-04B*	Spoke Black Softails 18-20

*Will not fit 114 Motors

AIR CLEANER KITS

Take the internal elements from the Powr-Flo Air Intake and replace the outside cover with trimmed down, edge-cut frames and you have Cobra's Air Cleaner kits. The frames are laser-cut steel, polished and chromed or powder-coated black. The Cobra C-over-V logo is laser cut into the top rear leg of the frame.

Four styles:
Swept, Cross, Plain and Spoke.



DISCLAIMER: NOT LEGAL FOR SALE OR USE IN CALIFORNIA ON ANY POLLUTION CONTROLLED MOTOR VEHICLE. THE SALE, USE, OR INSTALLATION OF THIS PRODUCT MAY ALSO BE ILLEGAL NATIONWIDE UNDER THE FEDERAL CLEAN AIR ACT (42 U.S.C. § 7522(A)(3)).

WHO SAYS YOU CAN'T TAKE IT WITH YOU?

Sometimes you just have to load up and light out for the frontier. It worked for Huckleberry Finn, and now with our expanded line of detachable products, it can work for you too. From backrests—tall and short—to racks—big and small—you're sure to find the right combination so that you can take all the essentials for an epic motorcycle trip whether you're heading to Sturgis or just to the Home Depot® for a couple of necessities. Fitments include Baggers, Sportsters, Softails and Dynas—old and new.



DETACHABLE BACKREST SHORT

DETACHABLE BACKREST FOR BAGGER

The Cobra detachable backrest for Baggers uses a proprietary mounting system that works best with our docking kit that bolts to the stock bike. This makes our backrest easy to install and easy to remove.

602-2000	Detachable Backrest Bagger 09-20
602-2000B	Detachable Backrest Bagger 09-20 (Black)
602-2200	Detachable Backrest Short Bagger 09-20
602-2200B	Detachable Backrest Short Bagger 09-20 (Black)
602-2100	Backrest Mounting Kit Bagger 09-13
602-2100B	Backrest Mounting Kit Bagger 09-13 (Black)
602-2101	Backrest Mounting Kit Bagger 14-20
602-2101B	Backrest Mounting Kit Bagger 14-20 (Black)



DETACHABLE LUGGAGE RACKS

These detachable racks work seamlessly with our detachable backrest. Using the same proprietary release mechanism as the backrest, they can be installed or removed in a matter of seconds. These Bagger versions can be used with or without our detachable backrest but requires the Cobra docking hardware kit.

They come in a standard version available in chrome or black, and in our new 18-inch wide by 13.5-inch deep Big Ass Rack, also available in chrome or black.

DETACHABLE LUGGAGE RACK

602-2500 Bagger 09-20
602-2500B Bagger 09-20 (Black)

DETACHABLE RACKS (ORIGINAL BIG ASS)

602-2600 Bagger 09-20
602-2600B Bagger 09-20 (Black)

DETACHABLE RACKS (BIG ASS FLAT)

602-2800 Bagger 09-20
602-2800B Bagger 09-20 (Black)



BIG ASS FLAT



DETACHABLE LUGGAGE RACK



ORIGINAL BIG ASS



ORIGINAL BIG ASS (BLACK)



BIG ASS FLAT (BLACK)



TWO UP TOUR PACK MOUNT



TWO UP TOUR PACK MOUNT (BLACK)

DETACHABLE TOUR PACK MOUNTS

For riders looking to mount a tour pack to their Street Glides or Road Glides or other models, we now offer a couple of options. For the 1997-2008 Baggers we have a simple mount in chrome. It requires you use both the front and rear docking hardware (two separate items that are not included and must be purchased separately). This mount is available in chrome only.

For the 2009-2013 Baggers we have a standard chrome tour pack mount and a version for riders with a solo seat. Both require the Cobra four-point docking hardware (602-2100/2100B). And for the 2014-2020 models we have a similar tour pack mount and solo mount that requires the four-point docking hardware (602-2101/2101B). For these later model years, the mounts are available in chrome or black.

602-2102	Front Docking Kit Bagger 97-08
602-2103	Rear Docking Kit Bagger 97-08
602-2700	Two Up Tour Pack Mount Bagger 97-08
602-2701	Two Up Tour Pack Mount Bagger 09-13
602-2702	Two Up Tour Pack Mount Bagger 14-20
602-2702B	Two Up Tour Pack Mount Bagger 14-20 (Black)
602-2703	Solo Tour Pack Mount Bagger 09-13
602-2704	Solo Tour Pack Mount Bagger 14-20
602-2704B	Solo Tour Pack Mount Bagger 14-20 (Black)
602-2100	Mounting Kit Bagger 09-13
602-2100B	Mounting Kit Bagger 09-13 (Black)
602-2101	Mounting Kit Bagger 14-20
602-2101B	Mounting Kit Bagger 14-20 (Black)

TWO UP TOUR PACK MOUNT BAGGER 97-08



DETACHABLE BACKRESTS

DETACHABLE BACKREST FOR DYNAS, SOFTTAILS AND SPORTSTERS

A detachable backrest offers the best of both worlds for a rider. It offers the convenience of a practical and comfortable back support, but one that is easily removed for around town riding. What really sets this detachable backrest system apart from the rest, is that there is no need to relocate the stock turn signals. Each is bike specific and arrives with everything needed to install on the bike, including mounting hardware. Round bars have a Cobra branded insert, while the square bars do not.

NOTE: These backrests include all mounting hardware. They do not work with nor require the Harley-Davidson mounting kits.

MINI-BLACK



MINI-CHROME

DETACHABLE BACKREST (Mini) - Chrome/Black

602-2021/602-2021B	FLSTF 00-06, FXST/S/B 00-05, FLSTC 00-17, FLSTN 07-17, FLSTS 00-03
602-2022/602-2022B	FLSTF 07-17, FXST/S/B 06-09
602-2024/602-2024B	FXD 06-10, FXDB 06-17, FXDC 06-14, FXDL 06-09, FXDL 14-17
602-2025/602-2025B	Sportsters 04-20 (Not Roadster 16-17)
602-2026/602-2026B	FLDE/FLSL/FXBB 18-20
602-2027/602-2027B	FLFB/S, FXBR/S 18-20
602-2028B	FXFB/S 18-20
602-2029/602-2029B	FXLR/S 18-20
602-2030/602-2030B	FLHC/S 18-20
602-2031/602-2031B	FLSB 18-20

DETACHABLE BACKREST (Short) - Chrome/Black

602-2041/602-2041B	FLSTF 00-06, FXST/S/B 00-05, FLSTC 00-17, FLSTN 07-17, FLSTS 00-03
602-2042/602-2042B	FLSTF 07-17, FXST/S/B 06-09
602-2044/602-2044B	FXD 06-10, FXDB 06-17, FXDC 06-14, FXDL 06-09, FXDL 14-17
602-2045/602-2045B	Sportsters 04-20 (Not Roadster 16-17)
602-2046/602-2046B	FLDE/FLSL/FXBB 18-20
602-2049/602-2049B	FXLR/S 18-20
602-2050/602-2050B	FLHC/S 18-20
602-2051/602-2051B	FLSB 18-20

SHORT-BLACK



SHORT-CHROME

ROUND-BLACK

BOLT-ON RACKS FOR THE COBRA DETACHABLE BACKREST

These racks are for our detachable backrests for Dyna, Softail and Sportster models. They bolt directly to the backrest and are available in a chrome or black finish. They are a stylish combination of tube and laser cut steel.

BOLT-ON RACKS FOR DETACHABLE BACKREST

602-3500	Tube Luggage Rack (Chrome) Fits 602-2001/602-2021/602-2041/602-2004/602-2024/602-2044/602-2005/602-2025/602-2045/602-2006/602-2026/602-2046/602-2010/602-2030/602-2050
602-3500B	Tube Luggage Rack (Black) Fits 602-2001B/602-2021B/602-2041B/602-2004B/602-2024B/602-2044B/602-2005B/602-2025B/602-2045B/602-2006B/602-2026B/602-2046B/602-2010B/602-2030B/602-2050B
602-3501	Tube Luggage Rack (Chrome) Fits 602-2002/602-2022/602-2042/602-2009/602-2029/602-2049/602-2011/602-2031/602-2051
602-3501B	Tube Luggage Rack (Black) Fits 602-2002B/602-2022B/602-2042B/602-2009B/602-2029B/602-2049B/602-2011B/602-2031B/602-2051B/602-2028B
602-3502	Tube Luggage Rack (Chrome) Fits 602-2007/602-2027
602-3502B	Tube Luggage Rack (Black) Fits 602-2007B/602-2027B

ROUND-CHROME



BOLT-ON RACK FOR DETACHABLE BACKREST

DETACHABLE BACKRESTS

DETACHABLE BACKREST (Round) - Chrome/Black

602-2001/602-2001B	FLSTF 00-06, FXST/S/B 00-05, FLSTC 00-17, FLSTN 07-17, FLSTS 00-03
602-2002/602-2002B	FLSTF 07-17, FXST/S/B 06-09
602-2004/602-2004B	FXD 06-10, FXDB 06-17, FXDC 06-14, FXDL 06-09, FXDL 14-17
602-2005/602-2005B	Sportsters 04-20 (Not Roadster 16-17)
602-2006/602-2006B	FLDE/FLSL/FXBB 18-20
602-2007/602-2007B	FLFB/S, FXBR/S 18-20
602-2009/602-2009B	FXLR/S 18-20
602-2010/602-2010B	FLHC/S 18-20
602-2011/602-2011B	FLSB 18-20

DETACHABLE LUGGAGE RACKS

DETACHABLE SOLO LUGGAGE RACKS

These detachable racks use our proprietary pull release mechanism, so they can be installed or removed in a matter of seconds. They arrive with all the necessary hardware needed for installation and come in a standard version available in chrome or black, and in our new 18-inch wide by 13.5-inch deep Big Ass Rack, also available in chrome or black.

DETACHABLE RACKS (Standard) - Chrome/Black

602-2510/602-2510B FLSL/FXBB 18-20
 602-2511/602-2511B FLDE 18-20
 602-2514/602-2514B FLHC 18-20

DETACHABLE RACKS (Big Ass) - Chrome/Black

602-2610/602-2610B FLSL/FXBB 18-20
 602-2614/602-2614B FLHC 18-20

NOTE: These racks include all mounting hardware. They do not work with nor require the Harley-Davidson mounting kits.



STANDARD



BIG ASS



DETACHABLE LUGGAGE RACKS

For riders who prefer a two-up seat, we've designed the Cobra Big Ass Wrap Around racks. Each is model specific, and we have two basic versions. The first is for riders using a stock OEM style seat. It has a larger opening to fit around the stock seat and overall it is nearly 19-inches wide. It's approximately 13-inches front to back. The second version is for riders using some of the narrower aftermarket seats like the Saddleman Step Up or the Lucky Daves step up seat. This rack for aftermarket seats is about 2-inches narrower side to side than the one for OEM seats, but the same 13-inches front to back.

The top of the rack is about level with the top of the seat and each rack has a kick up in the rear. The middle of the rear section uses a laser-cut, formed steel plate to hold your cargo in place. There are plenty of places to attach bungee cords or mounting straps so you no longer have to scratch your bike's fender as you secure your cargo.

DETACHABLE (BIG ASS) WRAP AROUND LUGGAGE RACKS - Chrome/Black

602-2611/602-2611B FXBB/FLSL 18-20
 602-2612/602-2612B FLFB/FLBR 18-20
 602-2613/602-2613B FXLR/S 18-20
 602-2615/602-2615B FLSB 18-20
 XXX-XXXX/602-2616B FXFB 18-20
 602-2620/602-2620B Sportster 04-20
 602-2630/602-2630B Dyna w/
 OEM Seat 06-17
 602-2631/602-2631B Dyna w/
 Saddlemen Seat
 06-17

NOTE: These racks include all mounting hardware. They do not work with nor require the Harley-Davidson mounting kits.

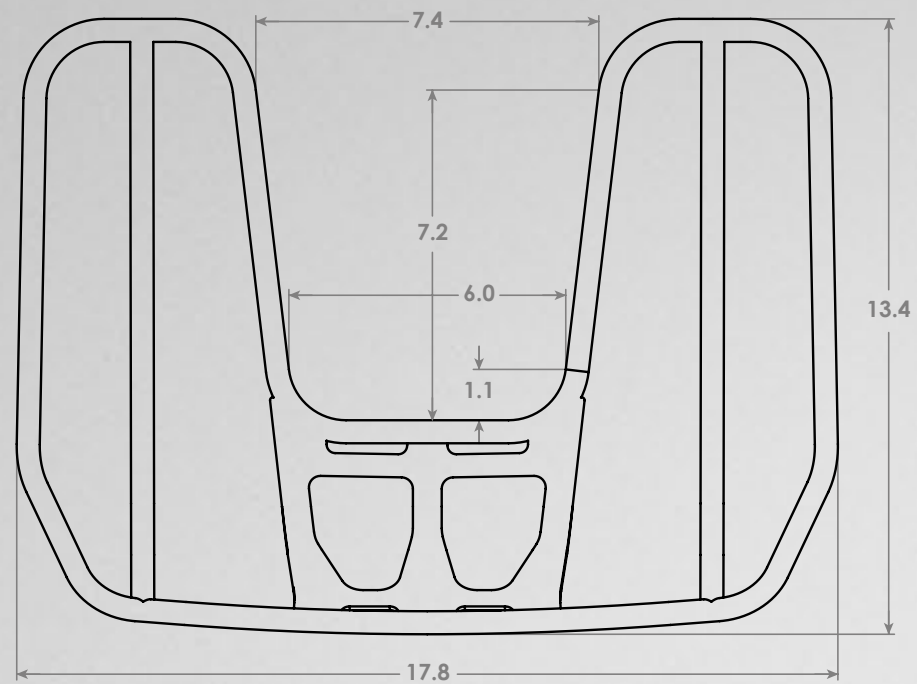

RACK #1

- | | |
|-----------|--|
| 602-2611 | FXBB Street Bob 18-20, FLSL Softail Slim 18-20 |
| 602-2611B | FXBB Street Bob 18-20, FLSL Softail Slim 18-20 (Black) |

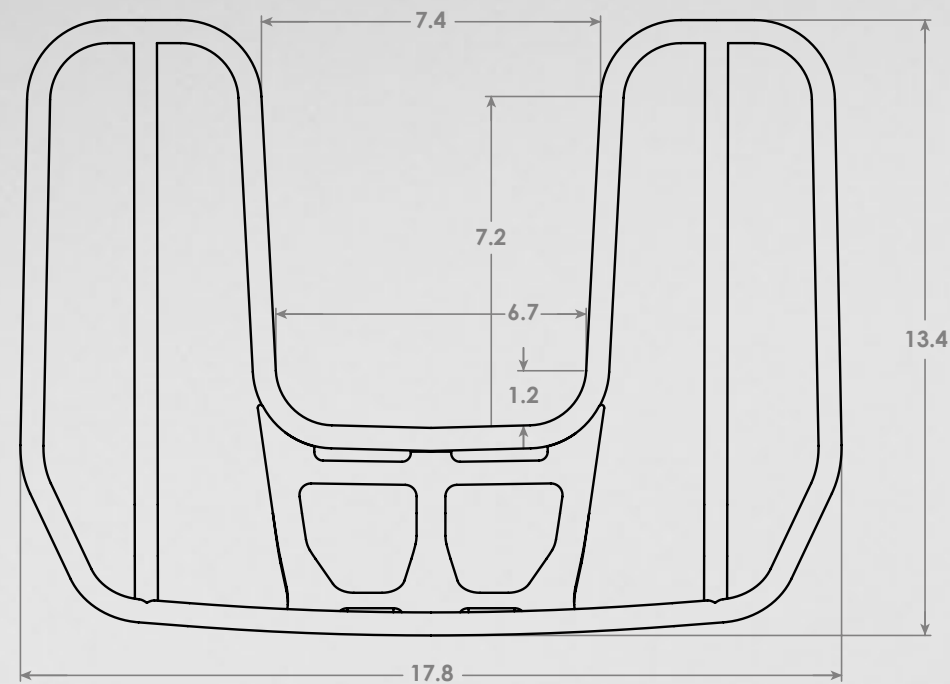

RACK #2

- | | |
|------------|--|
| 602-2616B | FXFB Fat Bob 18-20 (Black) |
| 602-2620 | Sportster 04-29 |
| 602-2620B | Sportster 04-20 (Black) |
| 602-2631* | Dyna with Saddlemen seat 06-17 |
| 602-2631B* | Dyna with Saddlemen seat 06-17 (Black) |

*Will not fit FXDWG and FXDF models

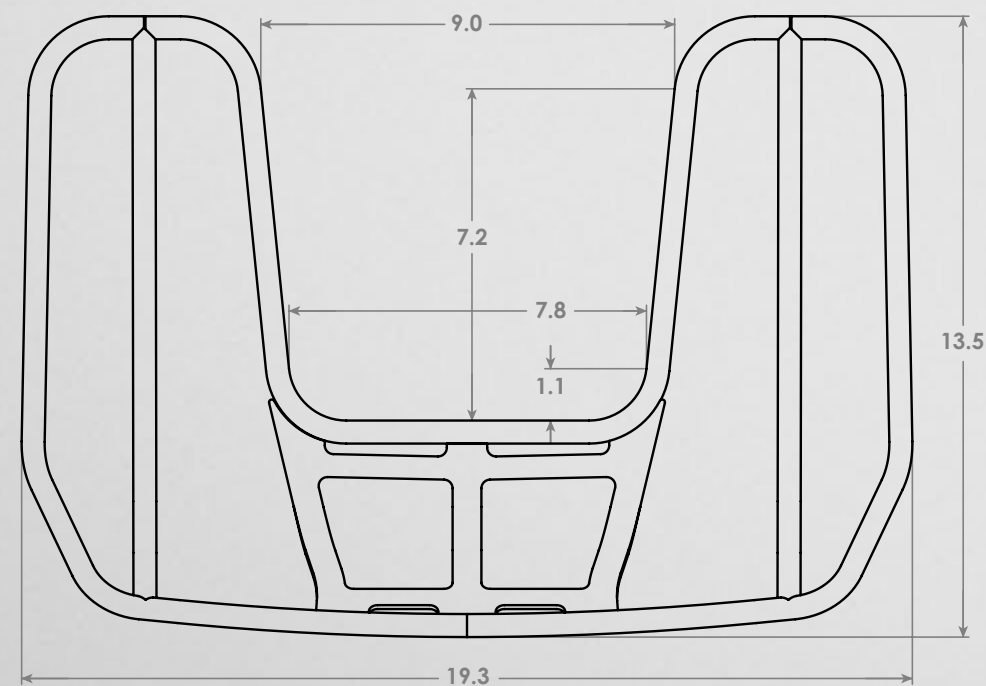

RACK #3

- | | |
|------------|---|
| 602-2612 | FLFB Fat Boy, FXBR Breakout 18-20 |
| 602-2612B | FLFB Fat Boy, FXBR Breakout 18-20 (Black) |
| 602-2613 | FXLR Lowrider 18-20 |
| 602-2613B | FXLR Lowrider 18-20 (Black) |
| 602-2615 | FLSB Sportglide 18-20 |
| 602-2615B | FLSB Sportglide 18-20 (Black) |
| 602-2630* | Dyna w/ OEM seat 06-17 |
| 602-2630B* | Dyna w/ OEM seat 06-17 (Black) |

*Will not fit FXDWG and FXDF models



SISSY BAR HEIGHTS



STANDARD



SHORT



MINI

SISSY BARS

Whether you're going for the '60s chopper look, want to strap something down in back, or simply want your passenger to talk to you after a long ride, you'll find our sissy bars are a great addition to any bike. Available in either square or round, they're built from high-strength steel and then polished and chromed or powder coated black. And each one is custom-built to fit your specific bike, so there are no hassles with cutting, drilling or spacing.

Each sissy bar comes with everything you need: The bar, pad and mounting brackets are all covered with one part number.

MINI SISSY BARS (Chrome/Black)

- | | |
|--------------------|---|
| 602-1100 | Softail (FLSTF 00-06, FXST/S/B 00-05) |
| 602-1101/602-1101B | Softail (FLSTF 07-17, FXST/S/B 06-09) |
| 602-1102/602-1102B | Dyna (FXD/B/C/L 06-17) |
| 602-1103/602-1103B | Sportster (XL 04-20) |
| 602-1104 | Softail (FLSTC 00-17, FLSTN 07-17, FLSTS 00-03) |

SHORT SISSY BARS (Chrome/Black)

- | | |
|--------------------|---|
| 602-1200 | Softail (FLSTF 00-06, FXST/S/B 00-05) |
| 602-1201/602-1201B | Softail (FLSTF 07-17, FXST/S/B 06-09) |
| 602-1202/602-1202B | Dyna (FXD/B/C/L 06-17) |
| 602-1203/602-1203B | Sportster (XL 04-20) |
| 602-1204 | Softail (FLSTC 00-17, FLSTN 07-17, FLSTS 00-03) |

STANDARD SISSY BARS (Chrome/Black)

- | | |
|--------------------|---|
| 602-1150 | Softail (FLSTF 00-06, FXST/S/B 00-05) |
| 602-1151/602-1151B | Softail (FLSTF 07-17, FXST/S/B 06-09) |
| 602-1152/602-1152B | Dyna (FXD/B/C/L 06-17) |
| 602-1153/602-1153B | Sportster (XL 04-20) |
| 602-1154 | Softail (FLSTC 00-17, FLSTN 07-17, FLSTS 00-03) |

SHORT ROUND SISSY BARS (Chrome/Black)

- | | |
|--------------------|---|
| 602-1300 | Softail (FLSTF 00-06, FXST/S/B 00-05) |
| 602-1301/602-1301B | Softail (FLSTF 07-17, FXST/S/B 06-09) |
| 602-1302/602-1302B | Dyna (FXD/B/C/L 06-17) |
| 602-1303/602-1303B | Sportster (XL 04-20) |
| 602-1304 | Softail (FLSTC 00-17, FLSTN 07-17, FLSTS 00-03) |

STANDARD ROUND SISSY BARS (Chrome/Black)

- | | |
|--------------------|---|
| 602-1251/602-1251B | Softail (FLSTF 07-17, FXST/S/B 06-09) |
| 602-1252/602-1252B | Dyna (FXD/B/C/L 06-17) |
| 602-1253/602-1253B | Sportster (XL 04-20) |
| 602-1254 | Softail (FLSTC 00-17, FLSTN 07-17, FLSTS 00-03) |

SISSY BAR LUGGAGE RACKS

When you're out on the road, you're either the low maintenance type or you're like everyone else and like to bring a few things along—and that's when our sissy bar luggage racks are a real blessing. They bolt directly to any of our sissy bars and provide a great place for carrying soft luggage or an overnight bag. And as easily as they install and carry your stuff, they're also just as easy to take off for a cleaner look when you're in town.

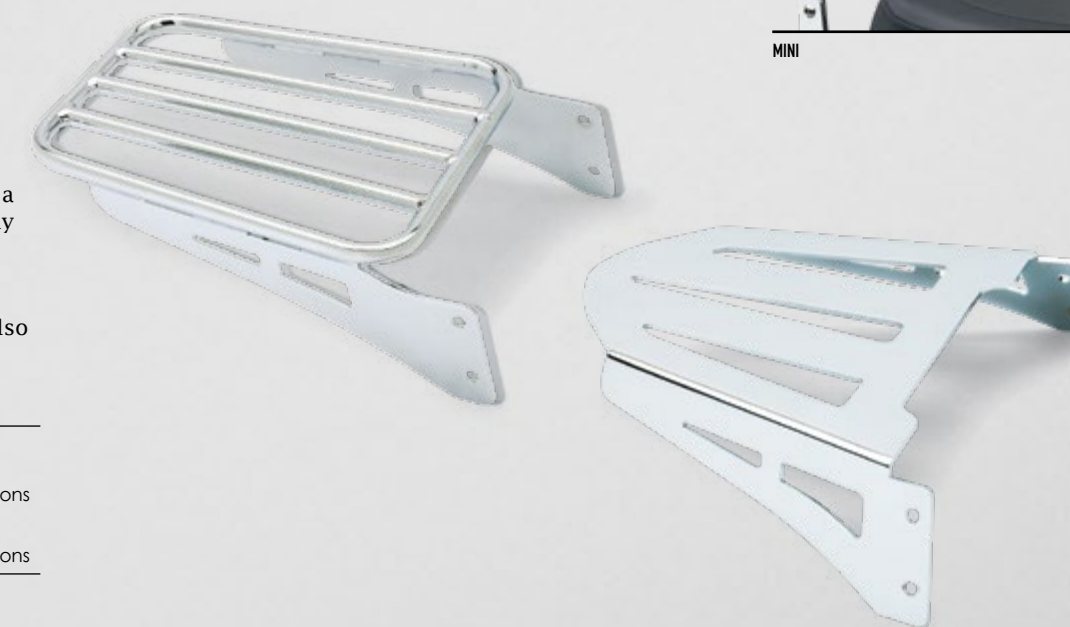

SISSY BAR LUGGAGE RACKS (Chrome/Black)

- | | |
|------------------|---|
| 02-3500/02-3500B | Luggage Rack (Tube)
Will fit all Harley applications |
| 02-3600/02-3600B | Luggage Rack (Formed)
Will fit all Harley applications |

FREEWAY BARS

There isn't a much better feeling than stretching out and just rolling down the open road. After all, it's why you're on a cruiser in the first place. So why not do it in real comfort on a set of our freeway bars? Fabricated from super-stout 1.25-inch steel tube with heavy-duty welded flanges, you won't find a more solid, yet comfortable platform to kick back on. And if nothing is ever big enough or bad enough for you, we also offer them in 1.5-inch fatty as well for an even beefier look. Plus, they work with our lightbars, floorboards and accessories.

Our newest freeway bar presents a more aggressive V-shape, narrower at the bottom than at the top with tighter bends. Available first for the new Softails.

FREEWAY BARS

601-2100	Softail (All FL Models, except FLSTC) 00-17
601-2105	Softail (FLSTC) 00-17
601-2101	Dyna (FXD/B/C) 91-17
601-2106	Sportster (XL) 04-20

FREEWAY BARS - BLACK

601-2100B	Softail (All FL Models, except FLSTC) 00-17
601-2101B	Dyna (FXD/B/C) 91-17
601-2106B	Sportster (XL) 04-20

FATTY FREEWAY BARS

601-2200	Softail (All FL Models, except FLSTC) 00-17
601-2205	Softail (FLSTC) 00-17
601-2201	Dyna (FXD/B/C) 91-17
601-2202	Bagger (FLHT/C, FLHR/C, FLHX) 97-08
601-2203	Bagger (FLHT, FLHR, FLHX) 09-20

V-BEND FREEWAY BARS

601-2107	Softail (FXBB, FXLR/S) 18-20
601-2107B	Softail (FXBB, FXLR/S) 18-20
601-2108	Softail 18-20 (Not FXDR114)
601-2108B	Softail 18-20 (Not FXDR114)
601-2109	Sportster (XL) 04-20
601-2109B	Sportster (XL) 04-20
601-2110	Dyna (FXD/B/C) 91-17
601-2110B	Dyna (FXD/B/C) 91-17

NOTE: Will not fit Dyna models with forward controls. Will not fit Sportster models with chin spoilers or forward controls. Will not fit Bagger models equipped with fairing lowers.



SISSY BAR INSERTS

Here's the perfect way to personalize your Stock Harley® OEM and Cobra Sissy Bars. We now offer designs from the mild Chevron look to the wild Flaming Skull. You can even go Tribal if you feel like it. Each is made from high grade steel, with a precision laser-cut design. Each is polished smooth then chrome plated to match the finish on the Sissy Bar.

SISSY BAR INSERTS (FITS STOCK HARLEY® OEM SISSY BARS)



CROSS INSERT

TRIBAL INSERT

SWEPT INSERT

FLAG INSERT

602-5053	Bagger OEM Detachable Sissy Bar Cross
602-5054	Bagger OEM Detachable Sissy Bar Tribal
602-5055	Bagger OEM Detachable Sissy Bar Swept
602-5056	Bagger OEM Detachable Sissy Bar Flag
602-5057	Bagger OEM Detachable Sissy Bar Finger



PLAIN INSERT



CHEVRON INSERT

SISSY BAR INSERTS (FITS COBRA SISSY BARS)



CROSS INSERT



TRIBAL INSERT



SKULL INSERT



SWEPT INSERT



FLAG INSERT

02-5022	Replacement Standard Sissy Bar Pad (Freedom)
02-5026	Replacement Short/Mini Sissy Bar Pad (Freedom)
02-5035	Billet Insert Cobra (Fits Cobra Standard Bar)
02-5050	Backrest Insert Steel (Fits Standard) Plain
02-5052	Backrest Insert Steel (Fits Standard) Skull
02-5053	Backrest Insert Steel (Fits Standard) Cross
02-5054	Backrest Insert Steel (Fits Standard) Tribal
02-5055	Backrest Insert Steel (Fits Standard) Swept
02-5056	Backrest Insert Steel (Fits Standard) Flag
02-5057	Backrest Insert Steel (Fits Standard) Finger
02-5060	Backrest Insert Steel (Fits Short/Mini) Plain

02-5062	Backrest Insert Steel (Fits Short/Mini) Skull
02-5063	Backrest Insert Steel (Fits Short/Mini) Cross
02-5064	Backrest Insert Steel (Fits Short/Mini) Tribal
02-5066	Backrest Insert Steel (Fits Short/Mini) Flag
02-5067	Backrest Insert Steel (Fits Short/Mini) Finger
02-5071	Backrest Insert Steel (Fits Round) Skull
02-5072	Backrest Insert Steel (Fits Round) Cross
02-5073	Backrest Insert Steel (Fits Round) Tribal
02-5074	Backrest Insert Steel (Fits Round) Swept
02-5077	Backrest Insert Steel (Fits Round) Finger



BUMPER

This bumper is a simple bolt-on upgrade for your Freewheeler trike. It uses laser cut brackets, for a precision fit and finish. The bumper's graceful bend follows the trike's lower trunk curve for an OEM look and fit. The bumper itself is chrome plated, while the lower mounting brackets are powder coated black.

602-3100 Trunk Guard Freewheeler 15-20



LUGGAGE RACK

Our sturdy Freewheeler tube luggage rack mounts directly to the trike's trunk lid. It mounts in the same way and location of the H-D version. Thus, it requires four holes to be drilled in the trunk using the designated OEM mounting locations. The chrome plated rack has an upward bend at the rear to help secure items bungeed or lashed onto it.

602-3000 Tube Luggage Rack Freewheeler 15-20

ACCESSORIES



SADDLEBAG SUPPORTS

602-6100	Softail (FLST 00-17, FXST 00-17)
602-6102	Softail (FXSB 13-17)
602-6103	Sportster (XL 04-20)



UNIVERSAL HEAT SHIELDS – 10"

99-0181P 2" X 10"

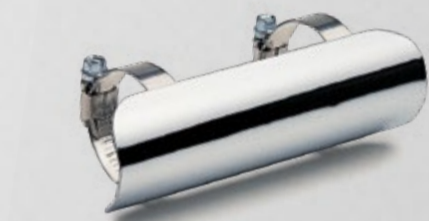

UNIVERSAL HEAT SHIELDS – 6"

99-0155P	1-3/4" x 6"
99-0165P	2" x 6"
99-0175P	2-1/4" x 6"

Fi2000*

DIGITAL FUEL PROCESSOR

HARLEY Fi2000R O2*

692-1608CL	Bagger	2007
692-1608CL-50	Bagger	2007 (ARB)
692-1612CL	Bagger	08-09
692-1612CL-50	Bagger	08-09 (ARB)
692-1615CL	Bagger	10-13
692-1615CL-50	Bagger	10-13 (ARB)
692-1629CL	Bagger	14-16
692-1631CL	Bagger	17-20
692-1609CL	Dyna	2006
692-1609CL-50	Dyna	2006 (ARB)
692-1606CL	Dyna	2007
692-1606CL-50	Dyna	07-11 (ARB)
692-1610CL	Dyna	08-11
692-1616CL	Dyna	12-17
692-1616CL-50	Dyna	12-13 (ARB)
692-1607CL	Softail	2007
692-1607CL-50	Softail	07-11 (ARB)
692-1614CL	Softail	08-11
692-1625CL	Softail CVO	10-11
692-1617CL	Softail	12-15
692-1617CL-50	Softail	12-13 (ARB)
692-1626CL	Softail CVO	12-17
692-1624CL	Softail	16-17
692-1632CL	Softail	18-20
692-1611CL	Rocker	08-11
692-1611CL-50	Rocker	08-11 (ARB)
692-1620CL	Sportsters	07-13
692-1620CL-50	Sportsters	07-13 (ARB)
692-1621CL	Sportster72	12-13
692-1622CL	Sportster	14-20
692-1613CL	V-Rod	08-11
692-1613CL-50	V-Rod	08-11 (ARB)
692-1618CL	V-Rod	12-17
692-1618CL-50	V-Rod	12-13 (ARB)

OXYGEN SENSOR ELIMINATOR

692-1100	Dyna 06-09
----------	------------

*California residents should purchase the Fi2000R ARB, which is approved for sale in California. ARB E.O. No. D-633-1. Note: ARB units for use in California are not adjustable.

Fi2000R

- Reduces engine heat.
- The Fi2000R has been shown to lower the cylinder-head temperatures considerably on some late-model Harley-Davidson motorcycles, especially bagger models. That lower cylinder-head temperature noticeably improves rider and passenger comfort.
- Tunes your H-D for optimal performance.
- With no computer downloads and an installation that's the easiest in the business, the Fi2000R can have your bike running better and cooler in under an hour.
- California-approved models available.

HARLEY Fi2000R*

692-1600	Bagger	95-05
692-1600-50	Bagger	95-05 (ARB)
692-1602	Bagger	2006
692-1602-50	Bagger	2006 (ARB)
692-1608	Bagger	2007
692-1612	Bagger	08-09
692-1605	Dyna	01-05
692-1605-50	Dyna	01-05 (ARB)
692-1606	Dyna	06-11
692-1611	Rocker	08-11
692-1605	Softail	01-05
692-1605-50	Softail	01-05 (ARB)
692-1604	Softail	2006
692-1604-50	Softail	2006 (ARB)
692-1606	Softail	07-11
692-1620	Sportsters	07-13
692-1601	V-Rod	02-07
692-1601-50	V-Rod	02-07 (ARB)
692-1613	V-Rod	08-11

Fi2000R O2

THE Fi2000R O2 WORKS WITH OXYGEN-SENSOR -EQUIPPED EXHAUST SYSTEMS

The motorcycle engines utilizing oxygen sensors and closed-loop technology have very lean air/fuel mixture settings from the factory. These settings can limit power and make the engines run hotter than earlier models. The Fi2000R O2 digital fuel processor is designed to work with all exhaust systems (stock or aftermarket) equipped with oxygen sensors. It accurately adjusts the fuel-injected engine's air/fuel ratio in order for it to run properly. Best of all, it works much like a carburetor jet kit with adjustments similar to the air-mixture screw, the needle and clip positions and the main jet.

- The Fi2000R O2 may increase horsepower and torque by optimizing stock lean air/fuel mixtures and also helps cool the engine temperature.
- Quick and simple plug-and-ride installation with OEM-style connectors.
- No confusing computer downloads to install.
- No expensive dyno testing required.
- Preconfigured from the factory for your make and model, but easy to adjust should your specific application need it.
- Units for use in California are not adjustable.
- Improves overall rideability.



Fi2000R® DIGITAL FUEL PROCESSOR

Fi2000R O2® DIGITAL FUEL PROCESSOR



This is the new and improved version of the award winning PowrPro fuel tuner, now using the latest accelerometer enabled software for precise real-time tuning. Once you install the PowrPro Black you can say good-bye to old-school EFI "mapping products" and O2 sensor hassles. The PowrPro Black reacts to the bike's acceleration to adjust for the optimum air/fuel mixture, under every kind of load and under all existing conditions. And here's the really great news, should you need to adjust your bike's air fuel ratio outside of the acceleration area, you can do that now with your smart device and our cloud based app. You can download the free app by visiting the app store of your choice and searching for PowerPro Black.

POWRPRO BLACK

DIGITAL FUEL PROCESSOR

POWRPRO BLACK

692-1600B	Bagger	02-05
692-1602B	Bagger	2006
692-1608B	Bagger	2007
692-1612B	Bagger	08-09
692-1627B	Bagger Police	08-09
692-1615B	Bagger	10-13
692-1628B	Bagger Police	10-13
692-1629B	Bagger	14-16
692-1631B	Bagger	17-20
692-1605B	Dyna	01-05
692-1609B	Dyna	2006
692-1606B	Dyna	2007
692-1610B	Dyna	08-11
692-1616B	Dyna	12-17
692-1630B	Dyna Low Rider S	16-17
692-1605B	Softail	01-05
692-1604B	Softail	2006
692-1607B	Softail	2007
692-1614B	Softail	08-11
692-1625B	Softail CVO	10-11
692-1617B	Softail	12-15
692-1626B	Softail CVO	12-17
692-1624B	Softail	16-17
692-1632B	Softail	18-20
692-1611B	Rocker	08-11
692-1620B	Sportsters	07-13
692-1621B	Sportster72	12-13
692-1622B	Sportster 883	14-20
692-1623B	Sportster 1200	14-20
692-1601B	V-Rod	02-07
692-1613B	V-Rod	08-11
692-1618B	V-Rod	12-17
692-1603B	Mag Marelli	95-01

DISCLAIMER: NOT LEGAL FOR SALE OR USE IN CALIFORNIA ON ANY POLLUTION CONTROLLED MOTOR VEHICLE.

THE SALE, USE, OR INSTALLATION OF THIS PRODUCT MAY ALSO BE ILLEGAL NATIONWIDE UNDER THE FEDERAL CLEAN AIR ACT (42 U.S.C. § 7522(A)(3)).

DISCLAIMER: NOT LEGAL FOR SALE OR USE IN CALIFORNIA ON ANY POLLUTION CONTROLLED MOTOR VEHICLE.

THE SALE, USE, OR INSTALLATION OF THIS PRODUCT MAY ALSO BE ILLEGAL NATIONWIDE UNDER THE FEDERAL CLEAN AIR ACT (42 U.S.C. § 7522(A)(3)).

SIT BACK.
RELAX.
ENJOY THE RIDE.
REPEAT.

