

BAKER 6-INTO-4 INSTALLATION INSTRUCTIONS

6 INTO 4 BY BAKER DRIVETRAIN



H6402P Shown with optional bearing support (pn 6-4SSAP-A)



BAKER 6-INTO-4 INSTALLATION INSTRUCTIONS

FEATURES

- 6061-T6 billet case and trap door provides more strength over the stock cast case
- BAKER™ Klassic Kickers gears installed with kicker transmissions
- Lower than stock first gear
- Improved neutral location with redundant neutral system and/or N1 shift drum
- RPM reduction at highway speeds in cruising gears
- Short, accurate shifts
- Kicker transmissions include the stainless steel BAKER™ Kick Arm assembly
- Optional 3.24 1st gear available
- Available with 23T or 24T chain sprocket or 33T belt pulley

APPLICATION

- 1976-Early 1984 FL/FX Shovelhead (FX with mid controls will require more modification)
- 1936-1964 Models
- Late 1984-1986
- 1965-1969 with modifications
- Custom applications

NOTES

Moderate skill level is required for installation. As with most things in life there are no substitutes for skill and experience. It is highly recommended by BAKER™ that when performing this task or any task related to the drivetrain components on your motorcycle, that you refer to the Factory Service Manual for you specific model of bike.

BAKER 6-INTO-4 INSTALLATION INSTRUCTIONS

TABLE OF CONTENTS:

- 2) Overview Application
- 3) Table Of Contents
- 4) Exploded View Transmission Case
- 5) Exploded View Gearset
- 6) Exploded View Transmission Case
- 7) Exploded View Hydraulic Side Cover
- 8) Exploded View & Parts List, Hydraulic Type, Function Form
- 9) Exploded View & Parts List, Billet Mechanical Type
- 10) Exploded View & Parts List, Cable Type
- 11) Specifications and Torque Values
- 12) Getting Started
- 13) Required Tools and Parts
- 14) Installation
- 15) Warranty
- 16) Disclaimer

BAKER 6-INTO-4 INSTALLATION INSTRUCTIONS

EXPLODED VIEW: SHIFT SYSTEM AND FINAL DRIVE

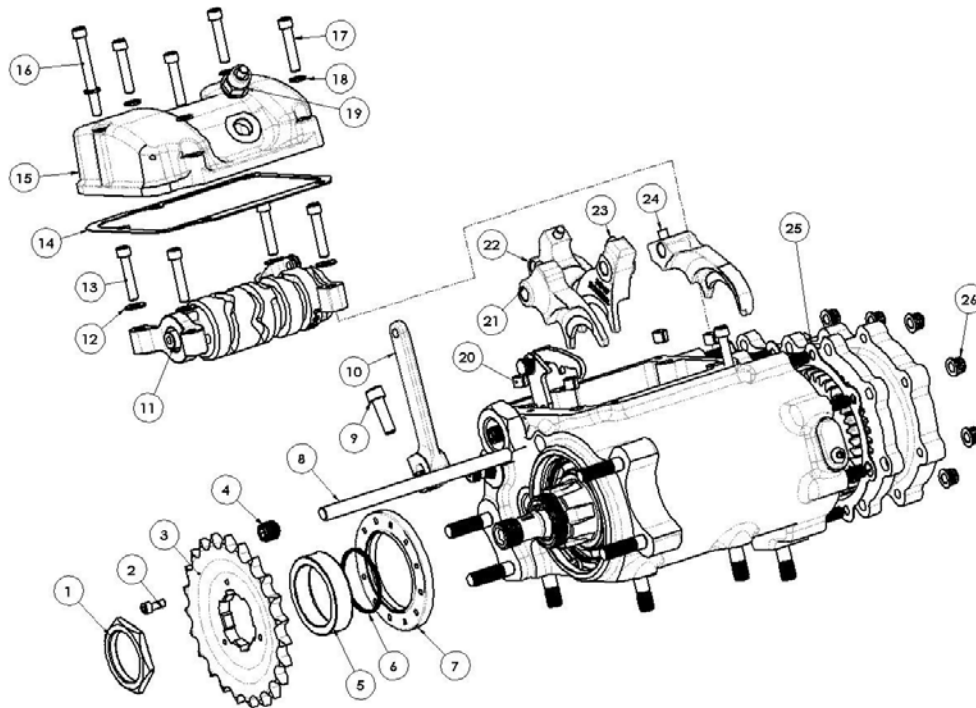

ITEM	QTY	PN	DESCRIPTION
1	1	35211-91-6N4	Nut, sprocket
2	1	10C25KLH	10-24x1/4 Low Head Screw
3	1	23T-64, (24T-64 or 32181S)	23T sprocket or optional 24T or 33T belt pulley
4	1	25702	1/2-20 x 1/2" Plug
5	1	33344-6-4	Spacer, sprocket
6	1	11165A	Quad seal
7	1	12067B	Seal, main drive gear
8	1	122-6-4	Fork rod
9	1	31C100KCSS/P	5/16-24 x 1" SHCS SS
10	1	33715-85SA	Shift lever
11	1	124A-OD6-A	6INTO4 shift system
12	4	33001	Washer, pillow block
13	4	23207	1/4-20 x 1 1/4" SHCS
14	1	34904-86E	Gasket, Top cover
15	1	34468-56	Top cover
16	1	25C250KCSS/P	1/4-20 x 2 1/2 SHCS SS
17	1	25C150KCSS/P	1/4-20 x 1 1/2 SHCS SS
18	3	25C125KCSS/P	1/4-20 x 1 1/4 SHCS SS
19	5	6099SS	Washer, top cover
20	1	33900-59	Neutral switch, single pole
21	6	609B	Alignment dowel
22	1	101-56	Fork, 2M
23	1	102-6E	Fork, 4C
24	1	102-5F	Fork, 3C
25	1	101-6E	Fork, 1M
26	1	6N4-GAS	Gasket, trap door
27	9	31FNT8Z	5/16-24, 12 point nut

BAKER 6-INTO-4 INSTALLATION INSTRUCTIONS

EXPLODED VIEW: GEARSET

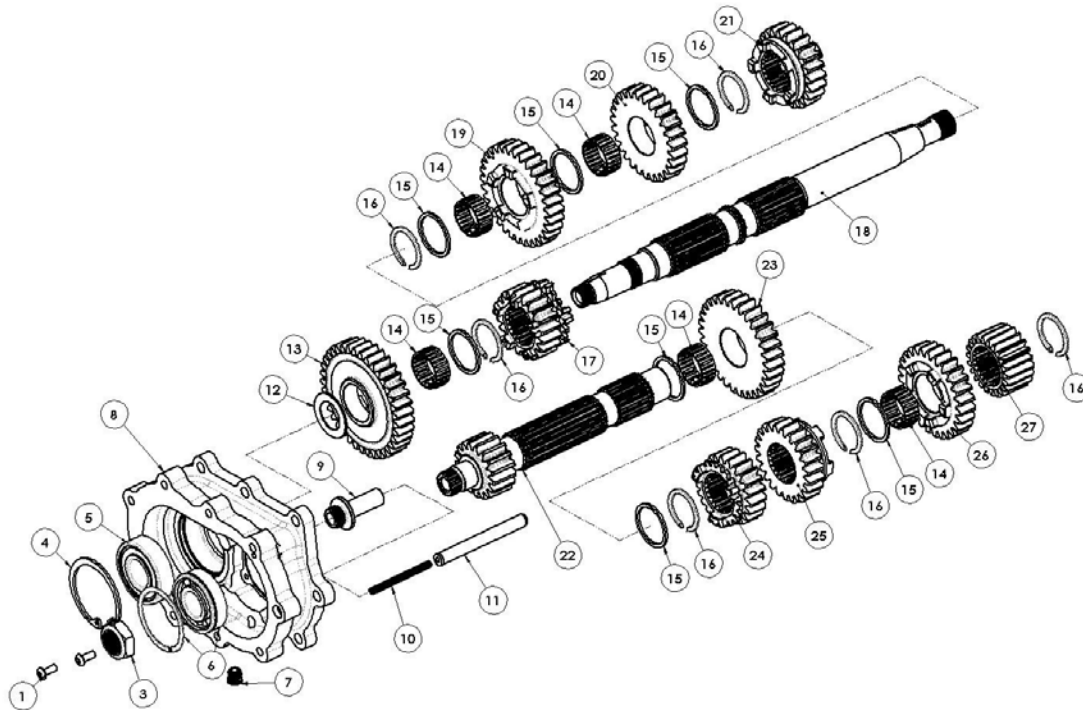

ITEM	QTY	PN	DESCRIPTION
1	2	24040	10-32 x 1/2" BHCS
2	1	37141	3/4-16 Nvloc™ iam nut
3	1	168-6N4	Nut, mainshaft 36-84
4	1	WHM200	Retaining ring, trap door bearing mainshaft
5	1	1640-DSTN	Bearing, trap door mainshaft
6	1	204KG	Bearing, trap door countershaft
7	1	51740-001	Drain Plug
8	1	2-6S	Bearing trap door
9	1	115-6F	Support bridge, auxiliary fork rod
10	1	25287	10-32 x 2 1/4" set screw
11	1	112-6D	Auxiliary fork rod
12	1	TRB1423	Shim spacer
13	1	60866M	6 th gear mainshaft
14	5	8876A	Needle bearing
15	6	6003B	Thrust washer, gearset
16	5	11067	Retaining ring, gearset
17	1	62941MB	1 st gear mainshaft
18	1	MS-6N4-(36,70,84)	Mainshaft ('36-'64,'70-E84, L84)
19	1	61234M	4 th gear mainshaft
20	1	603M2C	3 rd gear mainshaft
21	1	62212M	2 nd gear mainshaft
22	1	CS-6N4	Countershaft
23	1	62941C	1 st gear countershaft
24	1	61234C	4 th gear countershaft
25	1	61573C	3 rd gear countershaft
26	1	603M2C	2 nd gear countershaft
27	1	61005CA	5 th gear countershaft
28	1	TWD324	Trust Washer Bearing

BAKER 6-INTO-4 INSTALLATION INSTRUCTIONS

EXPLODED VIEW: TRANSMISSION CASE

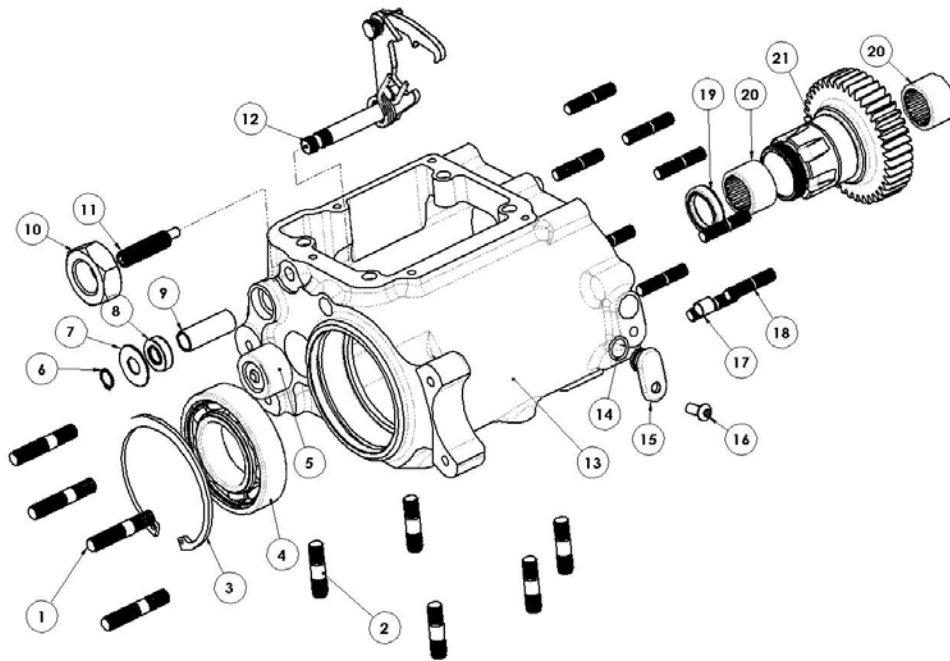

ITEM	QTY	PN	DESCRIPTION
1	4	AV9686Z	Stud, left side of case
2	5	AV9683Z	Stud, case bottom
3	1	1302-334PP	Snap ring, main drive gear
4	1	6209	Bearing, main drive gear
5	1	BK2520	Bearing, left case
6	1	68010	Snap ring, shifter pawl
7	1	6497HW	Washer, shifter pawl
8	1	12045	Seal, shifter pawl
9	1	33114-79	Bushing, shifter pawl
10	1	70813	Jam nut, eccentric screw
11	1	152-56B	Eccentric screw
12	1	555-56C-A	Shifter pawl assembly
13	1	56-1051	Case
14	1	66808	O-ring, speedo sensor plug
15	1	108-6EP	Speedo sensor plug
16	1	73753	¼-20 BHCS, speedo sensor plug
17	2	16583-67	10mm alignment pin
18	9	AV9675Z	Stud, right side of case
19	1	12013C	Seal, main drive gear
20	2	SCE1612	Bearing, main drive gear
21	1	MDG-6N4	Main drive gear

BAKER 6-INTO-4 INSTALLATION INSTRUCTIONS

EXPLODED VIEW: HYDRAULIC SIDE COVER

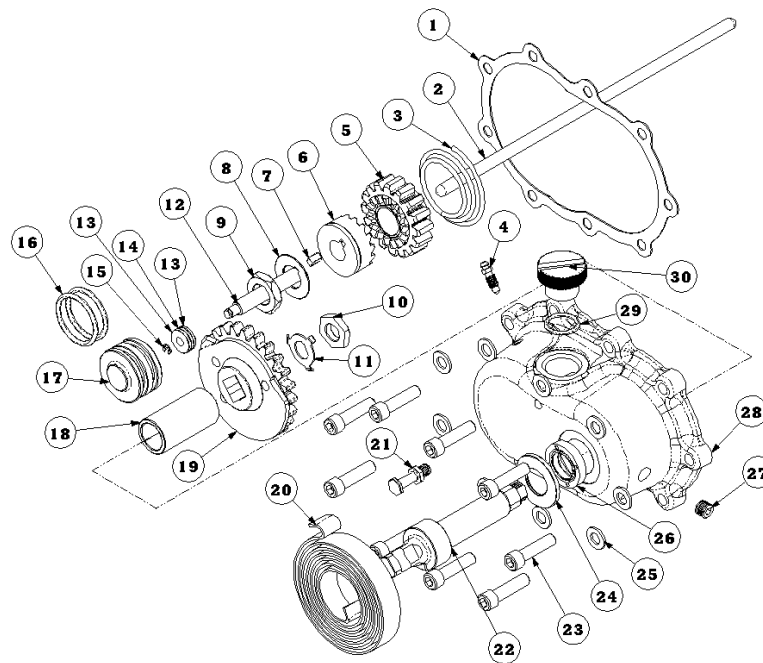

ITEM	QTY	PN	DESCRIPTION
1	1	6N4-SIDE	Gasket, kicker cover
2	1	37088-(90,90E,MOD)	Clutch release rod
3	1	290227	Spring, starter gear
4	1	45-9404	Bleeder screw
5	1	33430-56	Starter gear
6	1	33560-56	Starter clutch
7	1	2213	Key, starter clutch
8	1	290225	Washer
9	1	7071	Nut, starter clutch
10	1	7073	Nut, crank gear
11	1	292014	Washer, crank gear
12	1	37089-84L	Actuator rod
13	2	BD411-56	Washer, actuator rod
14	1	FNT-1024, BD410-56	Thrust bearing, actuator rod
15	1	10705-01149	C-clip, actuator rod
16	2	66855	O-ring, piston
17	1	124-56L	Slave piston
18	1	639K269	Bronze bushing
19	1	33350-56	Crank gear
20	1	291222	Return spring, kicker shaft
21	1	292013	Stud, return spring
22	1	33096-54	Shaft, Crank gear
23	9	31C125KCSS/P	5/16-18 x 1 1/4"
24	1	292016	Washer, crank gear shaft
25	9	6100	Washer, 5/16" AN
26	1	.750x1.250x.250ADL	Seal, crank gear shaft
27	1	51740-001	Level Plug, 3/8-24 Zero leak
28	1	478-56HP	Hydraulic kicker cover
29	1	2418T141	O-ring, filler plug
30	1	292032	Fill plug

BAKER 6-INTO-4 INSTALLATION INSTRUCTIONS

EXPLODED VIEW: FUNCTION FORM HYDRAULIC SIDE COVER

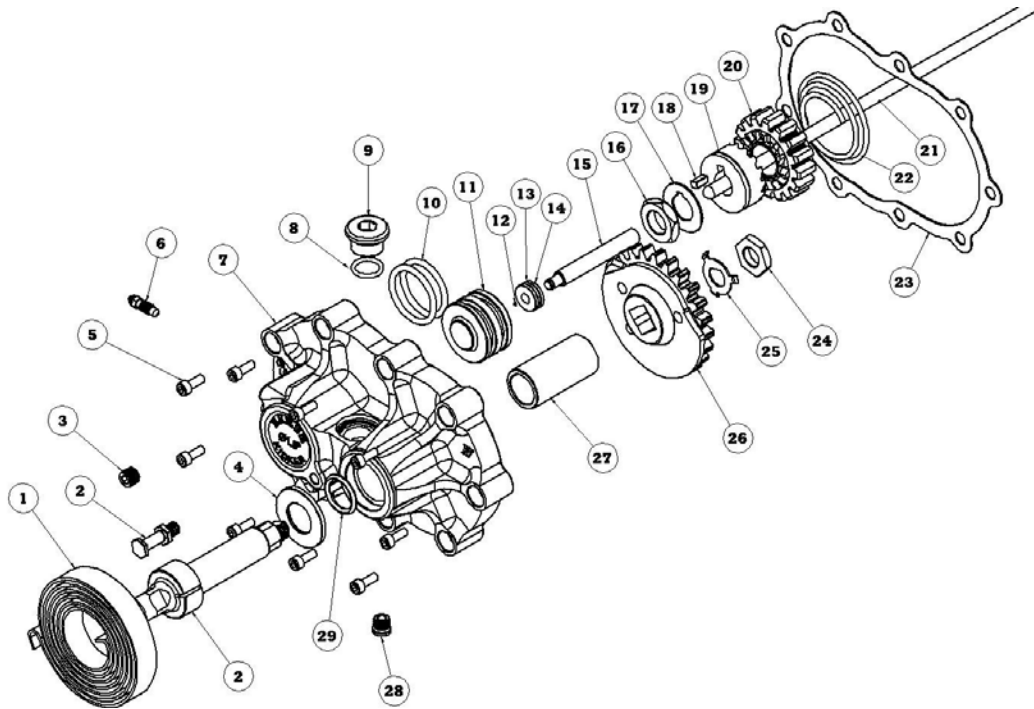

ITEM	QTY	PN	DESCRIPTION
1	1	291222	Return spring, kicker shaft
2	1	292013	Stud, return spring
3	1	51740-001	Level Plug, 3/8-24 Zero leak
4	1	292016	Washer, crank gear shaft
5	9	31C125KCSS/P	5/16-18 x 1 1/4" SHCS SS
6	1	45-9404	Bleeder screw
7	1	479-56-P	Kicker cover, Function Form
8	1	66827	O-ring, filler plug
9	1	130-56FP	Filler plug
10	2	66855	O-ring, hydraulic slave piston
11	1	124-56L	Slave piston
12	1	10705-01149	C-clip, actuator rod
13	1	FNT-1024, BD410-56	Thrust bearing, actuator rod
14	2	BD411-56	Washer, actuator rod
15	1	125-5R	Actuator rod
16	1	7071	Nut, starter clutch
17	1	290225	Washer
18	1	2213	Key, starter clutch
19	1	33560-56	Starter clutch
20	1	33430-56	Starter gear
21	1	37088-(90,90E,MOD)	Clutch release rod
22	1	290227	Spring, starter gear Gasket,
23	1	6N4-SIDE	kicker cover
24	1	7073	Nut, crank gear
25	1	292014	Washer, crank gear
26	1	33350-56	Crank gear
27	1	639K269	Bronze bushing
28	1	51740-001	Level Plug, 3/8-24 Zero leak
29	1	.750x1.250x.250ADL	Seal, crank gear shaft

BAKER 6-INTO-4 INSTALLATION INSTRUCTIONS

EXPLODED VIEW: BILLET MECHANICAL SIDE COVER

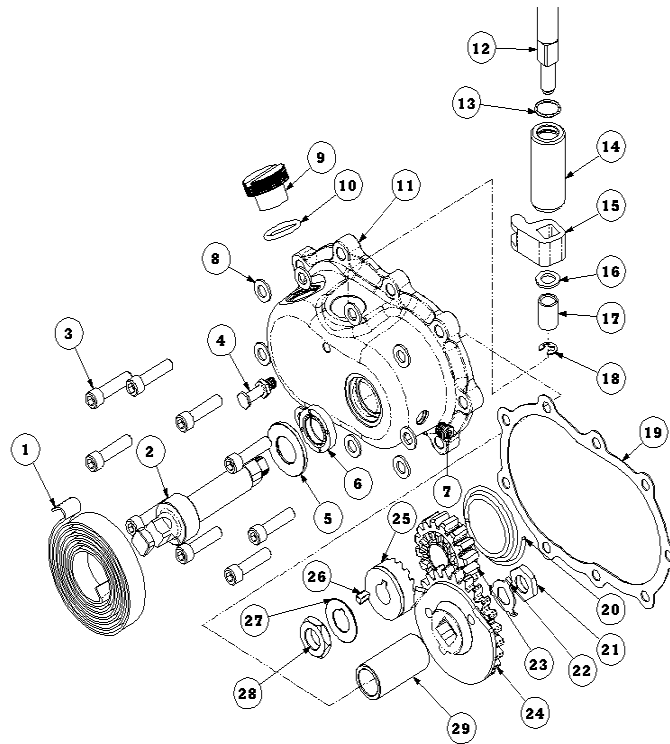

ITEM	QTY	PN	DESCRIPTION
1	1	291222	Return spring, kicker shaft
2	1	33096-54	Shaft, crank gear
3	9	31C125KCSS/P	5/16-18 x 1 1/4" SHCS SS
4	1	292013	Stud, return spring
5	1	292016	Washer, crank gear
6	1	.750x1.250x.250ADL	Seal, crank gear shaft
7	1	51740-001	Level Plug, 3/8-24 Zero leak
8	9	6100	Washer, 5/16" AN
9	1	292032	Filler plug
10	1	2418T141	O-ring, filler plug
11	1	478-56MP	Kicker cover, mechanical
12	1	37074-38C	Release shaft
13	1	66808	O-ring, release shaft
14	1	476-56	Release shaft housing
15	1	37070-39B	Lever, release shaft
16	1	6443HW	Washer, release shaft
17	1	6391K183	Bushing, release shaft
18	1	68077	E-clip, release shaft
19	1	6N4-SIDE	Gasket, side cover
20	1	290227	Spring, starter gear
21	1	7073	Nut, crank gear
22	1	292014	Washer, crank gear
23	1	33430-56	Starter gear
24	1	33350-56	Crank gear
25	1	33560-56	Starter clutch
26	1	2213	Key, starter clutch
27	1	290225	Washer, starter clutch
28	1	7071	Nut, starter clutch
29	1	639K269	Bronze bushing

BAKER 6-INTO-4 INSTALLATION INSTRUCTIONS

EXPLODED VIEW: CABLE TYPE MECHANICAL SIDE COVER

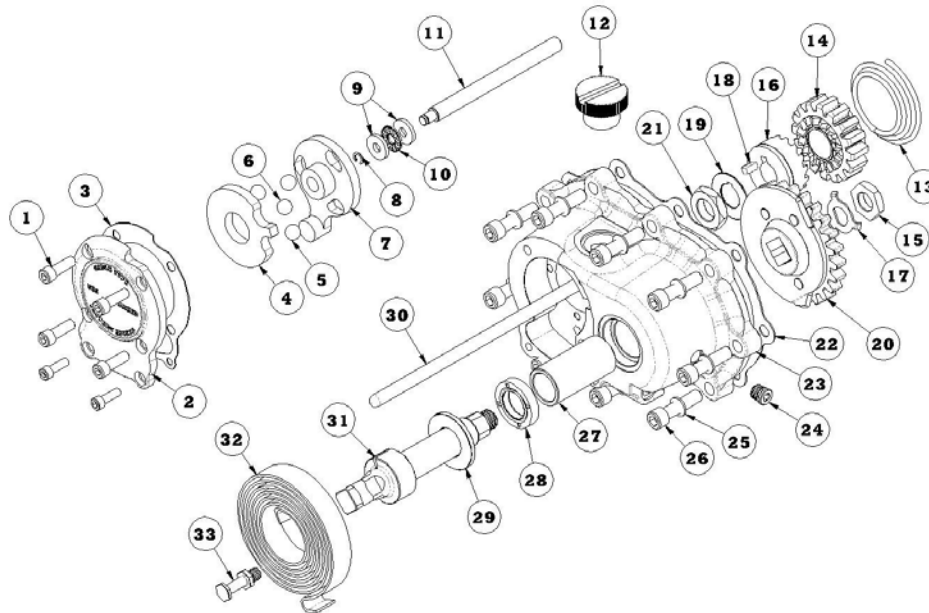

ITEM	QTY	PN	DESCRIPTION
1	6	25C50KLHS	¼-20 x ½" LHCS
2	1	584-56P	Cover, ball and ramp kicker
3	1	587-56	Gasket, ball and ramp kicker
4	1	WT3096B	Inner Ramp, actuator
5	3	987687	3/8" ball bearing, actuator
6	1	3094-DSSC	Actuator ferrule
7	1	WT3196B	Outer ramp, actuator
8	1	10705-01149	C-Clip, actuator rod
9	1	FNT-1024, BD410-56	Washer, actuator rod
10	2	BD411-56	Thrust bearing, actuator rod
11	1	125-5R	Actuator rod
12	1	292032	Filler cap w/o-ring
13	1	290227	Spring, starter gear
14	1	33430-56	Starter gear
15	1	7073	Nut, crank gear
16	1	33560-56	Starter clutch
17	1	292014	Washer, crank gear
18	1	2213	Key, starter clutch
19	1	290225	Washer, starter clutch
20	1	33350-56	Crank gear
21	1	7071	Nut, starter clutch
22	1	6N4-SIDE	Gasket, kicker cover
23	1	578-56MP	Kicker cover, cable type
24	1	51740-001	Level plug, 3/8-24 Zero Leak
25	9	6100	Washer, 5/16" AN
26	9	31C125KCSS/P	5/16-18 x 1 ¼" SHCS SS
27	1	639K269	Bronze bushing
28	1	.750x1.250x.250ADL	Seal, crank gear shaft
29	1	292016	Washer, crank gear shaft
30	1	37088-(90,90E,MOD)	Clutch release rod
31	1	33096-54	Shaft, crank gear
32	1	291222	Return spring, kicker shaft
33	1	292013	Stud, return spring

BAKER 6-INTO-4 INSTALLATION INSTRUCTIONS

Specifications and Torque Values

TRANSMISSION FLUID:

20-24 fluid oz. of Spectro™ Heavy Duty Platinum 6 Speed Transmission Oil (pn BD-75140)

TORQUE VALUES

THREADLOCKER / LUBRICANT

KICKER COVER

- 5/16" Bolts: 200-225 in-lbs (16-18 ft-lbs) Blue thread lock (242 Removable)

KICKER CRANK GEAR

- 42-45 ft-lbs (57-61 Nm) Red thread lock (271 Permanent)

TOP COVER

- 1/4" Bolts: 100-120 in-lbs (8-10 ft-lbs) Blue thread lock (242 Removable)

BEARING TRAP DOOR

- 5/16" Nuts: 200-225 in-lbs (16-18 ft-lbs) Blue thread lock (242 Removable)

MAINSHAFT NUT

- 50-55 ft-lbs (67-75 Nm) Red thread lock (271 Permanent)

RATCHET GEAR NUT

- 50-60 ft-lbs (67-81 Nm) Red thread lock (271 Permanent)

COUNTERSHAFT NUT

- 50-55 ft-lbs (67-75 Nm) Red thread lock (271 Permanent)

FILL PLUG

- 30-40 in-lbs Pipe Thread Sealant

DRAIN PLUG

- 30-40 in-lbs Anti-Seize

SPROCKET NUT

- 60 ft-lbs (81 Nm) initial torque and then turn another 35-45 degrees; 45 degrees max.
Red thread lock (271 Permanent)

BAKER 6-INTO-4 INSTALLATION INSTRUCTIONS

GETTING STARTED

Thank you for buying another premium, American-made innovation from BAKER™ Drivetrain. There are a few important things to know about the BAKER™ 6-into-4 before installing this gem into your bike. Like most BAKER™ innovations, this is an upgrade and not a stock replacement. Because it is not a stock replacement, there are sometimes minor fitment issues you might encounter during the install. The type of fitment issue varies from bike to bike.

The first issue is usually exhaust clearance. The BAKER™ 6-into-4 is 1 5/8" wider than stock, causing it to sometimes interfere with exhaust fitment. There are companies making aftermarket exhaust that will clear the BAKER™ 6-into-4 with no problem. Most stock exhausts do not clear this transmission. This clearance issue is caused because the BAKER™ 6-into-4 has two more gear pairs, which means 50% more transmission in less than 2 inches of more space.

The only other issue that most folks encounter is due to the fact that the BAKER™ 6-into-4 is a direct bolt in, because of the different options on motorcycles there will be individual component clearance issues. This is caused by the vast array of aftermarket parts that have been available during the 50 years that the stock transmission was used. With varying individual components bike to bike, BAKER™ cannot guarantee individual component clearance. We can however, guarantee our 6-into-4 you're about to slam in there, so we offer an incredible 5yr, 50k mile warranty on it and you can read all about that in the back of these instructions.

Remember, BAKER™ Drivetrain is always standing by with knowledgeable tech support if you should encounter any issues during your install.

BAKER 6INTO4 INSTALLATION INSTRUCTIONS

TOOLS, RESOURCES, REQUIRED PARTS

- Factory Service Manual For Your Motorcycle
- Factory Parts Manual For Your Motorcycle
- H-D™ Clutch hub puller hand tool
- Common American sockets and open end wrenches
- Impact Driver
- Torque Wrench (reads both in inch pounds and foot pounds)
- Brake Bleeder Pump (for hydraulic type)

NOTES: HYDRAULIC VERSION ONLY

To complete the Installation of the hydraulic kicker 6-INTO-4, the following parts will have to be procured to complete the job:

- Hydraulic Fluid, BAKER™ Recommends: H-D™ Dot 5 Brake Fluid, PN 99902-77
- Correct length AN -3 Brake Line
- 10mm Banjo Fitting & Washers For Both Ends Of Brake Line
- 3/8"-24 Banjo Bolt For The Side Cover End Of The Brake Line
- 11/16" Diameter Bore Hydraulic Clutch Lever Assembly or H-D™ Assembly

BAKER 6INTO4 INSTALLATION INSTRUCTIONS

TRANSMISSION INSTALLATION:

1936-1964 MODELS:

We recommend installing the transmission per your factory service model. If you have ordered the 6-into-4 with the 1936-1964 mainshaft; the dust shield splash guard will need to be modified to clear the splines of the output gear. This application is recommended for use with tin primaries. Stock exhaust will not fit. Your exhaust will either need to be modified or an aftermarket exhaust will need to be installed.

1965-69 MODELS:

BAKER 6-into-4 Speeds utilize an early 5 speed spline design for the main drive gear. Using this design requires a slightly offset sprocket to wrap around the modern spacer and drive gear. On 1965-69 models the stock inner primary has a lip which will hit the sprocket before going onto the transmission all of the way. Following these instructions and images, modify your stock H-D primary for proper fitment. These instructions do not apply for aftermarket inner primaries or belt drive motor plates.

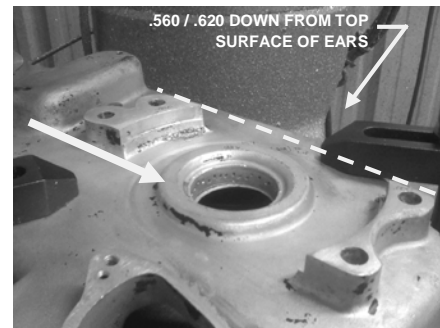

STOCK 65 INNER | FIGURE 11

Modification of stock 65-69 inner primary

- Looking at figure 11 you can see the inner lip that has to be machined down in order to clear the sprocket and sprocket nut.
- Machine down this lip; measuring from the ears on the primary down; finish machine should be: .560" / .620" from the ear surface, figure 11. Notice that the threaded holes are now exposed on the casting from machining, figure 12.
- Chamfer the inner primary ears on the inside edge, breaking the edge .020/.030 X 45, figure 12.



MODIFIED 65 INNER | FIGURE 12

BAKER 6-INTO-4 INSTALLATION INSTRUCTIONS

Make sure to test fit the primary onto the transmission before running. Extra machining clearance might be needed for proper fitment.

- After making sure everything fits properly, using four 1/4-20 X .375" set screws plug off the threaded holes. Apply some pipe thread sealant on the set screws then install from the inside, figure 13
- Install the primary per your Factory Service Manual.

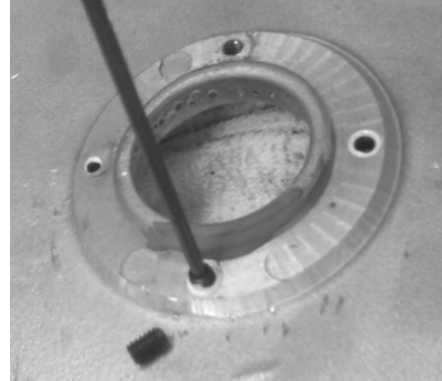

1970-E1984 MODELS – WITH OR WITHOUT ELECTRIC START:

Mount the transmission to the transmission plate per your factory service manual.

Now mock up the primary onto the transmission (with the sprocket installed) and make sure there are no clearance issues.

If you are not running an inner primary bearing, we recommend installing our optional bearing support (pn 6-4SSP-A) with the 70-E84 or late 84 shafts.

For models with an oil tank bracket that runs to the transmission, you will need to fabricate up a new 'Z' bracket to accommodate the wider transmission.

1984-1986 MODELS-WITH BELT DRIVE SECONDARY:

The splines on the main drive gear of the 6-into-4 are comparable to a 1982-1984 FXR™. The key way is of a 1984-1989 5 speed and or 1984-1986 4speed.

Belt drive final drive bikes, you must use our 33 tooth pulley (pn32181S). The BAKER™ main drive gear is longer and the bearing and seal system is updated from your OEM H-D™ main drive gear. If you attempt to use the OEM pulley there will be almost a ¼ inch off interference from the pulley to inner primary. The factory pulley measures 1.941" wide. The BAKER™ pulley measures 1.600" wide. The back spacing is different as well as the length of our main drive gear and sprocket spacer.

**ALL YEARS:

You must use the supplied 3/8-24 (pn37090-6-4) and seal (pn.3125x.875x.250) in the stock clutch nut. For aftermarket clutches with 7/16" adjuster screws you must order adjuster screw pn 37091-6-4 and lock nut (pn36258).

BAKER 6INTO4 INSTALLATION INSTRUCTIONS

TERMS:

SPECIAL ORDERS

A minimum \$500 deposit is required with all special orders. Special orders include unique case finishes, unique side door requests (i.e.; wrinkle black door or no logo).

ALL OTHER ORDERS

Orders can be pre-paid using VISA, MasterCard or American Express.

Prices shown are F.O.B. Haslett; MI. BAKER™ provides free UPS ground shipping on all retail orders for complete transmissions or transmission kit. UPS air shipment is available upon request. Customer is responsible for air shipment premiums.

LIMITED WARRANTY

BAKER™ 6-INTO-4 transmissions are guaranteed to the original purchaser to be free of manufacturing defects in materials and workmanship for a period of 5 years or 50,000 miles from the date of purchase whichever comes first

If the product is found by BAKER™ to be defective, such products will, at the option of BAKER™, be replaced or repaired at cost to BAKER™.

In the event warranty service is required, the original purchaser must call or write BAKER™ immediately with the problem. If it is deemed necessary for BAKER™ to make an evaluation to determine whether the transmission assembly or transmission kit is defective, the entire transmission assembly, whether originally purchased as an assembly or kit, must be properly packaged and returned prepaid to BAKER™ with a copy of the original invoice of purchase.

If after an evaluation has been made by BAKER™ and a defect in materials and/or workmanship is found, BAKER™ will, at BAKER™ option, repair or replace the defective part of the assembly.

Warranty card must be returned within 45 days of purchase to be valid.

ADDITIONAL WARRANTY PROVISIONS

This limited warranty does not cover labor or other costs or expenses incidental to the repair and or replacement of BAKER™ products. This warranty does not apply if one or more of the following situations is judged by BAKER™ to be relevant: improper installation, accident, modification (including but not limited to use of unauthorized parts), racing, high performance application, mishandling, misapplication, neglect (including but not limited to improper maintenance), or improper repair.

BAKER™ shall not be liable for any consequential or incidental damages arising out of or in connection with a BAKER™ transmission assembly, transmission kit, swingarm, fender, component or part. Consequential damages shall include without limitation, loss of use, income or profit, or losses sustained as the result of injury (including death) to any person or loss of or damage to property.

BAKER™ transmissions, transmission kits, and Wide Tire Kits are designed exclusively for use in Harley-Davidson® motorcycles. BAKER™ shall have no warranty or liability obligation if a BAKER™ part is used in any other application.

BAKER 6INTO4 INSTALLATION INSTRUCTIONS

DISCLAIMER

The words Harley™ and H-D™ are registered trademarks and are for reference only. Use of H-D™ model designations and part numbers are for reference only. BAKER™ Drivetrain has no association with, and makes no claim against, these words, trademarks, or companies.

It is the sole responsibility of the user to determine the suitability of this product for his or her use, and the user shall assume all legal, personal injury risk and liability and all other as well as all other obligations, duties and risks associated therewith.

