

BADLANDS LE-03 Load Equalizer Modules

Thank you for purchasing a Badlands Load Equalizer Module! We're sure that you will be completely satisfied with the performance and ease of installation of your new module. Before you get started, PLEASE read these instructions and helpful tips so that you understand how to install your module correctly. An improper installation will void the warranty.

FEATURES: All Badlands Load Equalizer Modules are designed to provide you the ability to use small incandescent bulbs, Halogen bulbs or LED style (*module operates both front & rear*) turn signals without a rapid flash. **(INSTALL OUR MODULE BEFORE YOU INSTALL YOUR NEW LIGHTS!)** A "rapid-flash" is caused by the factory turn signal module not seeing the specific amperage draw that the factory installed 1156/1157 bulbs provided. Whether you have a Plug-n-Play module or the hard-wired version, Load Equalizer Modules all work the same. Now you understand the features of our Load Equalizer Module, let's talk about how it works.

PLUG-N-PLAY INSTALLATION: Most of our modules offer Plug-n-Play technology, making installation quick and easy. Simply remove your seat or left side cover on FL Models, unplug the **rear fender harness** connectors, plug our module in between and you're done.

HARD-WIRED INSTALLATION: On the hard-wired modules, you can use any installation method you choose but **DISCONNECT** the battery **FIRST!** We package this version with (1) ring terminal and quick splices but we recommend using connectors and terminals whenever possible. Now let's talk about connecting the wires. As you can see in the drawing below, it is easiest to install the LE-03 near or at the rear fender harness connection. The rear fender harness should ALWAYS have the following wires in it; running light, brake light, ground, left turn signal and right turn signal. On 1996-2013 models, use the supplied quick splices to "splice" into the LEFT TURN signal wire (VIOLET) and the RIGHT TURN signal wire (BROWN). On pre-'96 models, the wire colors will be different so be sure to consult your bikes service manual for exact wiring diagrams and color descriptions to achieve proper installation. The diagram below shows you to "splice into" these (2) wires while still keeping the wires connected as they were from the factory. Be sure to connect the ORANGE/WHITE (*with a 7.5 AMP fuse*) and BLACK wires to the directly to the battery as shown to prevent "bleed" or radio interference.

LE-03: Hard-wired super module, universal fitment on 1991 - 2013 models, comes complete with (1) 1/4" ring terminal for the BLACK wire to be connected directly to battery post or frame ground, (3) quick splices for ORANGE (*we strongly recommend going directly to the battery using a 7.5 AMP fuse*), VIOLET and BROWN turn signal input wires on the module.

LE-03-A: Plug-n-Play module, fits ('96-'13 FLH, (except '10-Up Street & Road Glides) all '97-'13 FX & Dyna (except Rocker) and XL models '99-'03)

LE-03-C: Plug-n-Play module, fits ('04-'13 XL ONLY.)

LE-03-R: Plug-n-Play module, fits (All Rocker models)

LE-03-SR: Plug-n-Play module, fits ('10-'13 Street Glides and Road Glides ONLY.)

LE-03-SRCVO: Plug-n-Play module, fits ('09-'13 FLH CVO & Screaming Eagle ONLY.)

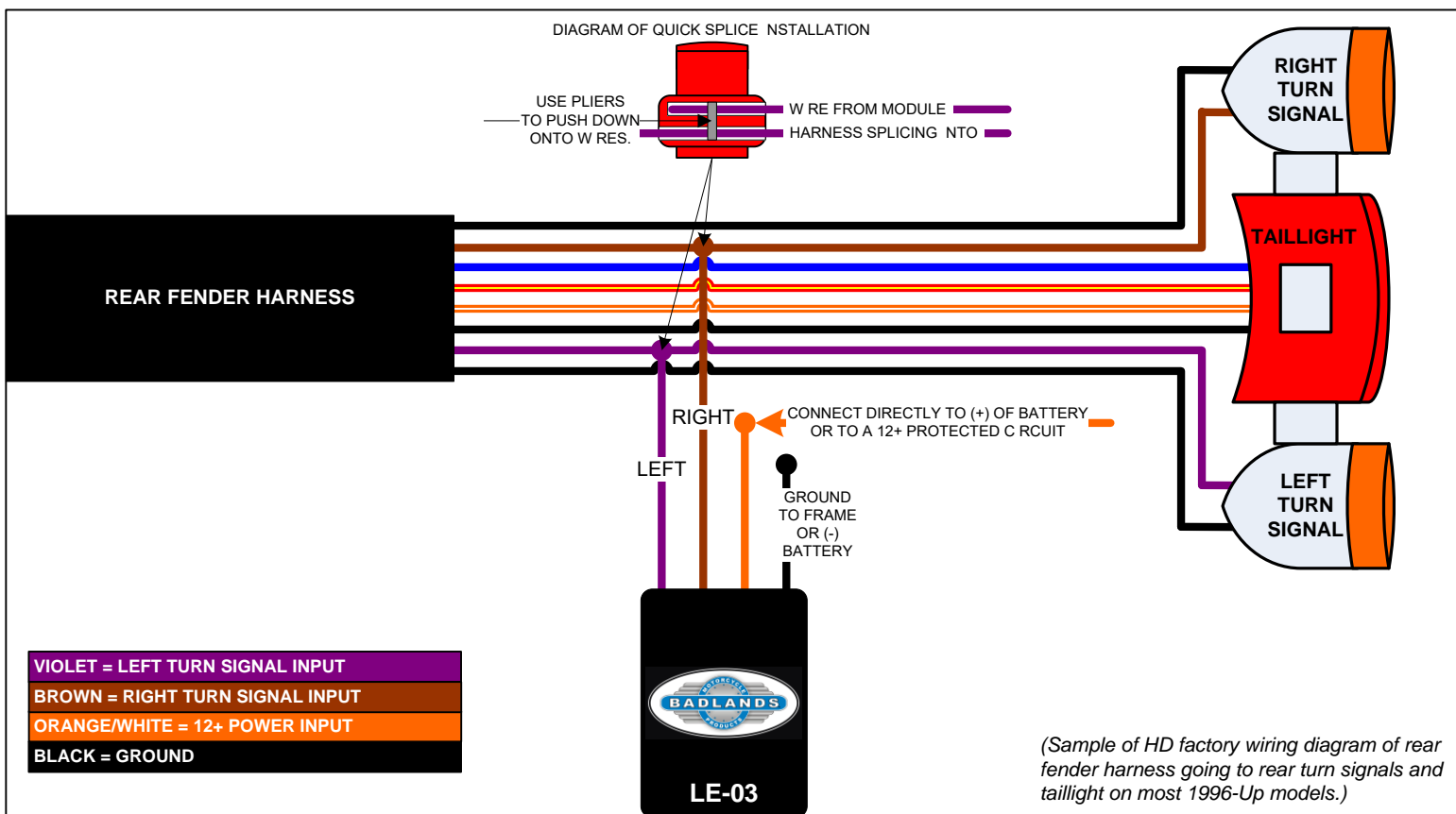

BADLANDS LE-01 and LE-02 Load Equalizer Modules

Thank you for purchasing a Badlands Load Equalizer Module! We're sure that you will be completely satisfied with the performance and ease of installation of your new module. Before you get started, PLEASE read these instructions and helpful tips so that you understand how to install your module correctly. An improper installation will void the warranty.

FEATURES: All Badlands Load Equalizer Modules are designed to provide you the ability to use small incandescent bulbs, Halogen bulbs or LED style turn (*module operates both front & rear*) signals without a rapid flash. **(INSTALL OUR MODULE BEFORE YOU INSTALL YOUR NEW LIGHTS)** A "rapid-flash" is caused by the factory turn signal module not seeing the specific amperage draw that the factory installed 1156/1157 bulbs provided. Whether you have a Plug-n-Play module or the hard-wired version, Load Equalizer Modules all work the same. Now you understand the features of our Load Equalizer Module, let's talk about how it works.

INSTALLATION: You can use any installation method you choose but **DO NOT** disconnect the battery! We package these versions with (1) ring terminal and (2) quick splices but we recommend using connectors and terminals whenever possible. Now lets talk about connecting the wires. As you can see in the drawing below, it is easiest to install the LE-01 and LE-02 near or at the rear fender harness connection. The rear fender harness should ALWAYS have the following wires in it; running light, brake light, ground, left turn signal and right turn signal. On 1996-Up models, use the supplied quick splices to "splice" into the LEFT TURN signal wire (VIOLET) and the RIGHT TURN signal wire (BROWN). On pre-'96 models, the wire colors will be different so be sure to consult your bikes service manual for exact wiring diagrams and color descriptions to achieve proper installation. The diagram below shows you to "splice into" these (2) wires while still keeping the wires connected as they were from the factory. Be sure to connect the BLACK wire to the directly to the battery as shown or a good frame ground.

LE-01: Hard-wired economy module, universal fitment on 1991 - 1999 models, comes complete with (1) 1/4" ring terminal for the BLACK wire to be connected directly to battery post or frame ground and (2) quick splices for VIOLET and BROWN, (*LE-01*) turn signal input wires on the module.

NOTE: The LE-01 Module will PRODUCE HEAT like most electrical devices so use caution when mounting the module close to wire looms or plastics. This low cost module is recommended for **LIGHT** usage and will allow EXTREMELY LIMITED USAGE of the 4-way safety flashers when pulling over for emergency purposes only. **Never** operate in parade mode using this module.

LE-02: Hard-wired premium module, universal fitment on 1991 - 1999 models, comes complete with (1) 1/4" ring terminal for the BLACK wire to be connected directly to battery post or frame ground and (2) quick splices for VIOLET and BLUE, (*LE-02*) turn signal input wires on the module.

NOTE: The LE-02 Module will PRODUCE HEAT like most electrical devices so use caution when mounting the module close to wire looms or plastics. This low cost module is recommended for **MEDIUM** usage and will allow VERY LIMITED USAGE of the 4-way safety flashers when pulling over for emergency purposes only. **Never** operate in parade mode using this module.

There is **NO** warranty WHATSOEVER on either the LE-01 or LE-02 Modules. The manufacturer nor the seller assumes any responsibility or liability for damage caused by inappropriate use by the consumer/operator or installer.

