

BADLANDS ATS-03 11-Second Self Canceling Module with built in LOAD EQUALIZER

Thank you for purchasing a Badlands ATS-03 Module! We're sure that you will be completely satisfied with the performance and ease of installation of your new module. Before you get started, PLEASE read these instructions and helpful tips so that you understand how to install your module correctly. An improper installation will void the warranty.

FEATURES: All Badlands ATS-03 Self Canceling Modules are designed to provide a less expensive alternative to the factory flasher module. The ATS-03 module not only has a built in 11-second flasher but it also is a Load Equalizer which allows you to use small incandescent bulbs, halogen bulbs or LED's without any rapid-flashing issues. The ATS-03 also has a 4-way flasher feature for safety or parade mode just like the factory flasher unit. Whether you have a Plug-n-Play module or the hard-wired version, ATS-03 Modules all work the same. Now you understand the features of our ATS-03 Module, let's talk about how it works.

WIRING OF NON PLUG-N-PLAY MODULES ONLY: The wiring colors on our ATS-03 Modules are defined in the color chart below. The RED/YELLOW wire on the our module needs 12-volt switched (*when the key is on*) power from a protected source like a circuit breaker or fuse. The BLACK wire should be attached to the frame or ground directly to the (-) side of the battery.

PLUG-N-PLAY INSTALLATION: Most of our modules offer Plug-n-Play technology, making installation quick and easy. Simply remove your defective factory flasher module, re-connect the bike harness into our module and you're done. Your ATS-03 Module will give you self-canceling turn signals that last 11-seconds before they shut off automatically. If you need more than 11-seconds of flashing, simply press the signal button again. (*see back for fitment*)

HARD-WIRED INSTALLATION: On the hard-wired version, you can use any installation method you choose but **DISCONNECT** the battery **FIRST!** We package this version with butt connectors and Scotch locks but we recommend using connectors and terminals whenever possible. Now lets talk about the input and output wires. When we say "INPUT" we are referring to the VIOLET and BROWN wires attached to our module. These need to be connected to the OUTPUT of your left and right turn signal switch buttons as described in the drawing below. Once hooked up, (see wiring diagram below) the input wires will provide the signal needed for the ATS-03 Module to process left and right (11-seconds long) turn signal flashing. This module is more custom than others and requires planning. Use the diagram below to understand how to install the module on your custom bike. It gives you a good idea on what and how many wires need to be run to front and rear turn signals and indicator lights if used. The YELLOW wire is RIGHT signal output and the GRAY wire is LEFT signal output. Some turn signals ground themselves when bolted onto the bike so if there is not a ground wire attached, be sure to mount your lights to metal and verify that it has a good ground. Use a multi-meter to test the ground before powering up the module.

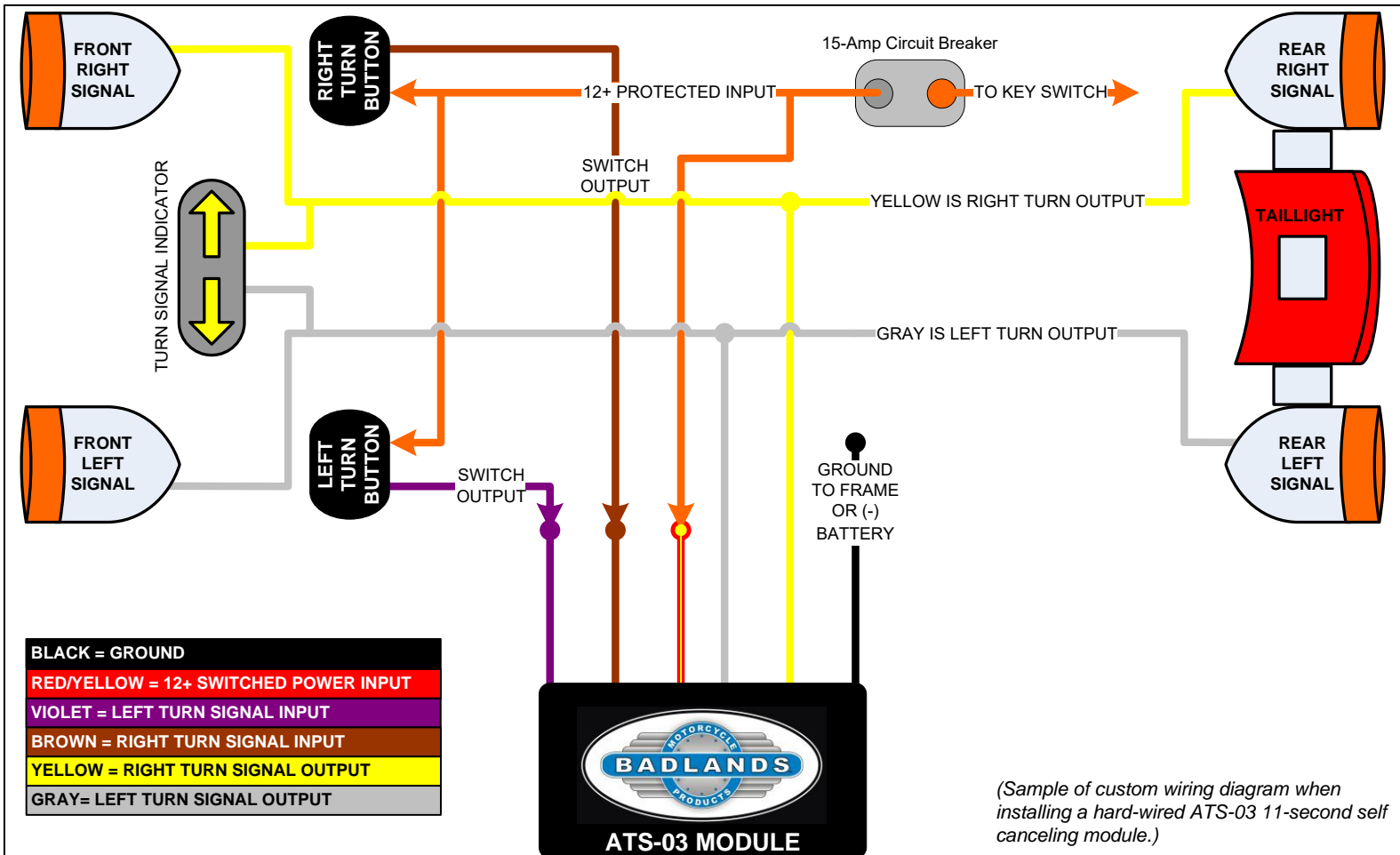

The wire colors in the drawing are used for reference only based on the colors we use on our module. When installing the hard-wired AT5-03 on a factory model, be sure to consult your bikes service manual for exact wiring diagrams and color descriptions to achieve proper installation.

FITMENT: Here is the list of Badlands Automatic Turn Signal Self Canceling Modules and the fitment description for each part number.

AT5-03: Hard-wired module, universal fitment, comes complete with (1) 1/4" ring terminal for the BLACK wire to ground to the frame or directly to the battery post, (1) quick splices (*or butt connector*) for RED/YELLOW wire on the module for 12+ volt switched power and (5) butt connectors for right and left turn signal inputs and outputs.

AT5-03-A: Plug-n-Play module, fits ('87- '93 FLH, '90-'93 FX, '92 & '93 XL) This module comes with a 6-position male OEM Mate-n-Lock connector that plugs directly into factory wiring harness in place of the factory flasher module.

AT5-03-B: Plug-n-Play module, fits (all '94 - '99/2000 models (Until Delphi TSM system.) This module comes with an 8-position male OEM Deutsch connector that plugs directly into factory wiring harness in place of the factory flasher module.

AT5-03-C: Plug-n-Play module, fits (all '94 - '99/2000 models (Until Delphi TSM system.) This module comes with a 12-position male OEM Deutsch connector that plugs directly into factory wiring harness in place of the factory flasher module.