

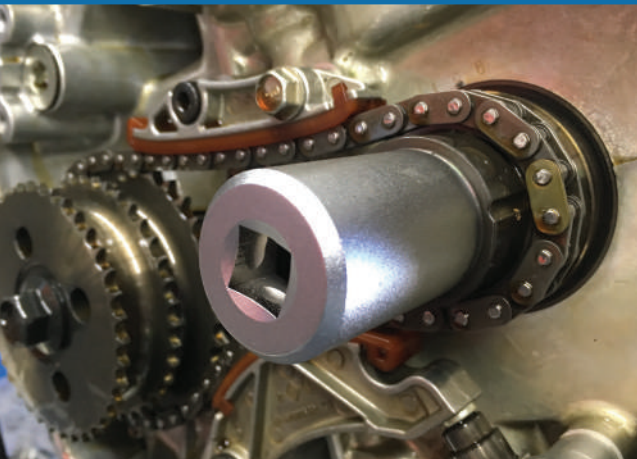

ASSENMACHER[®] SPECIALTY TOOLS

CELEBRATING 40 YEARS | 1978-2018



PRODUCT CATALOG | 2019 - 2020



ASSENMACHER[®]
SPECIALTY TOOLS[®]

About Our Company

We manufacture and distribute a full line of specialty tools, cooling system adapters, oil change products, cam alignment tools and disconnect tools for Asian, Domestic and European vehicles. Located in Boulder, Colorado, AST was founded in 1978 by Gerhard Assenmacher and has remained at the forefront of independently owned tool companies since our beginning. Many decades of hands-on industry experience is what makes our team stand above the rest. We build relationships, we know our customers and we know our products. We take pride in the fact that our customers can simply pick up the phone and we are there to help—that's the personal service you'll find at AST.



Many products from AST are Made in the U.S.A. — including our Cooling System Adapters, Engine Oil Funnels and many Special application tools.

Those that work in U.S. manufacturing are consumers in our local states and cities. If these people continue to manufacture goods, they will continue to make local purchases and support their local economies. As long as businesses thrive, they will require goods and services that meet their daily needs. Independence as a society requires the skill, ability and knowledge to make things ourselves.



TOOLS FOR
ASIAN MODELS **7-20**

ACURA / HONDA	8-9
HYUNDAI / KIA	10
MAZDA	11-12
NISSAN / INFINITI	13-14
LEXUS / SCION / TOYOTA	15-17
SUBARU	18-20

TOOLS FOR
DOMESTIC MODELS **21-32**

CHRYSLER / DODGE / JEEP / RAM	22-24
FORD	25-30
GENERAL MOTORS	31-32
TESLA	107

TOOLS FOR
EUROPEAN MODELS **33-72**

BMW / MINI	34-46
JAGUAR / LAND ROVER	47-49
MERCEDES	50-54
VOLVO	55-56
VW / AUDI / PORSCHE	57-72

TOOLS FOR
HEAVY TRUCK **73-77**

CUMMINS / DETROIT DIESEL / FREIGHTLINER / INTERNATIONAL / MACK / VOLVO	73-77
--	-------

TOOLS LISTED BY
SPECIALTY AND APPLICATION **78-123**

PLIERS	80
GENERAL TOOLS	81-83
FLUID EXCHANGE	84-87
FUNNELS	88-91
OIL FILTER SOCKETS & WRENCHES	92-94
DIPSTICKS / OIL & TRANSMISSION	95
SPECIALTY SOCKETS	96-101
STUD PULLERS	102-103
BODY / RADIO / ELECTRICAL	104-105
MOTORCYCLE / ATV / MARINE	106
ELECTRIC / HYBRID VEHICLES	107-108

APPENDIX **109-123**

APPLICATION CHARTS	108-124
CALIFORNIA PROP 65 WARNINGS	125

TOOL INDEX **126**



Made in the USA



Made in Germany

Copyright© 2019 Assenmacher Specialty Tools®, Inc.

All Rights Reserved. No part of this catalog covered by the copyrights herein may be reproduced or copied in any form or by any means—graphic, electronic or mechanical, including photocopying, taping, or information storage and retrieval systems—without written permission from Assenmacher Specialty Tools®.

Exact product specifications may vary depending upon date of purchase and / or date of manufacture. In order to provide a cost efficient tool with superior quality, AST manufactures many tools in the U.S., some overseas & some are imported from Germany.

Printed in the USA on paper made in the USA!

Acura, Audi, BMW, Cadillac, Chevrolet, Chrysler, Cummins, Detroit Diesel, Dodge, Ford, GMC, Honda, Hyundai, Infiniti, Jaguar, Jeep, Kia, Land Rover, Lexus, Mazda, Mercedes, Mini, Nissan, Porsche, Ram, Scion, Subaru, Tesla, Toyota, Volkswagen and Volvo are all registered trademarks.

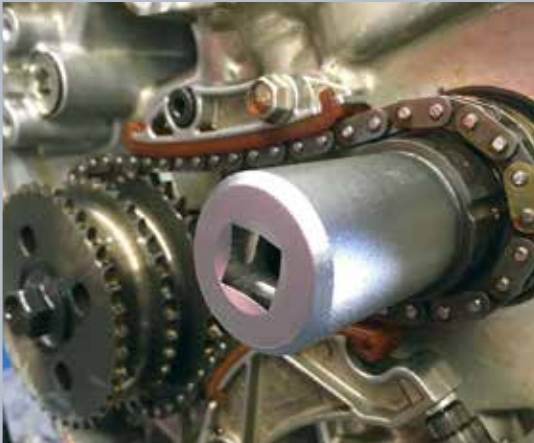

TOOLS FOR
ASIAN MODELS

7-20

ACURA / HONDA 8-9

HYUNDAI / KIA 10

MAZDA 11-12

NISSAN / INFINITI 13-14

LEXUS / SCION / TOYOTA 15-17

SUBARU 18-20



#HON37517
Serpentine Belt Wrench



Serpentine belt wrench equipped with dual 17mm 12-point sockets. One side a shallow, secured 17mm, 12-point and the other a 3/8" drive with removable long 17mm, 12-point for engagement every 30 degrees. Applicable: Acura MDX [2014-2016], Honda Accord 4-cyl. [2014], CR-V [2015-2016], Crosstour [2014-2015], Odyssey [2016-2018] and Pilot [2016].

#HON1419
Serpentine Belt Wrench



Serpentine belt wrench equipped with 14mm and 19mm, 12-point secured sockets, for engagement every 30 degrees. Ideal for strong tensioner's used on Honda Accord [2006], Civic [2006-newer], Odyssey and Pilot.

- For newer Honda models, see #HON37517.

#FZ13818
Tank Adapter



Used for pressurizing cooling system. For Honda models with small, shallow necks. Applicable to Acura MDX [2018]; Honda Accord [1994-2016], Civic [1994-2015], Clarity [2018], CR-V [2014-2016], Element [2008], Odyssey [1999-2018], Pilot [2003-2016] and S2000 [2008].



#HONBC26
Brake Fluid Adapter



Used in conjunction with pressure bleeder. 1/4-18 NPT fitting is not included. Applicable: Honda Accord, Civic, Odyssey and Pilot.



#OFHON1033
Engine Oil Funnel



Threads on and seals to the valve cover, just like the oil cap. Prevents unwanted messes. Applicable to Acura models [2000-2018]; Honda Accord, Civic, CR-V, Element, Fit, HR-V, Insight, Odyssey, Pilot and S2000 [1998-2018]. For V6 motors in Honda SUVs and Odyssey, use #OFH33 or #OFA33 with #OFHON1033.

- DO NOT USE BRAKE CLEAN

 California Residents: Proposition 65 WARNING. See page 125 for info.



#3035
3.5mm Socket

Used for R & R of the Proximity (Radar) Sensors and any place a 3.5mm socket is needed.

- 1/4" Drive
- 25mm Length



#JAS6514
Oil Filter Wrench

Applicable to various Honda models [1987-2018] and Honda Powersports vehicles that utilize "HF303" oil filters.

- 65mm - 14 Flats
- 3/8" Drive



#HO10PT
10-Point Socket

Applicable to Acura RSX and Honda Civic [2001-2006] rear lower control arms.

- 16mm
- 1/2" Drive
- 40mm Length



#OFH33
Funnel Extension



Oil funnel extension for #OFHON1033 and OFHON33 oil funnels. Adds coverage and access where normal funnels do not fit. Applicable to ACURA MDX, ZDX; Honda Odyssey, Pilot, and Ridgeline.

- DO NOT USE BRAKE CLEAN

NOTE: USED IN CONJUNCTION WITH #OFHON1033 OR #OFHON33 FUNNEL.

 California Residents: Proposition 65 WARNING. See page 125 for info.



#TM12125
Ball Joint Hammer Nut

NEW!

Used for breaking free steering knuckle/suspension joints using an impact hammer. Nut must be threaded all the way onto knuckle/suspension joints threaded shafts.

- M12 x 1.25 Threads
- 22mm - 7/8" Hex



NOTE: FOR THE COMPLETE 4PC. SET, PURCHASE THE #TM20194 CONTAINING M12X1.25, M12X1.5, M14X1.5 AND M16X1.5.

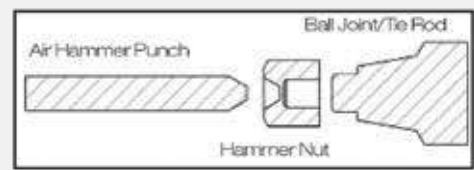

#OFGMRD08
Engine Oil Funnel



Attaches directly to the engine oil filler neck. Applicable to Hyundai Santa Fe 2.4L [2001–2006], Sonata [2002–2005], Tiburon [2006–2010] and Tucson [2004–2010].

- DO NOT USE BRAKE CLEAN
- Made of strong polycarbonate
- No more messes

California Residents: Proposition 65
WARNING. See page 125 for info.

#OFHD35
Engine Oil Funnel



Oil funnel threads on and seals. Applicable to Kia Forte [2013–2018], Optima [2016–2018], Rio [2013–2018], Sedona [2015–2018], Sorento [2011–2016], Soul [2013–2018] and Sportage [2014–2018].

- DO NOT USE BRAKE CLEAN

California Residents: Proposition 65
WARNING. See page 125 for info.



#2127
Oil Filter Socket

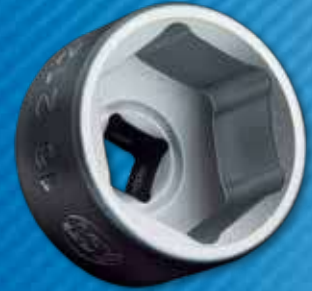

Used on various Hyundai and Kia models. Applicable to Hyundai Azera [2009–2012], Equus [2011–2013], Genesis [2008–2013], Santa Fe 3.3L [2009], Sonata 3.3L [2009], Veracruz [2007–2013]; Kia Amanti [2007–2009], Borrego [2009–2012], Cadenza [2014–2018], Sedona [2016–2018] and Sorento [2007–2018].

- 27mm - 6 Flats
- 3/8" Drive

#SU8015
Oil Filter Wrench

Applicable to Hyundai S Coupe [1992–1994], Accent [1995–2013], Elantra [1992–2013], Excel [1986–1994], Genesis Coupe 2.0L [2008–2012], Santa Fe [2000–2009], Sonata [1992–2012], Tiburon [2001–2008], Tucson [2004–2012], Veloster [2011–2013], XG300 [2000–2005], XG350 [2000–2005]; KIA Amanti [2004–2006], Forte [2010–2018], Niro [2017–2018], Optima [2001–2018], Rio [2006–2018], Rondo [2007–2009], Sorento [2003–2018], Soul [2010–2018], Spectra [2004–2009] and Sportage [2005–2018].

- 80mm - 15 Flats
- 3/8" Drive



#ATFSU100
Universal ATF Attachment



Used with our ATF driveline filler. This flexible adapter is used to fit into hard to reach applications where there is at least a 10mm internal diameter opening to fit into. Great for automatic transmission fill on Kia models with restricted access to transmission fill tube.

#6300T-50
Torx Socket

NEW!

Used in conjunction with #ALT34018 on KIA Alternator Pulley Bolts.

- T-50
- 3/8" Drive
- 70mm Length



#ALT34018
Alternator Pulley Socket

NEW!

Used for R and R of the free-wheel pulley on the alternator on Bosch Alternators. Used in conjunction with #6300T-50.



#FM2303
Crank Locking Pin



Applicable to Mazda Tribute [2001–2004]. Used in conjunction with #FM2330 Mazda timing set.
COMPARABLE: #303-574

#FM2330
3-Piece Timing Set



Used on all Mazda 2.0L MZR, 2.3L (turbo and naturally aspirated) and 2.5L engines. *[2004-older] 2.0L engines use the FM 2303 crank pin. Applicable to Mazda 3 [2004-2013], 5 [2006-2013], 6 [2003-2013], 7 [2007-2012], Mazdaspeed 3 [2007-2013], Mazdaspeed 6 [2006-2007], and MX-5 Miata [2006-2013].

COMPARABLE: #303-507, #303-465 AND #303-1061.

#FZ13818
Radiator Adapter



For pressurizing cooling system. Applicable to Mazda 5 [2007], Protege (manual) [2000–2001], Protege 5 [2003].



#FZ47
Tank Adapter



For pressurizing the cooling system. Applicable to Mazda 3 [2004–2013] and Mazda 6 [2004–2009].
• M49 x 2.5 threads



#F1248
Camshaft Timing Set

Camshaft Holding Fixtures and Chain tensioner hold down tool for Mazda CX-9 [2007-2015].
COMPARABLE: #303-1248 AND #303-1530.



**#OFFM2012
Engine Oil Funnel**



Used on newer Mazda 4 cylinder engines and attaches directly to engine oil filler neck or valve cover. Applicable to Mazda 3 [2006-2018], 5 [2005-2015], CX-5 [2013-2018], CX-9 [2016-2018], Mazdaspeed 3 [2007-2015], Mazdaspeed 6 [2005] and MX-5 Miata [2006-2018].

- **DO NOT USE BRAKE CLEAN**
- **Made of durable ABS plastic**
- **May not fit some applications where the fire wall cowl doesn't provide clearance for attachment of funnel.**

California Residents: Proposition 65
WARNING. See page 125 for info.



**#OFGMRD08
Engine Oil Funnel**



Attaches directly to the oil filler neck. Applicable to Mazda CX-9 [2007-2015].

- **DO NOT USE BRAKE CLEAN**
- **Made of strong polycarbonate**

California Residents: Proposition 65
WARNING. See page 125 for info.



**#OFHON1033
Engine Oil Funnel**



Threads and seals just like the cap. Used on Mazda 2 [2011-2014].

- **DO NOT USE BRAKE CLEAN**

California Residents: Proposition 65
WARNING. See page 125 for info.



**#MO219
Oil Filter Wrench**



Applicable to Mazda 3 [2004-2009], 5 [2006-2011], 6 [2003-2009] and CX-7 [2007-2009].

- **74mm - 14 Flats**
- **Uses 22mm Socket**

California Residents: Proposition 65
WARNING. See page 125 for info.



**#JAS6514
Oil Filter Wrench**

Applicable to Mazda 3 [2012-2018], 6 [2014-2018], CX-3 [2016-2018], CX-5 [2013-2018] and MX-5 Miata [2016-2018].

- **65mm - 14 Flats**
- **3/8" Drive**



**#V450
Brake Caliper
Piston Adapter**



Used for turning in the rear brake caliper piston on Mazda 3.

- **3/8" Drive**



#N512
Flywheel Socket



Flywheel bolt socket used on Nissan models.

- E12
- 1/2" Drive
- 37mm Length

#MSP1412
Magnetic Spark Plug Socket



Used to remove spark plugs on Nissan 1.8L engines and Pathfinder [2015].

- 14mm - 12 Point
- 3/8" Drive
- Strong internal magnet holds spark plug firmly

NOTE: SPARK PLUG SOCKET IS SLENDER IN DESIGN TO FIT APPLICATION



#SP1412
Spark Plug Socket



Used to remove spark plugs on Nissan 1.8L engines and Pathfinder [2015].

- 14mm - 12 Point
- 3/8" Drive
- Rubber boot to hold spark plug

NOTE: SPARK PLUG SOCKET IS SLENDER IN DESIGN TO FIT APPLICATION.



#FZ32A
Tank Adapter



For pressurizing cooling system. Applicable to Nissan Armada [2005–2016] and Titan [2004–2016].

- M52 x 2.5 threads

#8026
Fuel Line Disconnect Tool

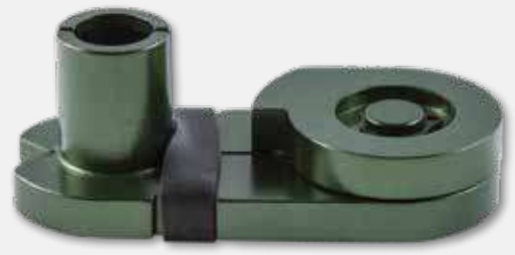

5/16" Fuel Line Disconnect tool for disconnecting the fuel line from the fuel rail on Nissan Altima [2004-2010], Frontier [2005], Murano [2014] and Sentra [2015].

COMPARABLE: #J45488

#FZ36
Cap Adapter



For testing pressure relief valve in cooling system cap. Applicable to Nissan Armada [2005– 2015] and Titan [2004–2015].

- M52 x 2.5 threads



#OFHON1033
Engine Oil Funnel



Fits various Nissan models. Threads and seals just like the cap. Applicable to Nissan Altima [2016-2018], Maxima [2008-2018], Pathfinder [2010-2018], Rouge [2012-2018] and Sentra [2013-2018].

- DO NOT USE BRAKE CLEAN

California Residents: Proposition 65 WARNING. See page 125 for info.



#JAS6514
Oil Filter Wrench

Applicable to Infiniti most models [2004-2018]; Nissan 350Z [2002-2009], 370Z [2010-2018], Altima [1997-2018], Armada [2004-2018], Cube [2009-2014], Frontier [1997-2018], GT-R [2008-2018], Juke [2011-2016], Maxima [1994-2018], Murano [2002-2018], Pathfinder [1995-2018], Quest [2006-2016], Rogue [2008-2018], Sentra [2001-2018], Titan [2003-2018], Versa [2006-2018] and Xterra [2002-2015].

- 65mm - 14 Flats
- 3/8" Drive



#ATFBASIC
Basic Driveline Filler

Used for filling fluids in transmission, differentials and transfer cases (not suitable for use with fuels or solvents). Individual manufacturer sets are available as well as the individual adapters. U.S. made container, made of UHDP (ultra high density polyethylene). Newly designed drum features a second port for filling or dumping fluids without having to remove the pump-sparing both time and clean up afterwards. Used to fill Nissan Leaf gear reduction assembly.

- Used only to Fill, Not to Drain—So Clean Fluid Stays Clean
- 8 Liter Capacity
- Quick Attachment Adapters
- Pump Dispenses Efficiently
- On/Off Ball Valve
- Hose Length: 4ft 10in



ATF CONTAINER IS MADE IN USA

#ATF180
Transmission Filling Adapter



For use with our ATF Driveline Filler Sets. Applicable to Infiniti models with 7-speed automatic transmissions. Applicable to Infiniti EX35 [2008-2012], EX37 [2013-2013], FX35 [2010-2012], FX37 [2013-2013], FX50 [2013-2013], G25 [2011-2012], G37 [2010-2013], G37X [2010-2013], M35H [2012-2013], M37 [2011-2013], M37X [2011-2013], M56 [2011-2013], M56X [2011-2013], Q50 [2014-2014], Q60 [2014-2017], Q70 [2014-2017], QX50 [2014-2017], QX56 [2011-2013], QX60 [2014-2014], QX70 [2014-2017], QX80 [2014-2017]; Nissan Armada [2017-2017], NV1500 [2017-2017], NV2500 HD [2017-2017], NV3500 HD [2017-2017] and Titan [2017-2017].

- M8 x 1.0 Threads

COMPARABLE: #310811EA5A



#ATF125NIS
Transmission Filling Adapter



Used with #ATFBASIC or any of our other ATF filling set to fill the new Nissan CV transmission. Applicable to Infiniti QX60 [2014-2017]; Nissan Altima [2014-2017], Murano [2015-2017], NV200 [2015-2017], Pathfinder [2013-2017], Quest [2015-2017], Rouge [2014-2017], Sentra [2013-2017] and Versa [2013-2017].

- M12 x 1.25 Threads

COMPARABLE: #KV31103950





#TOY300
Toyota Oil Filter Wrench Set

Includes: #TOY640, #TOY730, and #M0219.
With the #TOY300 you have every gas engine Toyota and Lexus model covered [1980–2019].

 California Residents: Proposition 65
WARNING. See page 125 for info.

#M0219
Oil Filter Wrench



Applicable to Toyota 4Runner [1985–2002], Avalon [1995–2002], Camry V6 [1988–2004], Highlander V6 [2001–2010], Previa [1991–1997], Sienna [1998–2007], Solara V6 [1999–2009], Supra [1979–1998], T100 [1993–1998], Tacoma [1995–2012] and Tundra [2000–2004].



- 74mm - 14 Flats
- Used with 22mm socket

 California Residents: Proposition 65
WARNING. See page 125 for info.

#8026
Fuel Line Disconnect Tool

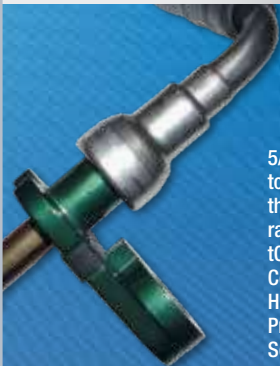

5/16" Fuel line disconnect tool. For disconnecting the fuel line from the fuel rail. Applicable to Scion tC, xA, xB; Toyota Camry, Celica, Corolla, Echo, Highlander, Matrix, MR2, Prius, RAV4, Sequoia, Solara, and Tundra.

COMPARABLE:
#09268-21011



#TOY647LG
Oil Filter Wrench

NEW!

Applicable to Toyota V6 and V8 engines with canister style filter cartridge [2005–2019]. Does not fit on Sequoia.

- 64mm - 14 Flats
- 3/8" Drive



#TOY730
Oil Filter Wrench

Applicable to Lexus ES 250 [1990–1991], ES 300 [1992–2003], ES 300h [2013], ES 330 [2004–2006], GS 300 [1993–2005], GS 400 [1998–2000], GS 430 [2001–2004], GX 470 [2004–2009], IS 300 [2001–2005], LS 400 [1990–2000], LS 430 [2001–2006], LX 450 [1996–1997], LX 470 [1998–2007], RX 300 [1999–2003], RX 330 [2004–2006], RX 400h [2006–2008], SC 300 [1992–2000], SC 400 [1992–2000], SC 430 [2002–2010]; Toyota 4Runner [2003–2009], FJ Cruiser [2007–2009], Land Cruiser [1993–2007], Sequoia [2001–2009], Tacoma [2005–2013] and Tundra [2000–2010].

- 73mm - 14 Flats
- 3/8" Drive - 24mm or 15/16" Socket

 California Residents: Proposition 65
WARNING. See page 125 for info.



#TOY640
Oil Filter Wrench



Applicable to all models with paper cartridge-style filter in Lexus CT 200h [2011–2016], ES 350 [2007–2018], GS 300 [2006–2018], GS 350 [2007–2018], GS 450h [2007–2018], GS 460 [2008–2011], GX 460 [2010–2018], HS 250h [2010–2013], IS 250 [2006–2010], IS 250 C [2010–2016], IS 350 [2006–2018], IS 350 C [2010–2016], IS F [2008–2014], LS 460 [2007–2016], LS 600h [2008–2016], LX 570 [2008–2018], RX 350 [2007–2018], RX 450h [2010–2018]; Scion tC [2005–2016], xA [2004–2006], xB [2004–2016], xD [2008–2013]; Toyota 4Runner [1985–2019], Avalon [1995–2019], Camry [1983–2019], Corolla [1983–2019], Echo [2000–2005], FJ Cruiser [2010–2014], Highlander [2001–2019], Prius [2001–2019], Matrix [2003–2014], MR2 [1985–2005], Paseo [1992–1997], RAV4 [1996–2019], Sequoia [2009–2016], Sienna [2007–2019], Solara [1999–2009], Tundra [2007–2019], Venza [2009–2016] and Yaris [2006–2019].

- 64mm - 14 Flats
- Used with 24mm or 15/16" Socket

 California Residents: Proposition 65
WARNING. See page 125 for info.



#TOY18B
Brake Bleeder Adapter for Toyota

Fits quickly onto brake master cylinder reservoirs on most Toyota vehicles. Used in conjunction with pressure bleeder and 1/4-18 NPT fitting (NOT INCLUDED) to flush brake fluid on a wide range of vehicles. The tool's design reduces time and effort when flushing the brake system. Applicable to most Lexus, Scion and Toyota models.





#TM1215

Ball Joint Hammer Nut

NEW!

Used for breaking free steering knuckle/suspension joints using an impact hammer. Nut must be threaded all the way onto knuckle/suspension joints threaded shafts. Can also be used to remove wheel studs.

- M12 x 1.5 Threads
- 22mm - 7/8" Hex



NOTE: FOR THE COMPLETE 4PC. SET, PURCHASE THE #TM20194 CONTAINING M12X1.25, M12X1.5, M14X1.5 AND M16X1.5.

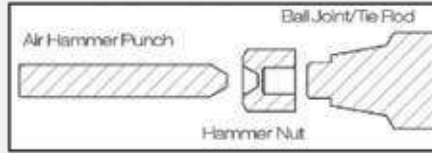

#TM1415

Ball Joint Hammer Nut

NEW!

Used for breaking free steering knuckle/ suspension joints using an impact hammer. Nut must be threaded all the way onto knuckle/ suspension joints threaded shafts.

- M14 x 1.5 Threads
- 22mm - 7/8" Hex



#TOY1914

Serpentine Belt Wrench for Toyota



Equipped with 14mm and 19mm, 12 point secured attachments. Works on most Toyota applications (except Hybrids). Applicable to Scion FR-S [2014]; Toyota Corolla [1998-2005], Highlander [2008], Matrix [2004], RAV4 [2002], Sequoia [2008] and Tundra [2008].



#TOY288

Front Hub Nut Socket



Used for R & R of the front hub lock nut on Toyota 2WD trucks [2007-Newer]. Applicable to Sequoia [2008-2014] and Tundra [2007-2014].

- 3/4" Drive

COMPARABLE: #09602-60010



#OFTOY1038

Engine Oil Funnel



Applicable to All Toyota and Lexus models with a threaded oil cap. For Toyota and Lexus 1/4-turn style oil caps see #OFTOY1001.

- DO NOT USE BRAKE CLEAN

NOTE: FOR TOYOTA PRIUS AND YARIS, THE FUNNEL NEEDS TO BE USED IN CONJUNCTION WITH OUR #OFT38 OR #OFA38 EXTENSION.



California Residents: Proposition 65 WARNING. See page 125 for info.

#OFT38

Funnel Extension for Toyota



Adds coverage and access where normal funnels do not fit. Applicable to Toyota Prius and Yaris. Only used in conjunction with #OFTOY1038 or #OFTOY38 funnels.

- DO NOT USE BRAKE CLEAN

California Residents: Proposition 65 WARNING. See page 125 for info.



#ATFTOY118

ATF Adapter for Toyota



Toyota driveline filler adapter used in conjunction with our ATF Filler Systems (see pages 84-87). Applicable to some Lexus models; Toyota 4Runner [2005-2010], Camry [2007-2017], FJ Cruiser [2007-2010], Sequoia [2005-2010], Tacoma [2005-2010] and Tundra [2005-2010].

- M18 x 1.5 Threads

COMPARABLE: #00002-11103-02

#TOY105

Head Bolt Socket



Used for newer Toyota Yaris, Prius that use a special #8 bi-hexagon socket. Applicable to Toyota Paseo, Prius [2001-2009], Tercel and Yaris [2006-2013].

- #8 BI-HEXAGON
- 1/2" Drive
- 100mm Length

#CVB15
CV Clamp Crimping Tool

Used to crimp on clamps for CV boots on all Toyota with crimp style CV boots. Instead of squeezing pliers together, drive the #CVB15 with your 3/8" drive ratchet to crimp these clamps.



#TOY211
A/C Clamp Remover



NEW!



Used for removing line clamps found on Toyota Tacoma [2015-2018]. Fits both high and low side clamps.

- Manufactured from 304 Stainless Steel
- 5" length
- Appropriate chamfer opens clamps



#7200
Camshaft Pulley Holder

Fits Toyota models. Includes 3 sets of interchangeable pins. Pins may be threaded in two different locations, based on application access. Overall length 18". 12" spread between pins at tip of arms, when pivot arm is at 90 degrees. Holding pins are made in USA.



#100-30A
Axle Nut Socket

Thin-walled Applicable to Toyota models with 30mm 12-point axle nuts.



- 30mm
- 1/2" Drive
- 85mm Length

#TOY200
A/C Clamp Remover



For removing special air condition line clamps. Fits both Toyota A/C clamps, used on high and low pressure lines [1998–newer].

- For Tacoma [2015-2018], see #TOY211.
- Stainless steel release pins.

COMPARABLE: #09870-00015
AND #09870-00025



#S3054X-10
Head Bolt Socket



Used for R & R of cylinder head bolts on Toyota Matrix [2003-2007].

- 10mm
- 1/2" Drive
- 140mm Length



#FZ13818
Coolant Adapter



For pressurizing cooling system. Works with many different Toyota models with small, shallow necks, including Toyota Camry [1992-2019], Highlander [2019], Sienna [2010-2019], Tacoma [2006-2019] and Tundra [2000-2019].



#FZ148
Tank Adapter



For pressurizing cooling system. Applicable to Lexus LS 460 [2007-2013]; Lotus Elise [2005]; Scion tC [2011-2013], xB [2011-2013]; Toyota Celica GTS-S, Highlander [2006-2010], MR2 Spyder, Prius [2001-2016] and RAV4 [2006-2018].

- M34 x 3 Threads



#S3054X-12
Head Bolt Socket



Used for R & R of cylinder head bolts on Toyota 4Runner with V6 [2003], all 2ZZ engines 4 cylinder with VVT including Celica [2000-2001] and Highlander [2001-2006] with 2AZ-FE engines.

- 12mm
- 1/2" Drive
- 140mm Length

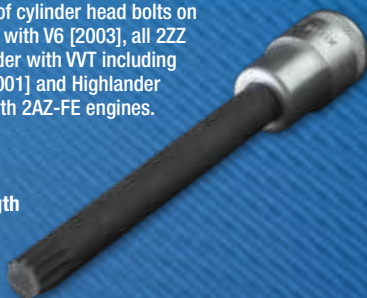

#TOY185
Wheel Bearing Nut Socket



Used for R & R of wheel bearing nut located on inboard side of wheel hub on 2WD Toyota 4Runner [1995-2006], T100 [1995-1998] and Tacoma [1995-2006].

- 1/2" Drive

COMPARABLE: #09318-12010-SOCK



**#SU8252
Crankshaft Socket**

NEW!

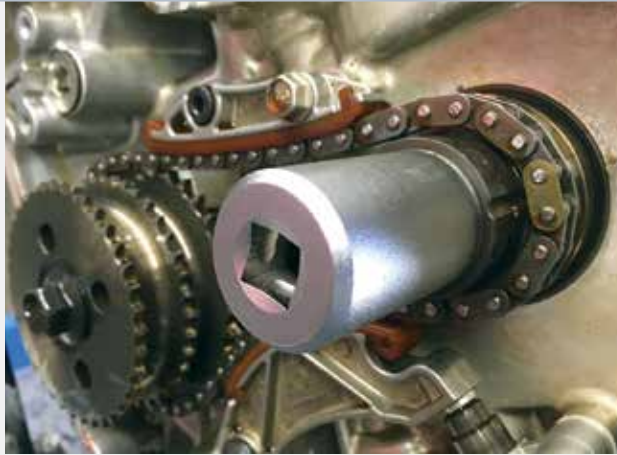

Used to align crank to T.D.C. while working with the timing chain. Also works on older 3.0L 6 cylinder DOHC engines. Applicable to Subaru BRZ [2013-2017], Forester [2012-2017], Impreza [2012-2017], Impreza WRX [2015-2017], Legacy [2013-2015], Outback [2013-2015], Tribeca B9 and Crosstrek [2013-2017].

- 1/2" Drive

COMPARABLE: #18252AA000

**#SU7500
Crankshaft Socket**



Crankshaft Socket for Subaru used to align crank to T.D.C. while working with the timing belt on Subaru Baja [2003-2006], Forester [1998-2013], Impreza [1997-2011], Impreza WRX [2002-2014], Impreza WRX STI [2004-2014], Legacy [1996-2012] and Outback [1996-2012].

- 1/2" Drive

COMPARABLE: #499987500

**#SU3625
Camshaft Sprocket Holder**



Used to hold the camshaft sprockets on 2.5L turbo and 3.6L engines. Applicable to Subaru Baja [2004-2006], Forester [2004-2013], Impreza WRX [2006-2014], Impreza WRX STI [2004-2015], Legacy [2005-2015], Outback [2005-2015] and Tribeca [2006-2014].

NOTE: 2.5L DOHC TURBO ENGINES WILL ALSO REQUIRE THE USE OF THE #SU 200T IN CONJUNCTION WITH #SU 3625.

COMPARABLE:
#499977500



**#SU200T
Camshaft Pulley Holder**

Used to hold the camshaft pulley for removal on 2.0L Turbo, 2.5L Turbo and 2.5L SOHC engines. Applicable to Subaru Baja [2004-2006], Forester [1999-2013], Impreza [1999-2011], Impreza WRX [2002-2014], Impreza WRX STI [2004-2015], Legacy [1999-2012] and Outback [2005-2012].

NOTE: 2.5L DOHC TURBO ENGINES WILL ALSO REQUIRE THE USE OF THE #SU 3625 IN CONJUNCTION WITH #SU 200T.

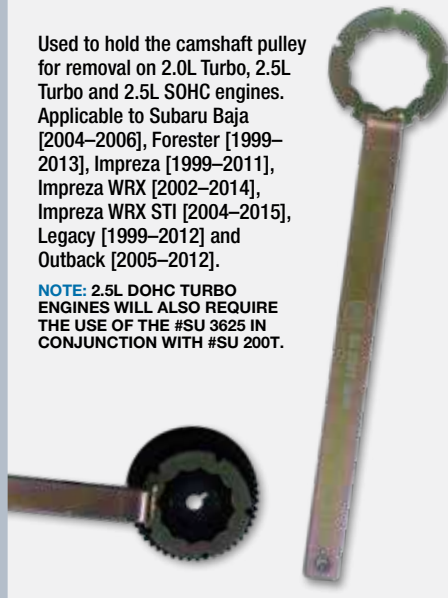

**#SU7250
Cam Pulley Holder**



Used to hold the crankshaft pulley on 2.5L engines. This tool works on models with crank pulley Subaru part #12305AA251 on Baja [2003-2006], Forester [1999-2013], Impreza [1999-2014], Impreza WRX [2002-2014], Legacy [1999-2012] and Outback [2002-2012].

- 1/2" Drive

COMPARABLE: #499977100. IF YOUR CAR IS EQUIPPED WITH PULLEY #12305AA242, PLEASE SEE #SU499977400.

IMPORTANT NOTE: IN SOME CASES, VARIOUS REPAIR MANUALS AND SERVICES CALL FOR THE #499977100, BUT IS NOT THE CORRECT TOOL NEEDED. VERIFY YOUR VIN# WITH A DEALERSHIP TO FIND OUT WHICH PULLEY YOU HAVE FOR SURE.

**#SU250
Camshaft Gear Holder**

Camshaft gear holding tool is only used for holding the pulley while breaking the camshaft gear nut loose Subaru 2.5L DOHC (non-turbo) engines [1996-1999]. Applicable to Subaru Forester [1998], Impreza RS [1998], Legacy [1997-1999] and Outback [1996-1997].

NOTE: THIS IS NOT USED FOR SETTING THE TIMING.

COMPARABLE: #499207300



RATCHET NOT INCLUDED

#OFSU1042
Engine Oil Funnel



Prevents unwanted mess. Threads on and seals to the filler neck, just like the oil cap on all Subaru models through 2019 with threaded oil cap (except Tribeca). Also fits the Subaru BRZ [2013-2018] and Scion FR-S [2013-2016].

- DO NOT USE BRAKE CLEAN

WARNING: California Residents: Proposition 65. See page 125 for info.

#OFSU42
Funnel Adapter



For use only in conjunction with our #FUN14KIT or #OFKIT. Fits all Subaru models with threaded oil cap (except Tribeca). Also fits the Subaru BRZ and Scion FR-S.

- DO NOT USE BRAKE CLEAN
- We left space in the #FUN14KIT to accommodate this adapter.
- Purchase separately

WARNING: California Residents: Proposition 65. See page 125 for info.



#SU6514
Oil Filter Wrench

Used on Subaru factory oil filter #15208AA12A [2000-2018].

- 65mm - 14 Flats
- 3/8" Drive



#GM245
GM Fuel Injector Seal Set



NEW!

Used for replacing the fuel injector seals on Subaru 2.0L Turbo and 2.4L Turbo engines [2014-2019].



#SU8015
Oil Filter Wrench

Applicable to Subaru BRZ [2013-2017], Forester [2016+], Impreza WRX [2016+], Legacy (6-cyl.), Outback and Tribeca.

- 80mm - 15 Flats
- 3/8" Drive

FITS NAPA GOLD OIL FILTER #1334



#TM12125
Ball Joint Hammer Nut

NEW!

Used for breaking free steering knuckle/suspension joints using an impact hammer. Nut must be threaded all the way onto knuckle/suspension joints threaded shafts. Can also be used to remove wheel studs.

- M12 x 1.25 Threads
- 22mm - 7/8" Hex

NOTE: FOR THE COMPLETE 4PC. SET, PURCHASE THE #TM20194 CONTAINING M12X1.25, M12X1.5, M14X1.5 AND M16X1.5.

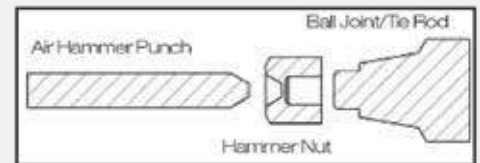

#FZ13818
Tank Adapter



For pressurizing cooling system in Subaru vehicles with small, shallow necks. Applicable to Subaru Ascent [2019], BRZ [2013-2017], Forester [2016], Impreza [2006-2018], Legacy [2016], Outback [2005-2018], Tribeca B9 [2006] and Crosstrek [2013-2018].



**#MSP1412
Magnetic Spark Plug Socket**



Applicable to Subaru BRZ [2013-2018] and Forester [2013-2018].

- 14mm - 12 Point
- 3/8" Drive
- Strong internal magnet holds sparkplug firmly

NOTE: SPARK PLUG SOCKET IS SLENDER IN DESIGN TO FIT APPLICATION.



**#SP1412
Spark Plug Socket**



Applicable to Subaru BRZ [2013-2018] and Forester [2013-2018].

- 14mm - 12 Point
- 3/8" Drive
- Rubber boot to hold spark plug

NOTE: SPARK PLUG SOCKET IS SLENDER IN DESIGN TO FIT APPLICATION.



**#ATFSU100
Universal ATF Attachment**



Used with our ATF driveline fillers. This flexible adapter is used to fit into hard to reach applications where there is at least a 10mm internal diameter opening to fit into. Applicable to newer Subaru automatic turbo models where the intercooler is blocking access to transmission fill tube.

RECOMMENDATION: USE WITH #ATFBASIC.



**#8028
Fuel Line Disconnect Tool**

Applicable to Subaru Forester [2004-2014], Impreza [2004-2011], Impreza WRX [2004-2014], Impreza WRX STI [2004-2014] (except 2006), Legacy [2004-2014], Outback [2004-2014] and Tribeca [2004-2014].

COMPARABLE:
#18371AA000
AND #42099AE00



**#SU070
Drain Plug Socket**



Used for R & R of the drain plug on Manual Transmission. Applicable to Subaru with manual transmission [2003- 2016].

- T-70
- 1/2" Drive
- 105mm Length

**#ATFSU118
Filling Adapter**

NEW!

Used for filling the front Differential. Applicable to Subaru Cross Trax [2012-2017], Forester (non turbo) [2014-2017], Impreza (non turbo) [2012-2017], Legacy (4 cyl.) [2013-2017] and Outback (4 cyl.) [2013-2017]. Used in conjunction with our ATF BASIC and our other ATF Filling Sets.

- M18 x 1.5 Threads

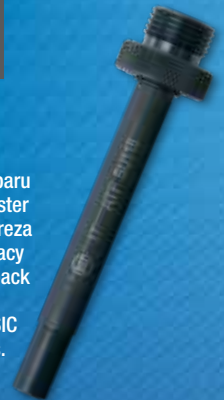



TOOLS FOR **DOMESTIC MODELS 21-32**

CHRYSLER / DODGE / JEEP / RAM	22-24
FORD	25-30
GENERAL MOTORS	31-32
TESLA	107





#8016
1/2" Oil Cooler Line Remover

For removing both oil cooler lines from fitting on automatic transmission and oil coolers. Applicable: Dodge Ram trucks with V10 or Cummins turbo diesel [1995–2016].



#2124
Oil Filter Socket

Applicable to Chrysler 200 [2011–2016], 300 [2011–2013], Town & Country [2011–2016]; Dodge Avenger, Challenger, Charger, Durango, Grand Caravan and Journey [2011–2016].

- 24mm - 6 Flats
- 3/8" Drive



#2127
Oil Filter Socket

Applicable to Dodge Dart [2012–2013].

- 27mm - 6 Flats
- 3/8" Drive



#2175
Oil Filter Socket



Applicable to Dodge Sprinter 2.7L [2003–2006].

- 74.5mm - 14 Flats
- Used with 22mm socket



California Residents: Proposition 65
WARNING. See page 125 for info.

#M0284
Oil Filter Wrench



Used on 3.0L CRD (Common Rail Diesel) V6 engines in Dodge Sprinter [2007–2013] and Jeep Grand Cherokee [2007–2008].

- 84mm - 14 Flats
- Used with 22mm socket



California Residents: Proposition 65
WARNING. See page 125 for info.

#M0219
Oil Filter Wrench



Used on Dodge Avenger [2012–2013], Caliber [2012–2013], Dart [2012–2013] & Sprinter (gas) [2003–2012].

- 74mm - 14 Flats
- Used with 22mm socket



California Residents: Proposition 65
WARNING. See page 125 for info.

#TOY640
Oil Filter Wrench



Used to remove and install the transmission cooling return line filter on 45RFE and 545RFE automatic transmissions found in Chrysler, Dodge and Jeep vehicles.

- 64mm - 14 Flats
- Used with 22mm socket



California Residents: Proposition 65
WARNING. See page 125 for info.



#OFCRY36
Engine Oil Funnel



Used for Chrysler and Dodge models equipped with the 3.6L engine. Applicable to Chrysler Town & Country; Dodge Avenger, Challenger, Charger, Dart, Durango, Grand Caravan, Journey and Jeep Wrangler [2011–2017].

- DO NOT USE BRAKE CLEAN
- Made of strong polycarbonate
- Creates a custom fit to valve covers and filler necks

California Residents: Proposition 65
WARNING. See page 125 for info.



#FUNCRY36
Funnel Adapter



Oil funnel adapter for Chrysler/Dodge models equipped with the 3.6L engine. This is to be used with our #FUN14KIT. Applicable to Chrysler Town & Country; Dodge Avenger, Challenger, Charger, Dart, Durango, Grand Caravan, Journey and Jeep Wrangler [2011–2017].

- DO NOT USE BRAKE CLEAN
- Made of strong polycarbonate
- Creates a custom fit to valve covers and filler necks

California Residents: Proposition 65
WARNING. See page 125 for info.



#OFHON1033
Engine Oil Funnel



Engine oil Funnel. Threads and seals just like the cap.
Applicable: Dodge Caravan 3.8L, Challenger, Charger and RAM Trucks equipped with 5.7L Hemi engines [2010-2018] and Jeep Wrangler [2002-2011].

- DO NOT USE BRAKE CLEAN

 California Residents: Proposition 65
WARNING. See page 125 for info.



#FZ55
Tank Adapter



Cooling system pressure tester adapter. Applicable to Dodge / Freightliner / Mercedes Sprinter vans [2007-2019].

- M46 x 2.5 Threads



#FZ25
Tank Adapter



For pressurizing cooling systems of Ram Trucks Promaster Van [2014-2018].

- M47 x 3 Threads

#FZ35A
Tank Adapter



For pressurizing cooling system. Works with many different domestic vehicles. Applicable to Chrysler 200 [2015], Pacifica [2017]; Jeep Grand Cherokee [2016-2017] and RAM 3.6L, 3.0L EcoDiesel [2014-2018] and 6.7L Cummins [2013-2018].

- M52 x 2.5 Threads

NOTE: DOES NOT FIT HEMI



#SPR0558
Glow Plug Pliers

For disconnecting the electrical connector that is attached to the glow plug used on Dodge Sprinters.

COMPARABLE: #9286



#M1020
Glow Plug Socket

Applicable to Dodge Sprinter.

- 10mm
- 3/8" Drive



#M820
Glow Plug Socket

Applicable to Dodge Sprinter.

- 8mm
- 3/8" Drive





#7200
Camshaft Pulley Holder

Fits multiple Chevrolet, Dodge, Ford and GMC models. Includes 3 sets of interchangeable pins. Pins may be threaded in two different locations, based on application access. Overall length 18". 12" spread between pins at tip of arms, when pivot arm is at 90 degrees. Holding pins are made in USA.

FOR DODGE OR GM COVERAGE, YOU WILL ALSO NEED TO PURCHASE TWO #7200-4 PINS



#7200-4
Pins



For use with #7200 camshaft pulley holder. Holds camshaft gears on Dodge Durango 4.7L [2000-2009].

- Must purchase '2' (two) to make a pair.

NOTE: AVAILABLE SEPARATELY, NOT INCLUDED IN #7200



#SPR886
Transmission Dipstick

Used on Dodge / Freightliner Sprinter [2002-2009] and Chrysler Crossfire [2004-2008].

COMPARABLE: #8863B



#CRY323
Transmission Dipstick



Stainless steel design and clear level marks with a knurled handle. Applicable to all 6F24 6-speed and 948TE 6-speed automatic transmissions found in Dodge Dart [2012-2016], Fiat 500 [2012-2017]; Jeep Cherokee [2014-2017], Compass [2014], Patriot [2014] and Renegade [2015-2017].

COMPARABLE: #10323A



#CRY933
Transmission Dipstick

Used on all vehicles equipped with a NAG1, 42RLE, 62TE and CVT transmission. Applicable to Chrysler 200 [2011-2014], 300 [2006-2014], Aspen [2008-2009], Pacifica [2007-2008] Sebring [2007-2013], Town & Country [2008-2017]; Dodge Avenger [2007-2014], Caliber [2007-2012], Challenger [2008-2014], Charger [2006-2014], Dakota [2008-2011], Durango [2008-2013], Grand Caravan [2008-2017], Journey [2009-2014], Magnum [2006-2013], Nitro [2007-2011], Promaster [2014-2017], Ram [2007-2013], Jeep Commander [2006-2010], Grand Cherokee [2006-2013], Liberty [2006-2012], Patriot [2007-2013] and Volkswagen Routan [2009-2014].

COMPARABLE: #9336 AND #9336A





**#ATF101
ATF Adapter**



Adapter used in conjunction with the ATF Filler System for Ford Explorer [2004–2010], Mustang [2005–2010] and Thunderbird [2002–2005].

- 1/8-27 NPT Threads
- Does not include pump, container, hose, or shut-off valve.
- **NOTE:** FOR THE COMPLETE FORD SET, SEE TOOL #ATF FORD

**#FZ32A
Tank Adapter**



For pressurizing cooling system. Applicable to Ford Edge 3.5L [2013], Escape [2010-2012], Excursion [2002-2004], Explorer [2014-2016], F150 [2004-2014], F250 [2002-2016], Five Hundred [2005], Fusion [2010-2012], Mustang [2011-2014] and Taurus [1996-2006].



- M52 x 2.5 Threads

**#FZ35A
Tank Adapter**



For pressurizing cooling system. Offers the same Ford coverage as the #FZ32A.



- M52 x 2.5 Threads

**#FZ36
Cap Adapter**



Used to test coolant pressure cap. Works with many domestic vehicles.



- M52 x 2.5 Threads

**#FZ47
Tank Adapter**



For pressurizing the cooling system. Applicable to Ford C-Max [2014-2016], EcoSport [2018], Edge [2013–2018], Escape [2014–2018], Expedition [2015–2018], F-150 [2015–2018], Fiesta [2011–2018], Focus [2012–2018], Fusion [2013–2018], Mustang [2016–2018], Transit 150/250 [2015–2016] and Transit Connect [2014–2015].

- M49 x 2.5 Threads



**#ATFFORD
Driveline Filler**

ATF CONTAINER IS
MADE IN USA



Used for filling Ford Explorer [2004–2010], Mustang [2005–2010] and Thunderbird [2002–2005] automatic transmissions.

- 8 Liter capacity
- Hose length: 4' 10"
- #ATF101 adapter included.
- U.S. made container, made of UHDP (ultra high density polyethylene).

**#F1616T
Engine Timing Set**



NEW!

Used to set timing on the 1.6L Naturally Aspirated and 1.5L/1.6L EcoBoost Turbocharged engines on Ford Escape [2013-2018], Fiesta [2011-2018], Fusion [2013-2018] and Transit Connect [2014-2017].

COMPARABLE: #303-748, #303-1097 AND #303-1550.



**#F1616-1552
Camshaft Alignment Tool**

NEW!

Used to align the rear camshafts on 1.6L EcoBoost engines when the VCT (Variable Camshaft Timing) Phasers have been removed from the front of the camshafts on Ford Escape [2013-2015], Fiesta [2014-2016], Fusion [2013-2014] and Transit Connect [2014-2016].

COMPARABLE: #303-1552



**#F1616-376B
Camshaft Alignment Tool**

NEW!

Used to align the rear camshafts on 1.6L (non-turbo) engines when the VCT (Variable Camshaft Timing) Phasers have been removed from the front of the camshafts. Applicable to Ford Fiesta [2013-2017].

COMPARABLE: #303-376B



**#F16393
Flywheel Lock**

NEW!

Used to hold the flywheel on 1.5L / 1.6L Ford engines. Applicable to Ford Escape [2013-2018], Fiesta [2011-2018], Fusion [2013-2018] and Transit Connect [2014-2017].

COMPARABLE:
#303-393A
PLATE AND
#303-393-02



#F20T
Engine Timing Set

For Ford models with 2.0L turbo EcoBoost engine. Includes the T.D.C. crank timing pin, cam locking plate and the crank position sensor (CPS) alignment block. Applicable: Ford Edge [2013–2015], Escape [2013–2015], Explorer [2012–2015], Focus [2012–2015], Fusion [2013–2015] and Taurus [2013–2015].

COMPARABLE: #303-507, #303-1521, AND #303-1565



#FM2330
3-Piece Timing Set

Used on all Ford 2.0L, 2.3L (turbo and naturally aspirated) and 2.5L engines. *[2004-older] 2.0L engines use the FM 2303 crank pin. Applicable to Ford Escape [2005–2013], Focus [2005–2013], Fusion 2006–2013 and Ranger [2001–2011].

COMPARABLE: #303-507, #303-465 AND #303-1061.



#FM2303
Crank Locking Pin



Used in conjunction with #FM2330 Ford and Mazda timing set. Applicable to Ford Contour [1998–2000], Escape [2001–2004], Escort ZX2 [1998–2003], Focus [2000–2004]; Mercury Cougar [1999–2002] and Mystique [1998–2000].

COMPARABLE: #303-574

#F1248
Camshaft Timing Set

Camshaft Holding Fixtures and Chain tensioner hold down tool for Ford/Lincoln models with 3.5L, 3.5L Eco-boost and 3.7L in Ford Edge [2007–2015], Explorer [2011–2015], F-150 [2011–2015], Flex [2009–2015], Fusion [2010–2012], Mustang [2011–2015], Police Interceptor [2014–2015], Taurus [2008–2015]; Lincoln MKS [2009–2015], MKT [2010–2015], MKX [2007–2015], MKZ [2007–2015] and Navigator [2015].

COMPARABLE: #303-1248 AND #303-1530.



#1018
10pc. Line Disconnect Set

NEW!

For R&R of transmission oil cooler lines, fuel filters and fuel lines. This new set includes GM Duramax injector line tool and Subaru fuel line disconnect tool.



#8010
1/4" Fuel Line Remover



For the removal of 1/4" return lines on the fuel pump on Ford Mustang [1995–1996].

#8021
3/8" Oil Cooler Line Remover

For disconnecting transmission oil cooler lines. Flares on the cooler lines near the fittings prevent access with original style tools. The locking clip used in the fitting is different than the standard 'tabs' used on most other applications. #8021 clears the flare and disconnects the new style clips with ease. Applicable: Ford Explorer [2003–2004], F-150 [2003–2008], Expedition [2005] and Cadillac CTS [2003–2004].



#8012
5/16" Fuel Filter Remover



Made of red-anodized aluminum. For R & R of the fuel filter and 5/16" return line from the fuel pump-sending unit. Applicable: Ford Areostar [1990–2006], Bronco, Explorer, E-Series vans [1991–2006], F Series trucks and Ranger [1992–2006].

#8024
1/2" Oil Cooler Line Remover

For R & R of transmission oil cooler lines on Ford Explorer [2007], Sport Trac, Ranger, various other Ford models.



#8013
3/8" Fuel Line Remover



For removing 3/8" fuel lines and feed lines from the fuel pump-sending unit on Ford Areostar [1990–2006], Bronco, Explorer, E Series vans [1991–2006], F-Series trucks and Ranger [1992–2006].

#8023
1/2" Oil Cooler Line Remover

Used to disconnect 1/2" transmission oil cooler lines on Ford Escape with 6F transmission [2009], Edge [2012], Excursion/ F -250/ F-350 with 6.0L turbo diesel [2005] and Explorer V8 [2008].



#8014
5/16" Special Line Remover

For removing both oil cooler lines from the fittings on automatic transmissions on Ford Taurus/Escorts with the AXOD and ATX transmissions.



#OFGMRD08
Engine Oil Funnel



Attaches directly to the oil filler neck on E-Series Van, Edge, Escape [2011], Expedition, Explorer, F-150 [2013-2016], F-250 6.7L Powerstroke [2016-2018], Flex, Mustang [2005-2016], Ranger, Taurus [2011] and Transit [2016].

- DO NOT USE BRAKE CLEAN
- Made of strong polycarbonate

NOTE: FOR FORD POWER STROKE DIESEL ENGINES (6.9L, 7.3L, 6.0L AND 6.4L), SEE #OFHON1033



 California Residents: Proposition 65
WARNING. See page 125 for info.

#OFFM2012
Engine Oil Funnel



Used on newer Ford 4 cylinder engines and Attaches directly to engine oil filler neck or valve cover.

Applicable to Ford EcoSport [2018], Edge [2012-2018], Escape [2008-2016], Expedition [2016-2018], Explorer [2012-2016], F-150 [2016-2018], Focus [2007-2018], Fusion [2013-2018] and Mustang [2018].

- DO NOT USE BRAKE CLEAN
- Made of durable ABS plastic
- May not fit some applications where the fire wall cowl doesn't provide clearance for attachment of funnel.

 California Residents: Proposition 65
WARNING. See page 125 for info.



#OFHON1033
Engine Oil Funnel



Threads and seals just like the cap. Used on Ford F-150, F-250 and F-350 6.0L (turbo diesel), also fits Ford power stroke engines (6.9L, 7.3L, 6.0L and 6.4L).

- DO NOT USE BRAKE CLEAN

 California Residents: Proposition 65
WARNING. See page 125 for info.



#OFAAGM
Angled Funnel Extension



Oil Funnel Extension for our #OFGMRD08 Oil Funnel. Adds coverage and access where normal funnels do not fit. Applicable to Ford F-150 and F-250 [2015-2016].

- DO NOT USE BRAKE CLEAN
- Made of durable ABS plastic

 California Residents: Proposition 65
WARNING. See page 125 for info.



#MSP1412
Magnetic Spark Plug Socket



Used to remove spark plugs on Ford 4.6L and 5.4L engines.

- 14mm - 12 Point
- 3/8" Drive
- Strong internal magnet holds spark plug firmly.

NOTE: SPARK PLUG SOCKET IS SLENDER IN DESIGN TO FIT APPLICATION.



#SP1412
Spark Plug Socket



Used to remove spark plugs on Ford 4.6L and 5.4L engines.

- 14mm - 12 Point
- 3/8" Drive
- Rubber boot to hold spark plug

NOTE: SPARK PLUG SOCKET IS SLENDER IN DESIGN TO FIT APPLICATION.



#2127
Oil Filter Socket



Applicable to Ford F-150 2.7L EcoBoost [2015-2016].

- 27mm - 6 Flats
- 3/8" Drive

#2136
Oil Filter Socket



Applicable to Ford F-250 and F-350 6.0L turbo diesel [2004].

- 36mm - 6 Flats
- 3/8" Drive

#V450
Brake Caliper Piston Adapter

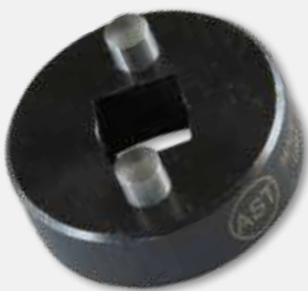

Used for turning in the rear brake caliper piston on Ford Fusion and Lincoln MKZ.

- 3/8" Drive

#BFLT60
Wheel Bearing Torx Socket



This special machined, long T60 Torx socket is machined for clearance to access the rear wheel bearing bolts without hitting the ABS rotor sensor on Ford Edge / Lincoln MKX [2007-2013].

- 1/2" Drive
- 140mm Length

#M0219
Oil Filter Wrench



Applicable to Ford Escape [2006-2008], Focus [2004-2007] and Fusion [2006-2008].

- 74mm - 14 Flats
- Used with 22mm socket

#OFAAGM
Angled Funnel
Extension



Oil Funnel Extension for our #OFGMRD08 Oil Funnel. Adds coverage and access where normal funnels do not fit. Fits Chevy Silverado (gas) and GMC Sierra (Gas) [2013–2014].

- DO NOT USE BRAKE CLEAN
- Made of durable ABS plastic

NOTE: ONLY USED IN CONJUNCTION WITH #OFGMRD08 OR #OFGMFORD FUNNEL.

 California Residents: Proposition 65
WARNING. See page 125 for info.



#GM140
Engine Timing Set

NEW!

Used to set the Timing on GM 1.4L Ecotec in Buick Encore [2013-2018]; Chevy Cruze [2011-2018], Sonic [2011-2018] and Trax [2013-2018].

- Comes in plastic storage case



#GM245
GM Fuel Injector
Seal Set



NEW!



Used for replacing the fuel injector Teflon seals on 2.0L & 3.6L engines with Hitachi fuel injectors [2010-2017] and 2.0L, 2.5L, 5.3L & 6.2L engines with Bosch, Continental and Delphi fuel injectors [2012-2017].

COMPARABLE: #EN-49245 AND #EN-51105



#OFGMRD08
Engine Oil Funnel



Attaches directly to the oil filler neck. Applicable to Cadillac, Chevrolet and GMC vehicles.

- DO NOT USE BRAKE CLEAN
- Made of strong polycarbonate

 California Residents: Proposition 65
WARNING. See page 125 for info.



#2124
Oil Filter
Socket

Applicable to Chevrolet Trax [2015].

- 24mm - 6 Flats
- 3/8" Drive





#8021
3/8" Oil Cooler Line Remover



For disconnecting transmission oil cooler lines. Flares on the cooler lines near the fittings prevent access with original style tools. The locking clip used in the fitting is different than the standard 'tabs' used on most other applications. #8021 clears the flare and disconnects the new style clips with ease. Applicable to Cadillac CTS [2003–2004] and Chevrolet Corvette [1997–2004].



#8022
Fuel Filter Removal Tool for GM

For the R & R of the fuel filter on Chevy Suburban and Tahoes [2002–2004].



#8027
3/16" Fuel Line Release Tool

Used for R & R of fuel lines. Made of orange anodized aluminum. Applicable to Express Van, Sierra and Silverado with 6.6L V8 Duramax engine [2011–2016].



#7200-4
Pins



Must purchase '2' (two) to make a pair. For use with #7200 camshaft pulley holder. Used to hold GM water pump pulley on 4.2L straight-6 Vortec engine.

NOTE: AVAILABLE SEPARATELY, NOT INCLUDED IN #7200

#ATF175GM
Transmission Filling Adapter



Used on GM vehicles equipped with 6L80/6L90 6-speed automatic transmission. Used in conjunction with our ATF Driveline Filler Sets. Applicable to Cadillac CTS-V [2009], Escalade [2009], STS, XLR-V [2006]; Chevrolet Camaro [2010], Caprice [2011], Corvette [2006], Silverado 1500 [2009]; GMC Yukon Denali [2007]; Pontiac G8 [2008].

• M12 x 1.75 Threads

NOTE: FOR USE WITH #ATF BASIC

#FZ13818
Radiator Adapter



For pressurizing cooling system. Application to vehicles with small, shallow necks. Used on Chevrolet Metro, Prizm and Tracker [1998].

#FZ36
Cap Adapter



Used to test coolant pressure cap. Applicable to GM models with threaded coolant caps [1999–2018].

• M52 x 2.5 right hand threads

#FZ35A
Tank Adapter



For pressurizing cooling system. Applicable to GM models [1999–2018]. (Except Duramax [2017–2018], hybrid and electric vehicles require a different tank adapter.)

• M52 x 2.5 right hand threads





TOOLS FOR **EUROPEAN MODELS 33-72**

BMW / MINI 34-46

JAGUAR / LAND ROVER 47-49

MERCEDES 50-54

VOLVO 55-56

VW / AUDI / PORSCHE 57-72



#BMW0062
A/C Stretch Belt Tool



Used for installing the stretch belt (no belt tensioner is used) on N62 engines [2004-2010].

COMPARABLE: #641040 & #83800494518

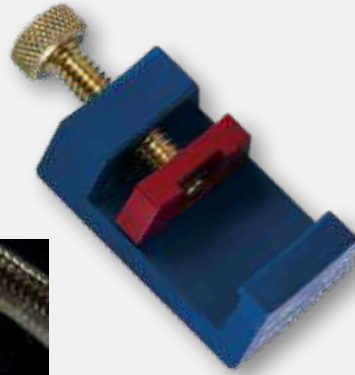

#BMW5346
Line Disconnect Tool



Used for the power steering and transmission oil cooler lines on BMW 3 series and X5 [1999-2011].

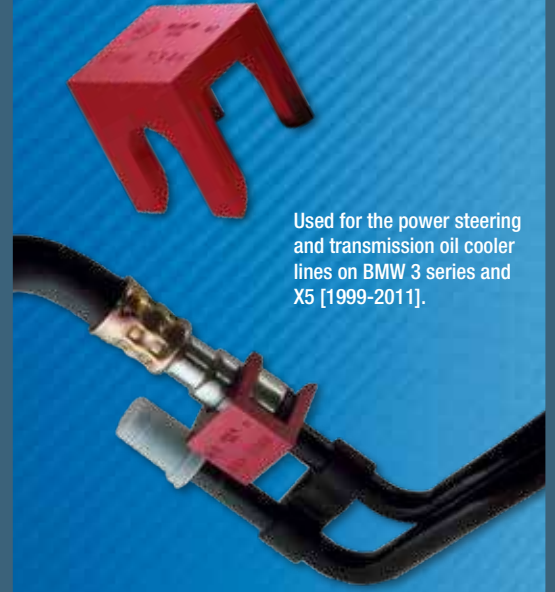

#BMW124052
A/C Stretch Belt Tool



Used for installing the stretch belt (no belt tensioner is used) on BMW X5 3.0L gas engines [2007-2010].

- 1/2" Drive

COMPARABLE: #111240

#BMW124057
A/C Stretch Belt Tool



Used for installing the stretch belt on M57Y diesel engines in 335d & X5 35d [2009-2013].

- 1/2" Drive

COMPARABLE: #110330

#FZ25
Tank Adapter



Applicable to BMW 330e, 530e, 740e & X5 40e [2016-2019], i3 & i8 [2014-2019], BMW V8 (twin turbo) intercooler coolant reservoir [2008-2017] & Mini Cooper Models.

- M47 x 3 threads



#BMW345
Tank Adapter



Used to pressurize most BMW coolant reservoirs [1996-2006]. For 5 & 6 series cars [2004-2005], see #BMW350.

- M51 x 4 threads



#BMW350
Tank Adapter



Used to pressurize BMW coolant reservoirs [2006-2019]. See application chart for model years.

- M52 x 3 threads



#BMW8390
Line Disconnect Tool



Used to disconnect fuel lines on BMW 3 series [2006-2011], X3 [2006-2009] and Mini Cooper N14 engines [2007-2013].

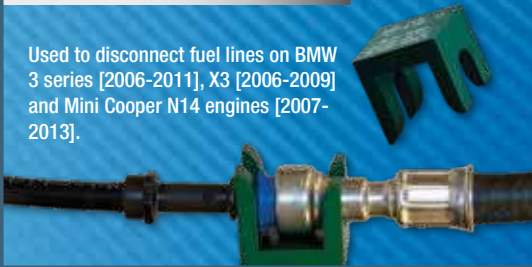

#BMW5532
Fuel Injector Tool

Used to remove and install injectors on N20 and N55 engines.

COMPARABLE: #130320



#8032
Fan Clutch Wrench

Used for R & R of any 32mm fan clutch nuts.



#BMW4622
Fuel Level Sensor Lock Ring Tool



FUEL LEVEL LOCK RING



Used to remove the fuel level lock ring on BMW/Mini E31, E34, E36, E38, E39, E46, E53, E60, E63, E64, E65, E83, E85, E90, R50, R52, R53, R55, R56 and R57 chassis.

- 1/2" Drive

#BMW7080SAC
Self-Adjusting Clutch Tool

Locating ring and clutch tensioner set used on BMW manual transmissions with Self-Adjusting clutch.

COMPARABLE: #212170 & #212180



#BMW6119F
Fuel Tank Lid Wrench

NEW!

Used to remove and install the metal fuel tank lid on BMW F01, F02, F25 & F30 Chassis.

- 1/2" Drive

COMPARABLE: #161190



**#BMW6208
Engine Timing Set**

Used to set timing on BMW N62, N62TU & N73 engines in BMW 545 [2004-2005], 550 [2006-2007], 550i [2008-2010], 645Ci [2004-2005], 650i [2006-2010], 745i [2003-2005], 745Li [2003-2005], 750i [2006-2008], 750Li [2006-2008], 760i [2005-2006], 760Li [2003-2008], Alpina B7 [2007-2008], X5 [2004-2010].

COMPARABLE: #119190, #119340, #119461, #119462 AND #119463.

**#BMW9054
Fuel Injector
Seal Set**

Set used to install new seals onto the injectors on BMW/Mini N14, N18, N54, N63 & N74 engines. Applicable to BMW 135is [2008-2010], 335i [2007-2010], 335xi [2007-2010], 535i [2008-2010], 535xi [2008-2010], 550i GT [2010-2013], 750i [2009-2013], 750Li [2009-2013], 760Li [2010-2014], X3 [2007-2010], X5 [2008-2013], X6 [2008-2013] and Mini Cooper [2007-2012].

COMPARABLE: #130192, #130193, #130194 AND #130195.

**#BMWMC280
Crankshaft Holder**

Used for crankshaft when releasing or tightening the central bolt on BMW N51/N52, Mini N12, N14, N16 and N18 engines.

COMPARABLE: #119280 & #83300493940

**#BMW11850
Head Bolt Socket**

Used on 3 of the head bolts on BMW N52, N54 and N55 engines. For all of the remaining head bolts on these engines use our #BMW11860.

- T-50
- 1/2" Drive
- 165mm Length

COMPARABLE: #114420

**#BMW11860
Head Bolt Socket**

Used on BMW N51, N52, N54 & N55 engines. Used in conjunction with #BMW11850.

- T-60
- 1/2" Drive
- 195mm Length

COMPARABLE: #118580



#BMW5585
Camshaft Bridge



Used in conjunction with #BMW3028 timing set on N55 engines. Applicable to BMW 335Cic [2011-2012], 335i [2011-2013], 335xi [2011-2012], 435i [2014-2016], 535i [2011-2017], 640i [2012-2018], 650i [2012-2013], 740i [2014-2015], 740Li [2014-2015], M235i [2014-2016], X1 xDrive 35i [2013-2013], X3 xDrive 35i [2011-2017], X4 xDrive M40i [2016-2018], X5 xDrive 35i [2011-2018] and X6 xDrive 35i [2011-2018].

COMPARABLE: #114285

 California Residents: Proposition 65
WARNING: See page 125 for info.

#BMW3028
Engine Timing Set

Engine alignment tools for newer BMW N51, N52 and N54 engine [2006-2012]. For N55 engines [2011-2018], use of #BMW5585 is required. Applicable to BMW 128i [2008-2012], 135i [2008-2012], 325i [2006], 325xi [2006], 328Cic [2007-2012], 328i [2007-2012], 328xi [2007-2012], 330i [2006], 330xi [2006], 335Cic [2007-2012], 335i [2007-2012], 335is [2011-2012], 335xi [2007-2012], 525i [2006-2007], 525xi [2006-2007], 528xi [2008-2010], 530i [2006-2007], 530xi [2006-2007], 535i [2008-2012], 535xi [2008-2010], X3 [2007-2012], X5 [2007-2012], X6 [2008-2012] and Z4 [2006-2012].

COMPARABLE: #110300, #114280, #114290 AND #118520.



#BMW2755
Intermediate Spring Tool

Used for removing and installing the pressure spring for the intermediate levers on BMW N20/N26/N52/N55 engines in BMW 135i [2011-2013], 135is [2013], 325i [2006], 325xi [2006], 330i [2006], 330xi [2006], 335Cic [2011-2012], 335i [2011-2014], 335xi [2011-2012], 525i [2006-2007], 525xi [2006-2007], 530i [2006-2007], 530xi [2006-2007], 535i [2011-2014], 640i [2012-2014], X1 35i [2013-2014], X3 35i [2011-2014], X5 35i [2011-2014], X5 35i [2011-2014], Z4 [2006-2008], 228i [2014-2016], 320i [2013-2018], 328i [2013-2016], 428i [2015-2016], 528i [2013-2016], X1 xDrive 28i [2013-2015], X3 xDrive 28i [2013-2015] and Z4 sDrive 28i [2012-2016].

COMPARABLE: #117110

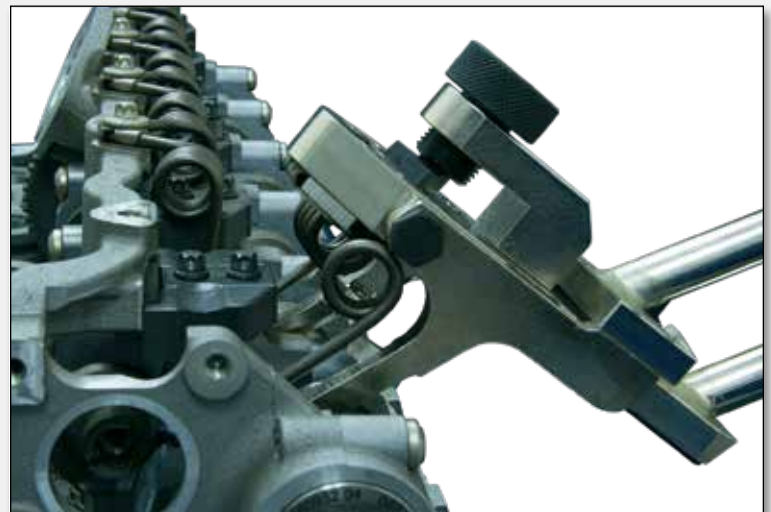

 California Residents: Proposition 65
WARNING: See page 125 for info.

#BMW2026
Engine Timing Set

Used for setting the timing on N20 & N26 2.0L turbo engines in BMW 228i [2014-2016], 320i [2013-2018], 328i [2013-2016], 428i [2015-2016], 528i [2013-2016], X1 xDrive 28i [2013-2015], X3 xDrive 28i [2013-2015] and Z4 sDrive 28i [2012-2016].

COMPARABLE: #2219548, #2212831, #2212830 AND #110300.



#BMW400-1
T.D.C. Locking Pin



Used for setting crankshaft T.D.C. in M21, M40, M41, M42, M43, M43TU, M44, M47, M47TU, M50, M51, M52, M52TU, M54, M56, M57, M57TU, M60, M62, M62TU, M70, M73, S50B30, S50B32, S54 & S62 engines.

COMPARABLE: #112300

#BMW6222
Chain Tensioner Tool



Used for tensioning the timing chain when adjusting the engine timing. Applicable to BMW/Mini N12, N14, N16, N18, N40, N42, N45, N46, N52, N54 and N62 engines.

COMPARABLE: #119340



#BMW400
Camshaft Alignment Set



Used for setting camshaft timing on M42, M44, M50, M52, M52TU, M54, M56, S50US & S52US engines [1991-2005].

COMPARABLE: #113240 AND #112300.



#BMW5254
Front Crank Seal Tool Set



SEAL REMOVER
MADE IN
THE USA

Used to loosen the seal for removal & installation of new front crank seals on BMW N52 & N54 engines [2006-2013]. When used in conjunction with #BMW9235 (Sold Separately), this set will also work for N55 engines [2011-2018].

COMPARABLE: #110370, #119220 AND #119230.

#BMW9235
Front Crankshaft Seal Adapter



Used to guide front crankshaft seal on N55 engines. Used in conjunction with #BMW5254.

COMPARABLE: #119235

NOTE: ONLY TWO BOLTS ARE USED

#BMW575190
Diesel HP Injection Pump Tool

NEW!



Used for removing camshaft sprocket from pump shaft when dismantling the injection pump VP44 and high-pressure pump common rail on BMW M57 engines [2009-2013].

COMPARABLE: #135190

#TA18
Brake Fluid Tank Adapter



Used for brake master cylinder or clutch master cylinder reservoirs. Used in conjunction with pressure bleeder.

- M46 x 3.5 Threads
- 1/4-18 NPT
- Air fitting not included



#CVB15
CV Clamp Crimping Tool



Used to crimp on clamps for CV boots on all BMW models with crimp style CV boots. Instead of squeezing together, drive the #CVB15 with your 3/8" drive ratchet to crimp these clamps.

DRIVE WITH A
3/8" RATCHET
(NOT INCLUDED)



#VW93005
Wire Terminal Extractor

Used to remove flat terminals with two tangs from the electrical connector plug (1mm Wide, 2.5mm Apart & 16mm Length).



#BMW2510
Brake Caliper Piston Tool

Used to reset the rear EMF adjustment unit and piston to the starting position. Must be used with standard 3/8" extension and ratchet. Applicable to BMW 528i [2011-2016], 535i [2011-2016], 550i [2011-2017], 640i [2012-2017], 650i [2012-2017], X3 [2011-2017] and Z4 [2010-2016].

- 3/8" Drive

COMPARABLE: #83302320299



#OFAUD1000
Euro 1/4 Turn Oil Funnel



Attaches directly to the valve cover, so when you're adding oil to the engine you don't have to worry about making a big mess due to the internal baffle of the valve cover of BMW engines [1993-2018].

- On some BMWs air intake may need to be removed.



#M0219
Oil Filter Wrench



Used on BMW motorcycles F650, F800, K100, K1100, K1200GT [2003-2004], K1200LT, K1200R, K1200RS [1996-2004], K1200S, K1300, K75, R1100, R1150, R1200C, R1200CL, R1200GSW [2013-2014], R850 and S1000RR.

- 74mm - 14 Flats
- Used with 22mm socket

California Residents: Proposition 65 WARNING. See page 125 for info.



#FUN14EURO
FUN14KIT Euro Adapter



Used in conjunction with #FUN14KIT. Attaches directly to the valve cover and so when you're adding oil to the engine you don't have to worry about making a big mess due to the internal baffle of the valve cover of BMW engines [1993-2018].



#BM1276
Oil Filter Wrench

Used on oil filters for BMW i3 "Range Extender" engine [2014-2018] and motorcycles F650F, F800GS, HP2, K1600 GTL/GT [2007-2016]; K1200GT; K1200R/SPORT, K1200S, R1200 ST, R1200GS, R1200R, R1200RT, R1200S, S1000 RR [2006-2008] with oil filter #11 42 7 673 541.

- 76mm - 12 Flutes
- 3/8" Drive



#H2760
Oil Drain Plug Wrench



Used for the R and R of the differential oil filler plug on many BMW models.



#V410
Oil Filter Wrench



Applicable to BMW models with N52, N54, N55 and N63 engines [2006-2017].

- 86.5mm - 16 Flats
- Used with 22mm socket

COMPARABLE: #119240

California Residents: Proposition 65 WARNING. See page 125 for info.



#ATF102
Universal ATF Adapter



Adapter used in conjunction with our ATF Filler System and is used on various BMW models.

#23236
32/36mm
Oil Filter Socket



Applicable to BMW 335d, X5 35d [2009–2011] and BMW 6 and 8 cylinder engines [1994–2005].

- Built Stocky for Better Access to Oil Filter Caps
- Stout Steel Construction
- 32mm x 36mm
- 3/8" Drive



#2175
Oil Filter Wrench



Applicable to BMW M44 engines.

- 74.5mm - 14 Flats
- Used with 22mm hex



 California Residents: Proposition 65 WARNING. See page 125 for info.

#2132
Oil Filter Socket

Applicable to BMW 335d, X5 35d [2009–2011] & X5 xDrive 35d [2011–2013]. Also fits 230i 330i, 340i, 530i, 740i, M240i & X1 [2017 & Newer].

- 32mm - 6 Flats
- 3/8" Drive



#ATFBASIC
Basic Driveline Filler



ATF CONTAINER
MADE IN USA

Used for filling fluids in transmission, differentials and transfer cases (not suitable for use with fuels or solvents). Individual manufacturer sets are available as well as the individual adapters. Container made of UHDP (ultra high density polyethylene). Newly designed drum features a second port for filling or dumping fluids without having to remove the pump—saving both time and clean up afterwards.

#2101
7-Piece Oil Filter
Wrench Set



For many domestic and foreign applications. The 27mm, 32mm, 36mm hex sizes and the four, cup-style wrenches cover many BMW engines.

 California Residents: Proposition 65 WARNING. See page 125 for info.



#2124
Oil Filter Socket

Used for R & R of the oil filter housing cap of N62/ N62TU engines [2002-2010].

- 24mm - 6 Flats
- 3/8" Drive



#2136
Oil Filter Socket

Used for R & R of oil filter housing caps on M52, M54, M60, M62, M70 and M73 engines and Mini Cooper S [2002-2006].

- 36mm - 6 Flats
- 3/8" Drive



#MSP1412
Magnetic Spark Plug Socket



Used to remove spark plugs on BMW engines N20, N26, N54, N55 and N63 [2007-2018] and turbocharged Mini Cooper engines [2007-2015].

- 14mm - 12 Point
- 3/8" Drive
- Strong internal magnet holds spark plug firmly

NOTE: SPARK PLUG SOCKET IS SLENDER IN DESIGN TO FIT APPLICATION.

COMPARABLE: #121220



#SP1412
Spark Plug Socket



Used to remove spark plugs on BMW engines N20, N26, N54, N55 and N63 [2007-2018] and turbocharged Mini Cooper engines [2007-2015].

- 14mm - 12 Point
- 3/8" Drive
- Rubber boot to hold spark plug

NOTE: SPARK PLUG SOCKET IS SLENDER IN DESIGN TO FIT APPLICATION.

COMPARABLE: #121220



#H2223LGT-30
Torx Socket Insert



Used for the R & R of the airbag from the steering wheel. Applicable to many older BMW models.

- T-30
- 70mm Length



#6500TL-80
Torx Socket

NEW!

Used on BMW for R & R of driver's side wiper arm on E31, E38 and E39 chassis. Also fits Lamborghini wheel lug bolts on Gallardo models.

- T-80 Tamper-proof
- 1/2" Drive
- 100mm Length



#201-7
5-Piece Metric Stud Puller Set

5-Piece metric stud remover set. Ideal for BMW manifold studs. Includes 6mm, 7mm, 8mm, 10mm and 12mm stud remover tools.

WARNING: California Residents: Proposition 65. See page 125 for info.



#BMW377
Allen Socket



Used for easy removal of the rear brake caliper slide bolts on BMW E36, E46, E39 and E31 models.

- 7mm
- 3/8" Drive
- 32mm Length

#200-7
7mm Stud Remover and Installer

7mm Stud remover and installer. Ideal for BMW manifold studs.

WARNING: California Residents: Proposition 65. See page 125 for info.



**#BMW4053-1
PDC Drill Bit**

NEW!

Used for drilling starting holes for the #BMW4053-2



**#BMW4053-2
PDC Punching Tool**

NEW!

Used for cutting holes for the Parking Distance Control sensors into BMW replacement bumpers.

COMPARABLE: #83302334055



**#BMW11845
Torx Socket**

Used for BMW VANOS housing bolts.

- T-45 Tamper-proof
- 3/8" Drive
- 100mm Length



**#BMW432
VANOS Solenoid Socket**



Used for removing and installing the VANOS solenoid valves on M52TU, M54 & M62TU engines [1999–2005].

- 32mm - 6 point
- 1/2" Drive

COMPARABLE: #116420.



**#MC560
Rear Caliper
Brake Piston Tool**



Used with a universal 3/8" brake caliper piston tool. Used on all Mini Cooper models [2007–2013] (except Countryman). For [2002–2006] Mini Cooper, see #V450.

- 3/8" Drive

COMPARABLE: #346309

**#BFLT60
Flywheel
Socket Tool**



For R & R of flywheel bolts. Applicable to E34 and E39 V8 4.0L, 4.4L and 5.0L with standard transmission.

- T-60
- 1/2" Drive
- 140mm Length

COMPARABLE: #114180

**#V450
Brake Caliper
Piston Adapter**



Used for turning in the rear brake caliper piston on Mini Cooper [2002– 2006].

- 3/8" Drive

COMPARABLE: #346301.

**#MC240
Window Wrench**



Hook wrench used for adjusting the door window glass to fit BMW and Mini [2002–2013].

COMPARABLE: #513240

 California Residents: Proposition 65 WARNING. See page 125 for info.

**#100-30A
12-Point Deep Socket**

Used for R & R of transmission drive shaft flange nut and pinion shaft flange nut of differential. Applicable to many BMW models including E90 325 (RWD) 30mm axle nuts.

- 30mm
- 1/2" Drive
- 85mm Length
- Thin-walled



**#BMW10160
Extra Long
10mm Socket**



Used for R and R of the ground connector screw for the injector on BMW N54 engines.

- 1/4" Drive
- 160mm Length

COMPARABLE: #118620



#MC1400-1
Mini Flywheel Locking Pin

Used for locating the crankshaft in T.D.C. position. Included in #MC1216SET, #MC1400 and #MC1800 timing set. Applicable to Mini [2007-2015].

COMPARABLE: #119590



#ATF105
ATF Adapter

Used on Mini Cooper with "AISIN" transmission in conjunction with the #ATFBASIC. (This will not thread into the CVT Transmission.)

- M10 x 1.0 Threads



#ATFSU100
Universal ATF Attachment



Used on Mini Cooper CVT models with restricted access to transmission fill tube. Used in conjunction with the #ATFBASIC.



#MCB4648
Engine Timing Set

NEW!



Used for setting engine timing for BMW and Mini new B38, B46 and B48 engines. Applicable to BMW models [2016-2018] and Mini Cooper models [2014-2018].

COMPARABLE: #116480, #118580, #119340, #2358122, #2288380, #2360895, AND #2365488.



#MC1216SET
Camshaft
Alignment Tool



Used to set timing on N12 and N16 (non-turbo) engines in Mini Cooper [2007-2013], Clubman [2008-2014], Convertible [2009-2015], Countryman [2011-2016], Paceman [2014-2016], Roadster [2013-2015], Coupe [2012-2015] and Coupe JCW [2012-2012].

COMPARABLE: #119540, #119340 AND #119590

#MC1800
Engine Timing Set



Used to set timing on Mini Cooper N18 turbo charged engines in Cooper JCW [2013-2013], Cooper JCW Clubman [2013-2014], Cooper JCW Convertible [2013-2015], Cooper JCW Countryman [2013-2016], Cooper JCW Paceman [2014-2016], Cooper JCW Roadster [2013-2015], Cooper S [2011-2013], Cooper S Clubman [2011-2014], Cooper S Convertible [2011-2015], Cooper S Countryman [2011-2016], Cooper S Countryman ALL4 [2013-2016], Cooper S Paceman [2014-2016], Cooper S Paceman ALL4 [2014-2016], Cooper S Roadster [2013-2015], Coupe JCW [2013-2015] and Coupe S [2012-2015].

COMPARABLE: #117440, #119340 AND #119590



#MC1400
Engine Timing Set



Used to set the timing on N14 turbocharged engines in Mini Cooper JCW [2009-2012], Cooper JCW Clubman [2009-2012], Cooper JCW Convertible [2009-2012], Cooper S [2007-2010], Cooper S Clubman [2008-2010] and Cooper S Convertible [2009-2010].

COMPARABLE: #119550 AND #119590



#MC9570
Intermediate Lever Tools



Used for removing and installing the Intermediate Levers on Mini Cooper N12 and N16 engines [2007-2016].

COMPARABLE: #119570, #119571, #119572 AND #119573.

#TM1215
Ball Joint Hammer Nut

NEW!

Used for breaking free steering knuckle/ suspension joints using an impact hammer. Nut must be threaded all the way onto knuckle/ suspension joints threaded shafts.

- M12 x 1.5 Threads
- 22mm - 7/8" Hex



NOTE: FOR THE COMPLETE 4PC. SET, PURCHASE THE #TM20194 CONTAINING M12X1.25, M12X1.5, M14X1.5 AND M16X1.5.

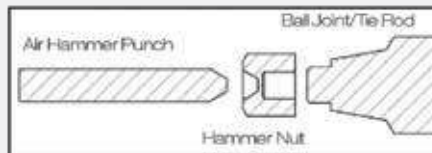

#TM1415
Ball Joint Hammer Nut

NEW!

Used for breaking free steering knuckle/suspension joints using an impact hammer. Nut must be threaded all the way onto knuckle/ suspension joints threaded shafts.

- M14 x 1.5 Threads
- 22mm - 7/8" Hex



#2127
Oil Filter Socket

Used to remove oil filters on BMW 535d [2014-2015], 740Ld xDrive [2015-2015], X5 35d xDrive [2014-2015] and Mini Cooper models [2007-2015].

- 27mm - 6 Flats
- 3/8" Drive



#MC11419
Serpentine Belt Wrenches



Serpentine belt wrenches for Mini models equipped with N12, N14, N16 and N18 engines. Each set comes with one large and one small 12-point wrench. If needed, you can use 1/2" drive ratchet to help with indexing the wrench onto the tensioner and for compressing the tensioner back.

COMPARABLE: #116210

- Only sold as a pair

WARNING: California Residents: Proposition 65. See page 125 for info.

#MC100
Serpentine Belt Tool

Serpentine belt tool used for relieving tension on belt tensioner on [2002-2006] Mini Cooper "S" Supercharger equipped models.

COMPARABLE: #118410



#JLR5008
Engine Timing Set



Used on Jaguar / Land Rover models with the 3.0L & 5.0L engines in Jaguar F-Type [2014-2016], XE [2016-2016], XF [2010-2016], XJ [2010-2016], XK [2010-2015]; Land Rover LR4 [2010-2016], Range Rover [2010-2016] and Range Rover Sport [2010-2016].

COMPARABLE: #303-1447, #303-1452, #303-1445, #303-1482, #303-1448 AND #JLR-303-1303.



#V3032
Engine Timing Set

Used for setting timing of Land Rover LR2 [2008-2012].

COMPARABLE: #9997257, #9997261, #9997263, #9997264, #9997271 AND #9997272.



CRANKSHAFT ALIGNMENT DISC MADE IN USA.

#JLR20T
Timing Tools

NEW!

Applicable to Land Rover Evoque and Jaguar XF RWD [2013-2017]. Included are the Flywheel locking Block, Crankshaft Positioner Plate and T.D.C. Crank locking Pin.

- Must be used in conjunction with #F20T.

COMPARABLE: #303-1594, #303-1595 AND 303-748.



#F20T
Engine Timing Set

Set includes the T.D.C. crank timing pin, cam locking plate and the crank position sensor (CPS) alignment block for Land Rover Evoque and Jaguar XF RWD [2013-2017].

- Must be used in conjunction with #JLR20T.

COMPARABLE: #303-507, #303-1521 AND #303-1565.



**#JLR5037
Crankshaft
Holding Tool**

Used on Jaguar / Land Rover models with the 3.0L & 5.0L engines [2010-2017].

- Must be used in conjunction with #JLR5038.

COMPARABLE: #303-1437

**#JLR5038
Crankshaft
Bolt Socket**

Used on Jaguar / Land Rover models with the 3.0L & 5.0L engines [2010-2017].

- Must be used in conjunction with #JLR 5037
- 24mm - 6 point
- 3/4" Drive

COMPARABLE: #303-1438

**#JAS6514
Oil Filter Wrench**

Used on Jaguar 2.0L Diesel [2017-2018]; Land Rover Evoque [2018] and Range Rover Velar [2018].

- 65mm - 14 Flats
- 3/8" Drive

**#JA19015
Oil Filter Wrench**

Applicable to Jaguar XF [2010-2017], XFR [2010-2016], XJ [2010-2017], XJL [2010-2016], XK [2010-2016], XKR [2010-2016]; Land Rover LR4 [2010-2017], Range Rover [2010-2017], Range Rover Sport [2010-2017] and Range Rover Velar [2018] with the 3.0L v6 and 5.0L v8 engines [2010-2017].

- 90mm - 15 Flats
- 3/8" Drive

**#M0219
Oil Filter Wrench**

Applicable to Jaguar XE [2017] and XF [2013-2017]; Land Rover Evoque [2013-2015] 2.0L Turbo engines.

- 74mm - 14 Flats
- Used with 22mm socket

California Residents: Proposition 65 WARNING. See page 125 for info.

**#2132
Oil Filter Socket**

Used on Land Rover Range Rover 3.0L Diesel engine [2016-2017].

- 32mm - 6 Flats
- 3/8" Drive

**#OFFM2012
Engine Oil Funnel**

Attaches directly to the engine oil filler neck or valve cover. Used on Jaguar XF [2013-2017] and Land Rover Evoque [2012-2017] and LR2 [2013-2015]. Made of durable ABS.

- **DO NOT USE BRAKE CLEAN**

California Residents: Proposition 65 WARNING. See page 125 for info.

**#OFGMRD08
Engine Oil Funnel**

Used on Jaguar S Type, X-Type [2000-2008], F-Type, XF, XFR, XJ, XJR, XK, XKR [2010-2017]; Land Rover LR4, Range Rover and Range Rover Sport [2010-2017].

- **DO NOT USE BRAKE CLEAN**
- Made of strong polycarbonate
- Attaches directly to the engine oil filler neck or valve cover

California Residents: Proposition 65 WARNING. See page 125 for info.

**#OFHON1033
Engine Oil Funnel**

Used on Jaguar and Land Rover models with the 4.2L V8 engine [2002-2009].

- **DO NOT USE BRAKE CLEAN**
- Made of durable ABS plastic
- Attaches directly to the engine oil filler neck or valve cover

California Residents: Proposition 65 WARNING. See page 125 for info.



**#BMW345
Tank Adapter**



Used to pressurize coolant reservoirs in Land Rover Discovery [1999-2004] and Range Rover [1995-2004].

- M51 x 4 threads



**#FZ36
Cap Adapter**



Used to test coolant tank cap. Applicable to Jaguar F-Type, S-Type, X-Type, XF, XJ, XK [2003-2017]; Land Rover Discovery Sport, Range Rover, Freelander, LR3, Range Rover Sport [2005-2017].

- M52 x 2.5 threads



**#FZ25
Tank Adapter**



Applicable to Land Rover Freelander [2002-2004].

- M47 x 3 threads



**#V450
Brake Caliper Piston Adapter**



Used for turning in the rear brake caliper piston on Jaguar S-Type.

- 3/8" Drive



**#FZ32A
Tank Adapter**



Applicable to Jaguar F-Type, S-Type, X-Type, XF, XJ, XK [2003-2017]; Land Rover Discovery Sport, Range Rover, Freelander, LR3, Range Rover Sport [2005-2017].

- M52 x 2.5 threads



**#JLR9899
Fuel Injector Seal Tools**



NEW!

Used to replace the Teflon seals on the direct injection fuel injectors on Jaguar and Land Rover models with the 3.0L v6 and 5.0L v8 engines. [2010-2017].

- Use #JLR0197 to remove the injectors

COMPARABLE: #310-198 AND #310-199



**#FZ47
Tank Adapter**



Applicable to Land Rover Evoque [2012-2017] and LR2 [2007-2015].

- M49 x 2.5 threads



**#JLR0197
Fuel Injector Puller**

Used to remove the fuel injectors on Jaguar and Land Rover models with the 3.0L v6 and 5.0L v8 engines. [2010-2017].

- Must be used in conjunction with #JLR9899 if replacing the seals.

COMPARABLE: #310-0197

 California Residents: Proposition 65 WARNING. See page 125 for info.



**#M7226
Transmission Dipstick**

Used in Jaguar models with W5A580, Jaguar XKR [2000-2002].

COMPARABLE: #307-379



**#100-30A
12-Point
Deep Socket**

Used for R and R of transmission drive shaft flange nut and pinion shaft flange nut of differential on Mercedes models.

- 30mm
- 1/2" Drive
- 85mm Length
- Thin-walled



**#M8160
Long 8mm
Socket**



Used for R&R of rear tail light assembly on Mercedes [2017-2018].

- 1/4" Drive
- 160mm Length



**#M17XLWS
Lug Nut Socket**

Used to R & R the "Flower Shaped" lug nut on Maybach and Mercedes 221 S-class and late model CL-class.

- 1/2" Drive
- 86mm Length

FITS LUG BOLT #000 990 5407



**#MOE24
E24 Impact Socket**

Used on front axle nut on Mercedes C 230, C 300, C 350 [2008–2009], C 250, C 300, C 350 [2010–2011], C 300, C 350 [2012–2014], C 350 [2015], E 350, E 550 [2010–2014], E 350 [2015–2016] and S 550 [2007–2013].

- 1/2" Drive
- 78mm Length



**#BMW10160
Long 10mm Socket**



Used to remove Mercedes rear bumper securing nuts.

- 1/4" Drive
- 160mm Length



**#M17WLS
Lug Nut Socket**

Used to R & R the "Flower Shaped" lug bolt on Maybach and Mercedes 221 S-class and late model CL class.

- 1/2" Drive
- 50mm Length

FITS LUG BOLT #000 990 5407.



**#ALT34018
Alternator
Pulley Socket**

NEW!

Used for R and R of the free-wheel pulley on the alternator on newer Bosch Alternators.

COMPARABLE:
#602589001000



**#M2039
Shock
Crown Socket**

Used for the R and R of shock absorber nut on Mercedes C-Class & CLK [2001-2009].

COMPARABLE:
#203589000700



**#H2223LGT-30
Torx Bit**



Used for the R & R of the airbag from the steering wheel on various Mercedes models [1998–2002].

- T-30
- 70mm Length



**#6500TPT-100
Torx Socket**

Used to remove and replace the camshaft adjuster central valve on Mercedes 274, 276, 270, 278 and 271 engines [2012-2016].

- T-100 Tamper-proof
- 1/2" Drive
- 95mm Length

COMPARABLE: #271589001000



**#6500T-100
Torx Socket**

Used to remove the plug for accessing the parking pawl detent on the 722.9 Mercedes transmissions.

- T-100
- 3/4" Drive
- 60mm Length



**#M820
Glow Plug Socket**

Applicable to glow plugs on Mercedes and Sprinter.

- 8mm
- 3/8" Drive



**#6300T-50
Torx Socket**

NEW!

Used on Mercedes alternator pulley bolts.

- T-50
- 3/8" Drive
- 73mm Length



**#2127
Oil Filter Socket**

Used on Mercedes C 300 [2015].

- 27mm - 6 Flats
- 3/8" Drive



**#2136
Oil Filter Socket**

Used on Mercedes diesel engines OM604, OM605 and OM606.

- 36mm - 6 Flats
- 3/8" Drive



**#2101
7-Piece Oil Filter Wrench Socket Set**



Includes oil filter wrench sockets for many domestic and foreign applications.

- This set covers all Mercedes applications by using 2127, 2136, M0219 and M0284.



 California Residents: Proposition 65 WARNING. See page 125 for info.

**#M0284
Oil Filter Wrench**



Used for Mercedes vehicles equipped with 3.0L V6 CRD (Common Rail Diesel) engines.

- 84mm - 14 Flats
- Used with 22mm socket



 California Residents: Proposition 65 WARNING. See page 125 for info.

**#M0219
Oil Filter Wrench**



Used for Mercedes engines M113, M276, M285, M120, M104, M155, M112, M273, M275, M119, M137, M111, M272 and Sprinter (gas engine) [1998–2015].

- 74mm - 14 Flats
- Used with 22mm socket

COMPARABLE: #103589020900



 California Residents: Proposition 65 WARNING. See page 125 for info.

**#2175
Oil Filter Wrench**



Used to remove oil filter on Mercedes C 350, C 400, E 250, GLK 250, ML 250 [2014-2016], Sprinter 2.7L [2003-2006] and Sprinter 2.1L [2014–2016].

- 74.5mm - 14 Flats
- Use with 22mm socket



 California Residents: Proposition 65 WARNING. See page 125 for info.

**#MB4517
Injection Line Wrench**



Used on Mercedes Diesel fuel injection lines.

- 3/8" Drive

**#M1620
Motor Mount Wrench**



Used to loosen bolt on the motor mount Mercedes 272 and 273 engines [2002-2008].

- 3/8" Drive

**#H2760
Oil Drain & Plug Wrench**



Used for the R and R of the differential oil filler plug on many Mercedes-Benz models.

**#MVW2050F
Fuel Line Pliers**



Used for fuel lines with plastic snap-together connectors found on Mercedes ML 320 and ML 430 [1998-2005] fuel filters.

COMPARABLE: #163589003700

**#TM1215
Ball Joint Hammer Nut**

NEW!

Used for breaking free steering knuckle/suspension joints using an impact hammer. Nut must be threaded all the way onto knuckle/suspension joints threaded shafts.

- M12 x 1.5 Threads
- 22mm - 7/8" Hex



NOTE: FOR THE COMPLETE 4PC. SET, PURCHASE THE #TM20194 CONTAINING M12X1.25, M12X1.5, M14X1.5 AND M16X1.5.

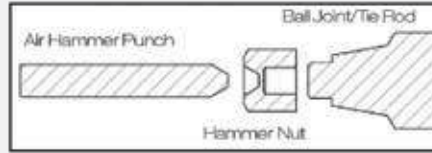

**#TM1415
Ball Joint Hammer Nut**

NEW!

Used for breaking free steering knuckle/suspension joints using an impact hammer. Nut must be threaded all the way onto knuckle/suspension joints threaded shafts.

- M14 x 1.5 Threads
- 22mm - 7/8" Hex



**#FZ32A
Tank Adapter**



For pressurizing cooling system on Mercedes ML 320 and ML 430 [1998-2005].

- M52 x 2.5 Threads

**#MB164251
Fuel Pump Wrench**

Used for R & R of the fuel pump on Mercedes 164 and 251 chassis [2006-2014].

- 1/2" Drive

COMPARABLE: #164589010700



California Residents: Proposition 65
WARNING: See page 125 for info.

**#FZ55
Tank Adapter**



Cooling system pressure tester adapter. Applicable: Dodge / Freightliner / Mercedes Sprinter vans [2007-2019].

- M46 x 2.5 Threads



**#FZ36
Cap Adapter**



Used to test coolant tank cap on Mercedes ML 320 and ML 430 [1998-2005].

- M52 x 2.5 Threads

**#M034919
Tank Adapter**



Used for pressurizing the cooling system on various Mercedes models [1996 - 2019].

- M62 x 4 Threads
- For ML models [1998-2005], see #FZ32A.



#FUN14EURO
FUN14KIT
Euro Adapter



Used in conjunction with #FUN14KIT. It attaches directly to the valve cover, so when you're adding oil to the engine you don't have to worry about making a big mess due to the internal baffle of the valve cover of Mercedes engines [1993-2016].

- May not fit applications where cowl causes interference.



#OFAUD1000
Euro 1/4 Turn
Oil Funnel



Attaches directly to the valve cover, so when you're adding oil to the engine you don't have to worry about making a big mess due to the internal baffle of the valve cover of Mercedes engines [1993-2016].

- May not fit applications where cowl causes interference.



#M0721
Engine Oil Dipstick

Used for checking engine oil level on Mercedes models with 112, 113, 137 and 271 engines that do not have an engine dipstick.

COMPARABLE: #120589072100

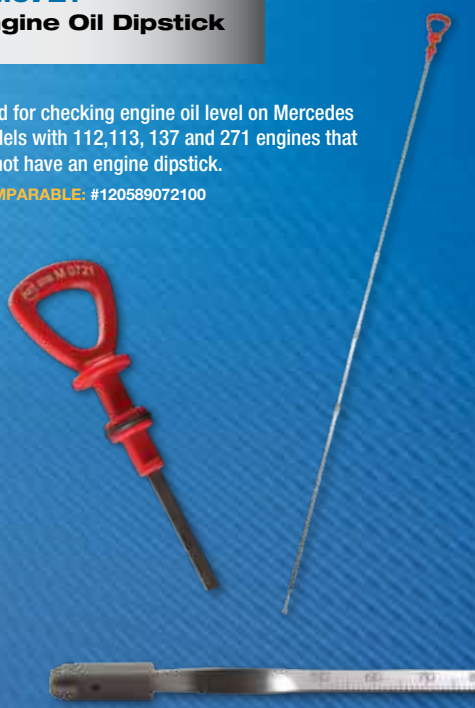

#M7226
Transmission Dipstick

Used for checking ATF level in Mercedes models with the 722.6 transmission [1997-2006].

COMPARABLE: #140589152100



#M21250
Transmission Dipstick

Used for checking ATF level in Mercedes CLA and GLA models with the 724 Transmission [2014-2017].

COMPARABLE: #168589012100



**#ATFMB
Driveline Filler**

Used for filling transmission fluid in Mercedes 722.9 automatic [2004-2018].

- For 724 transmission, see #M21250.
- For 725 transmission, see #ATFMB725.

NOT SUITABLE FOR USE WITH FUELS OR SOLVENTS.



**#ATF129
ATF Filling Adapter**



Used for filling transmission fluid in Mercedes 722.9 automatic [2003-2018].

- For 725 Transmissions, see #ATFMB725

**#S3054X-10
Head Bolt
Socket**



Used for R and R of cylinder head bolts. Applicable to Mercedes OM 601, OM 602 and OM 603 engines.

- 10mm
- 1/2" Drive
- 140mm Length

COMPARABLE: #601589001000



**#S3054X-12
Head Bolt
Socket**



Applicable to Mercedes head bolts on OM 6 15, 616, 617, M 102 and M 103 engines.

- 12mm
- 1/2" Drive
- 140mm Length

COMPARABLE: #617589001000



**#ATFMB725
Transmission Filling
Adapter Set**

NEW!

Used for filling the Mercedes 725 transmissions [2014-2019]. Used in conjunction with #ATF129 adapter and one of our ATF Filling Units.



**#M0333
Instrument Cluster Puller**

Used for R and R of the instrument cluster on Mercedes 107, 116, 123, 124, 126, 129, 140, 168, 170, 201, 202, 208, 210 and 463 chassis.

COMPARABLE: #110589005900



**#M27161
Camshaft Alignment
Fixture**

Camshaft alignment fixture for Mercedes C 230 [2003-2005], C 250 [2012 - 2015] and SLK 250 [2012-2015].

COMPARABLE: #271589006100



**#3206
Door, Trim and
Molding Tool Set**

Set includes a T-25 long Torx screwdriver Shank Length 10 inches for accessing door handles on various Mercedes models. One trim spoon and one light duty hook is included for various interior jobs. Includes one pair of trim and cluster hooks. Three soft wedges are also included for various trim and molding jobs both for interior and exterior applications. Includes carrying pouch.



#OFAUD1000
Euro 1/4 Turn Oil Funnel



Specifically designed to attach to the valve covers. When adding oil to the engine you don't have to worry about making a mess due to the internal baffle of the valve cover. Applicable: Volvo 2.5L engines.



- May not fit applications where cowl causes interference.

#CVB15
CV Clamp Crimping Tool

Used to crimp on clamps for CV boots on all Volvo models with crimp style CV boots. Instead of squeezing together, drive the #CVB15 with your 3/8" drive ratchet to crimp these clamps.

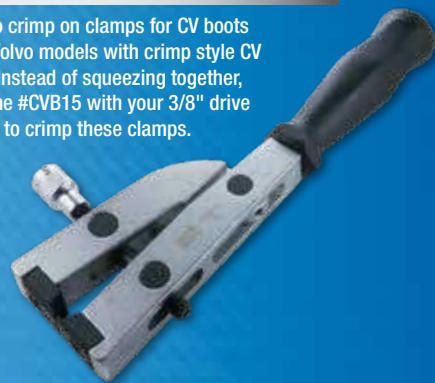

#V500
Cam and Crankshaft Alignment Set



CAMSHAFT AND CRANKSHAFT TIMING FIXTURES MADE IN USA

Used for the alignment of the camshafts and crankshafts on all in-line (4, 5 and 6-cyl.) twin cam motors through 2011, except the 3.0L and 3.2L. May also be used to align the camshafts with the cam cover.

COMPARABLE: #9995451, #9995452, #9995453 AND #9995454.

#MSP1412
Magnetic Spark Plug Socket



Applicable to Volvo models S60 [2016-2018], S60 Inscription [2016-2018], S60 Cross Country [2017-2018], S60 Polestar [2017-2018], S60 R Design [2017-2018], S80 [2016], S90 [2017-2018], V60 [2016-2018], V60 Cross Country [2017-2018], V60 Polestar [2017-2018], V60 R Design [2017], V90 [2017-2018], V90 Cross Country [2017-2018], XC60 [2016-2018], XC60 R Design [2016-2018], XC70 [2016] and XC90 [2016-2018].

- 14mm - 12 Point
- 3/8" Drive
- Strong internal magnet holds spark plug firmly



#SP1412
Spark Plug Socket



Applicable to Volvo models S60 [2016-2018], S60 Inscription [2016-2018], S60 Cross Country [2017-2018], S60 Polestar [2017-2018], S60 R Design [2017-2018], S80 [2016], S90 [2017-2018], V60 [2016-2018], V60 Cross Country [2017-2018], V60 Polestar [2017-2018], V60 R Design [2017], V90 [2017-2018], V90 Cross Country [2017-2018], XC60 [2016-2018], XC60 R Design [2016-2018], XC70 [2016] and XC90 [2016-2018].

- 14mm - 12 Point
- 3/8" Drive
- Rubber boot to hold spark plug



#V3032
Engine Timing Set

Used to set timing on 3.0L /3.2L engines in Volvo S60 [2011-2013], S60 R [2012-2013], S80 [2007-2013], V70 [2008-2010], XC60 [2010-2013], XC60 R [2012-2012], XC70 [2008-2013], XC90 [2007-2013], XC90 R [2012-2013]. Crankshaft alignment disc made in USA.

COMPARABLE: #9997257, #9997261, #9997263, #9997264, #9997271 AND #9997272.



**#VB414
Oil Filter Wrench**



Fits Volvo 2.0L turbo models.
Applicable: Volvo S60, S80, V60, XC60 and XC70 [2015–2019].

- 16 Flats
- Use with 22mm socket



California Residents: Proposition 65
WARNING: See page 125 for info.

**#V410
Oil Filter Wrench**



Used for all Volvo models [1999–2006] (except 2005 40 & 50 Series).

- 86.5mm - 16 Flats
- Use with 22mm socket

COMPARABLE: #9995679



California Residents: Proposition 65
WARNING: See page 125 for info.

**#2136
Oil Filter Socket**

Applicable:
[2007–2014] Volvo models with 36mm hex molded into the oil cap.

- 36mm - 6 Flats
- 3/8" Drive



**#ALT34018
Alternator Pulley Socket**



Used for R & R of the free-wheel pulley on the alternator. Used in conj. with #S 3054 X-10 or #6300 T-50 sockets. Applicable: Volvo C70, S40, S60, S70, S80, V50, V60, V70, V70 XC, XC60, XC70, XC90.

COMPARABLE: #9995760



**#FZ22
Tank Adapter**



For pressurizing cooling system. Applications: Volvo trucks with M48 x 3 threads on filler neck. Applicable to [2005] Volvo V670 and VN430.

- M48 x 3 Threads



**#FZ25
Tank Adapter**



For pressurizing cooling system. Applicable: [1978–2007] Volvo passenger vehicles with threaded neck and Volvo trucks with M47 x 3 threads on secondary filler neck (except S40 and V50).

- M47 x 3 Threads



**#ATF108V
ATF Adapter**



Driveline filler adapter. Applicable to some Volvo models [2007–2018] 6 speed and 8 speed Automatic transmissions with out a fluid dipstick. Used to fill using the 5/16" x 24 threaded plug.

- 5/16-24 Threads



**#EU2090
Allen Socket**

Brake caliper socket Applicable to Volvo front caliper slide bolts [2010–2015].

- 9mm
- 3/8" Drive
- 52mm Length



**#V450
Brake Caliper Piston Adapter**



Used for turning in the rear brake caliper piston on Volvo 40 and 50 Series.

- 3/8" Drive



**#V5720
Fuel Tank Locking Ring Tool**



Applicable: Volvo V70 [2000–newer], S80, XC90, S60, V70 XC (2001–newer) / XC70. Used on the following engines: B5204T5, B5234T3, B5244S, B5244S6, B5244SG, B5244SG2, B5244T3, B5244T5, B5254T2, B5254T4, B5254T9, B6284T, B6294S, B6294S2, B6294T, B6304S3, B6324S, B6324S5, B8444S, D5244T, D5244T18, D5244T4 and D5244T5.

- 1/2" Drive

COMPARABLE: #9995720



**#FZ47
Tank Adapter**



Used for pressurizing the coolant system on Volvo S40 [2004.5–2010], S60 [2010–2018], S80 [2008–2016], S90 [2018], V50 [2005–2012], V60 [2015–2018], XC60 [2010–2018], XC70 [2008–2016] and XC90 [2016–2018].

- M49 x 2.5 threads



#T10389
Assembly Tool

For removal and installation of the lock cylinder housing on doors with no lock cylinder. Applicable: VW Tiguan [2009-2016]. Included in #3206 set.



#3035
3.5mm Socket

Used for R & R of the Proximity (Radar)Sensors and any place a 3.5mm socket is needed.

- 1/4" Drive
- 25mm Length



#VW93005
Connector Release Tool

Used to remove flat terminals with two release tangs from the connector plug (1mm wide, 2mm apart and 16mm long).



#T10518A
Grab Handle Release Tool

Used to remove the roof grab handle of the Golf [2013-2017] and Tiguan [2016-2017] without causing damage.



#3316
Radio Removal Keys



For removing the factory-installed radio. Applicable: new body style VW Passat [1999-2005] and Jetta and Golf [1999-2005] with vertically aligned key slots.

#3344A
Radio Removal Tool



For radio removal on Audi A4, A6, A8 and VW new Beetle models with horizontally aligned key slots. Two pair required in most cases.

COMPARABLE: #T10057

#VW20T
Engine Timing Set

For VW/Audi models with 2.0L (turbo) [2009–2017].

COMPARABLE: #T10352, #T10352-1, #T10355, #T10368, #T40011, #T40196, #T40267 AND #T40271.

- Sometimes requires the use of additional tool #T 40243

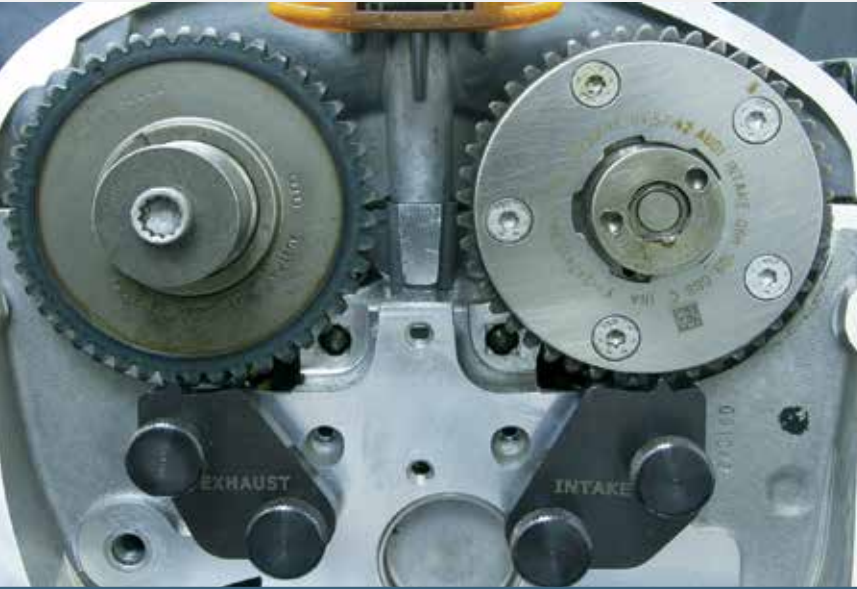

#T4306
Engine Timing Set

Used to hold and align the camshafts on Audi 3.0L engines in A4 [2002–2005] and A6 [2002–2004].

COMPARABLE: #T40011, #T40026, #T40028 AND #T40030.

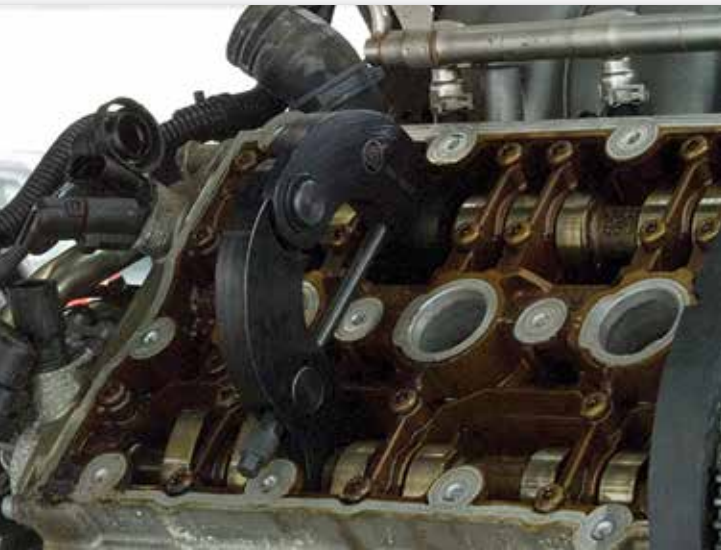

#3359
TDI Injector Pump
Locking Pin



Used on VW TDI engines [1999–2014].
Locks cam on 1.9L (BEW and BRM).
Also used on newer VW 2.0L turbo diesel
(CBEA, CKRA and CJAA).
For 2009–Newer, two #3359 pins are required.



#6814TDI
TDI Timing Belt Tools

Used on VW TDI engines [1999–2014]. Locks cam on 1.9L (BEW and BRM).
Also used on newer VW 2.0L turbo diesel (CBEA, CKRA and CJAA).

- Set includes 2 of the #3359.



#3428
TDI Cam Lock Bar



For locking the camshaft on VW TDI without removing the valve cover [1999–2003]. Replaces the old style #3418. Used in conjunction with #3359.
COMPARABLE: #T10098A

#T40079
Timing Chain Adjuster

Used to tension the Timing Chain via the Camshaft Adjuster on 3.0L V6 Supercharged (CGXB & CTUA) and 4.2L V8 4v (BAR, BNS, BVJ, CAUA) engines in Audi A7 [2012-2015], A8/A8L [2007-2009], Q7 [2007-2009], RS4 [2007-2008] and S5 [2008-2009].

- Use with 24mm or 15/16" socket

California Residents: Proposition 65
WARNING. See page 125 for info.



#3366
Bracket for Chain Adjuster

For removing and installing the timing chain adjuster. Applicable: VW/Audi 4-cyl., 6-cyl. and 8-cyl. (5v) engines.



#T40243
Chain Tensioner Lever



Used for slackening the Chain Tensioner when detaching the Timing Chain from the Camshaft. Applicable to 2.0L 4-Cylinder turbo TFSI (CAEB) engine.

- Used in conjunction with #VW20T.

#T40267
Locking Clips



Locking clips for chain tensioner. Applicable to 2.0L 4-cyl. (4v) turbo TFSI (CAEB) engine (Generation III).



#VW87-2
Timing Belt Spanner Wrench

For adjusting the timing belt tension. Applicable: VW Golf, Jetta, Passat [1999–later] and VW Beetle with 2.0L gas engine and 1.9L TDI diesel engine [1999–2003].

COMPARABLE: #T10020



#VW87-1
Timing Belt Spanner Wrench

For the adjustment of the timing belt. Applicable: VW Golf, Jetta Pumpe-Duse [2004–2005] and Audi 3.0L V6 [2002–2005].

COMPARABLE: #3387



#H2587
Spanner Wrench



For adjusting the tension of the timing belt. Applicable: [through 1998] 4-cyl. VW Golf and Jetta, [through 1997] 4-cyl. VW Passat, Corrado, 1.9 liter TDI models; and Audi 4-cyl. diesel models.

COMPARABLE: #V159



#T40011
3-Piece Locking Pin Set

Used to lock the timing belt tensioner while relieving pressure from the belt. Applicable: VW/Audi 3.0L V6 (5v), some 1.8L 4-cyl. (5v) turbo and 4.2L V8 (5v) with timing belt.

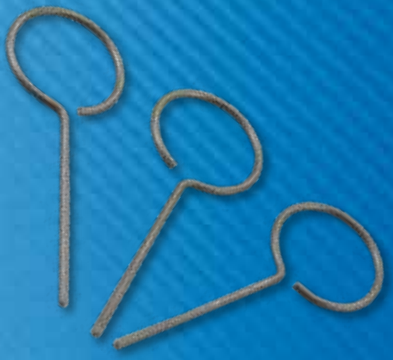

#3242
Crankshaft Locking Pin



Used to lock the crankshaft at TDC position in the VW/Audi engines: 2.7L V6 (APB), 2.8L V6 (except VR6) (AAH, AFC), 2.8L (AHA, ATQ), 4.0L W8 (BDP), 4.2L V8 (BAR, BNS, BVJ, BYH, CAUA), 4.2L V8 (AKB, AUX, AYS, AXQ, BAS, BFM, BGK, BHF, BNK), 5.2L V10 (BSM, BXA) and 6.0L W12 (BAP, BHT, BRP, BSB).



#T40069
Crankshaft Locking Pin



Locking pin to lock crankshaft at TDC in VW/Audi engines 2.5L (BGP, BGQ, BPR, BPS, CBTA and CBUA), 3.0L Supercharged (CGXB, CTUA, CJWB, CJWC, CJWE, CTWA and CTWB) and 3.2L (BKH and CALA). Applicable: Audi A4 [2005–2009], A5 [2008–2009], A6 [2009–2013], A7 [2012–2015], Q5 [2009–2017], Q7 [2011–2015]; VW Jetta [2005–2012] and Rabbit [2006–2009].



#T10115
Tensioner Locking Pins

Used to hold the timing belt tensioner in place while removing and installing the timing belt on VW Golf, Jetta and Beetle with 1.9L TDI Pumpe-Duse (BEW) and 2.0L turbo (BPY) engine [2004–newer].



#T40026
Crankshaft Locking Pin



Used to lock the crankshaft at TDC position when replacing the timing belt on Audi 3.0L [2002–2005]. Used in conjunction with #T40011, #T40028, #T40030. See #T4306 for complete set.



#T10368
Crankshaft Thrust Piece



Used when removing and installing lower timing chain cover on VW/ Audi 2.0L (4v) turbo with chain (CAEB) in A3 [2008–2009], A4 [2009–2010], EOS [2009], GTI [2008–2009], Jetta, Tiguan [2009–2015] and TT [2009].



#T40009
Tensioner Spanner Wrench

Used when adjusting the toothed belt tensioner eccentric to the proper pre-tension torque on VW/Audi V8 5v per cylinder.



- 1/4" Drive

#3299A
Tensioner Release Tool



Used for R & R of Serpentine belt. Applicable to Audi models with 3.0L V6 engines: Audi A4, A6 [2002–2005].



#7200
Camshaft Pulley Holder



Fits VW/Audi 1.8L, 2.0L turbo, 2.0L (BBW), 2.5L and 3.2L. Comes with 3 sets of interchangeable pins. Pins may be threaded in two different locations, based on application access. Overall length 18". 12" spread between pins at tip of arms, when pivot arm is at 90 degrees. Holding pins are made in USA.

COMPARABLE: #T10172

#T10050
Crankshaft Stop

Used for locking the crankshaft in place during timing belt replacement on VW TDI Pumpe-Duse engines [2004–2014] (BEW, BHW, BRM, CBEA, CJAA and CKRA) equipped with round pulley #038105263F and #045105263A. On the VW Jetta 1.9L BRM engine [2005–2006], it may need the #T10100 crankshaft stop instead if equipped with oval pulley number #038105263H. Also used on newer VW 2.0L TDI (BHW, CBEA and CJAA).



#T10252
Camshaft Locking Tool



Camshaft locking tool for VW/Audi 2.0L turbo engines (BPG, BPY and BWT). Applicable to Audi A3 [2006–2008], A4 [2005–2008], TT [2008–2009]; VW EOS [2007–2008], GTI and Jetta [2006–2008].

- Used in conjunction with #VW5220, #T10115 and #VW87-2.

#T10100
Crankshaft Stop

Used to lock the crankshaft in place during timing belt replacement. (*TDC marking at 1 o'clock). Applicable: VW Jetta 1.9L BRM with oval pulley part #038105263H [2005–2007].



#T10052
Cam Sprocket Puller



Used to remove camshaft sprocket from taper on camshaft. Applicable: VW 1.9L TDI-PD (BEW) (BRM) and 2.0L 4v TDI (CBEA).



#VW10352
Assembly Tool



Used for R & R of 4/3 way central valve for camshaft adjustment. Applicable to 2.0L 4-cyl. 4v turbo TFSI (CAEB) engine.

- 3/8" Drive
- COMPARABLE: #T10352 AND #T10352-1



#T40028
Camshaft Adjusting Socket

Used to adjust variable valve timing on the exhaust side camshaft to basic position. Applicable to 3.0L V6 in A4 [2002-2005] and A6 [2002-2004].

- 3/8" Drive

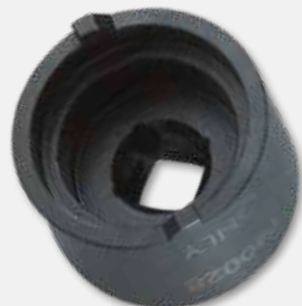

#T 40028 SHOWN HERE IN USE. RATCHET NOT INCLUDED

#VW4006
Puller Set



Puller used to remove cam sprockets. Applicable: VW 4-cyl. TDI, VW/Audi V6 5v and Audi V8 40v. Also includes both arms for 2.0L turbo direct injection engines (BPY, BPG and BWT). Includes: 18mm, 23mm and 25mm pulling arms.

COMPARABLE: #T40001, #T40001-6 AND #T40001-7



#T40058
Crankshaft Socket

For turning the crankshaft. Applicable: VW/Audi engines 3.2L V6 (BKH and CALA), 4.2L V8 (BAR, BNS, BVJ and CAUA), 4.2L V8 (BNK) and 5.2L V10 (BSM and BXA). Applicable: Audi A4, A6 [2005-2009]; A8, Q7, S6, S8 [2007-2009] and S5 [2008-2009].



#VW5220
Camshaft Adjuster Socket

Used for camshaft adjuster bolt on VW/Audi 2.0L turbo (BPG & BPY) engines.

- #10 Polydrive
- 1/2" Drive
- 53mm Length

COMPARABLE: #T40080



#T40001-6
Puller Claw

Used to remove camshaft gear/wheel on VW/Audi 2.0L (BPY, BPG and BWT) engines. Used in conjunction with #T40001 and #T40001-7. Included with #VW4006 set.



#T40001-7
Puller Claw

Used to remove camshaft gear/wheel on VW/Audi 2.0L (BPY, BPG and BWT) engines. Used in conjunction with #T40001 and #T40001-6. Included with #VW4006 set.



#T10531
Vibration Damper Assembly Tool

Used to dismantle & assemble the vibration damper on 1.8L and 2.0L 4v TFSI Direct Injection Engines. Applicable to VW/ Audi A4 [2010-2015], A5 [2010-2015], Beetle [2014-2015], CC [2014-2015], EOS [2012-2015], GTI [2014-2015], Passat [2014-2015], Tiguan [2012-2015] and TT [2010-2015].



#T10355
Crank Counter Hold Tool

For counter-holding the vibration damper when loosening or tightening the center bolt of the crankshaft in VW/ Audi 2.0L turbo TFSI (CAEB, CBFA and CCTA) engines [2009–newer].



#T10068A
Camshaft Alignment Fixtures

Used in VW/Audi 2.8L VR6 4v (AXK and BDF), 3.2L VR6 4v (BAA, BJS, BMX, BUB and CBRA), 3.6L VR6 4v (BHK, BHL and BLV) and 6.0L V12 (BAP, BRP and BSB). Applicable to Audi A3 [2006 - 2009], A8 [2005 - 2009], A8L [2005 - 2009], Q7 [2007 - 2009], TT [2004 - 2009]; Porsche Cayenne 3.6L [2008 - 2016]; Volkswagen CC [2009 - 2009], EOS [2007 - 2009], Eurovan [2001 - 2003], Golf [2004 - 2004], GTI [2002 - 2006], Phaeton [2004 - 2006], R32 [2004 - 2008] and Touareg [2004 - 2009].



#T40271
Camshaft Clamp

Used to lock camshaft sprockets in TDC position when installing timing chain on 2.0L turbo TFSI (CAEB) engines [2009– newer]. Essential for Generation III, very helpful for Generation I and II.



#3391
Camshaft Alignment Tool



Used to align both camshafts in VW/Audi V6 2.8L and 2.7L 5v engines (APB, AHA, ATQ and BEL) in Audi A4, A4 Avant [1998–2001], A6 [1998– 2004], A6 Avant [1999– 2001], Allroad Quattro [2001-2005], S4 [2000– 2002], S4 Avant [2001– 2002]. Used in conjunction with #3242.

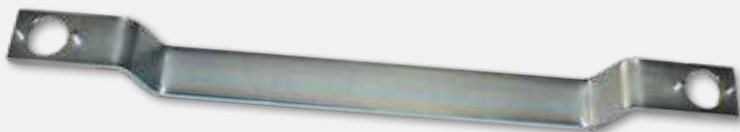

#T40196
Drift for Camshaft Slide Pieces



Used to set basic setting of cam slide adjuster on camshaft on 2.0L 4v (CAEB) turbo engines in Audi A4 [2008–2013] and Q5 [2009–2013].



**#ATF103
ATF Adapter**



For filling the VW Touareg transmission. Used in conjunction with ATF Filler System. Does not include pump, container, hose, or shut-off valve.

COMPARABLE: #VAG1924/1

**#ATF104
ATF Adapter**



Long, angled VW/Audi adapter Used in conjunction with ATF Filler System.. Does not include pump, container, hose, or shut-off valve.

COMPARABLE: #VAG1924

**#ATF105
ATF Adapter**



Used on VW/Audi transmissions. Used in conjunction with ATF Filler System.

- M10 x 1.0 Thread

COMPARABLE: #VAS6262/2

**#ATF16DSG
“DSG” ATF Adapter**

VW/Audi DSG driveline adapter used with the ATF Filler System.

- M24 x 1.5 Thread

COMPARABLE: #VAS6262A



**#ATFVW5
5-Piece Driveline Filler**

Used for filling fluids in transmission, differentials and transfer cases (not suitable for use with fuels or solvents). Container made of UHDP (ultra high density polyethylene). Individual manufacturer sets are available as well as the individual adapters. Newly designed drum features a second port for filling or dumping fluids without having to remove the pump—saving both time and clean up afterwards. Applicable to Audi, Porsche and Volkswagen models [1999-2018]



ATF CONTAINER IS MADE IN USA



- includes #ATF17CVT, #ATF16DSG, #ATF104, #ATF105, AND #ATF103

**#ATF17CVT
“CVT” ATF Adapter**

VW/Audi CVT driveline adapter used with the ATF Filler System.

- M22 x 1.5 Thread

COMPARABLE: #VAS5162



**#T10066
Haldex Filter Wrench**



Used for R & R the oil filter of the Haldex clutch on Audi TT and Volkswagen R32. (02C and 02M transmissions).

TO SEE OUR COMPLETE LINE OF DRIVELINE FILLERS AND ADAPTERS, SEE PAGES 84-87.

#VW133SI
Injector/Chamber Tool Set



Used to remove and install high pressure injectors and combustion chamber seal in VW/Audi models with 1.8L, 2.0L turbo, 3.2L V6 4v and 4.2L V8 4v. Applicable to Audi A3 [2006–2016], A4 [2005–2015], A5 [2008–2015], A6 [2005–2015], A7 [2012–2015], A8 [2007–2015], Q5 [2010–2017], Q7 [2007–2015], RS4 [2007–2008], S4 [2005–2015], S5 [2008–2015], S6 [2007–2015], S8 [2007–2015] and TT [2008–2015]; VW Beetle [2012–2015], CC [2009–2015], EOS [2007–2016], Golf [2006–2016], GTI [2006–2017], Jetta [2005–2016], Passat [2008–2015], Tiguan [2009–2015] and Touareg [2007–2015].

COMPARABLE: #T10133



#3307
Fuel Pump Wrench

For R & R of the fuel pump on various VW/Audi models: Audi A4 [2002–2004], A6 [1999–2004].

California Residents: Proposition 65 WARNING. See page 125 for info.



SHOWN
HERE WITH
MERCEDES
FUEL LINE

#MW2050F
Fuel Line Pliers

Used for fuel lines with plastic snap-together connectors found on VW Golf [1999–2005].



SHOWN
HERE WITH
AUDI FUEL
FILTER



#3217
Fuel Sender Spanner

Used to remove and install the fuel gauge sending unit. Applicable to Porsche Boxster (986) [1997–2004] and 911 Carrera, Turbo, GT2 and GT3 (996) [1999–2005]; VW Passat (FWD) [1998–2005].

- 1/2" Drive
- 139mm

California Residents: Proposition 65 WARNING. See page 125 for info.



#FZ163
Cooling System Adapter



For pressurizing cooling system. Applicable to Porsche Cayman [2005–2013] and Boxster [2007–2012].



#T40149
A/C Coupler Release Tools

NEW!

Used to disconnect the A/C coupler on Audi A4, A5 and Q5 [2007-Newer].



#TA18
Adapter



For brake master cyl. or clutch master cyl. reservoirs. Used in conj. with pressure bleeder. (1/4-18 NPT). Fits most European cars.

- M46 x 3.5 Threads
- 1/4-18 NPT Air fitting not included



#FZ22
Tank Adapter



For pressurizing cooling system. Fits VW/Audi [1978–1993] models with male threads on filler neck of expansion tank. Applicable: Audi A8 and S8.

- M48 X 3 Threads



#FZ41
Tank Adapter



For pressurizing cooling system on VW/Audi models (except older A8 and S8) [1999–2018]; Porsche 911 (991 body) [2012–2015] and Cayenne [2004–2013].

- M63 X 3 Threads



#OFVW2013
Oil Funnel



VW/Audi engine oil funnel for 1.8L, 2.0L Turbo and 2.0L diesel engines. Applicable to Audi A3 TDI [2015-Newer], Q3, S3 [2016-Newer]; VW Beetle, Convertible, EOS, Golf, Jetta, Jetta Sportwagon, Passat and Tiguan [2014-2018].



#T40057
Oil Filter Housing Drain

For draining the oil filter housing on VW/Audi with 2.0L turbo (BPG, BPY & BWT) [2006– 2008] and 2.5L inline 5- cyl. engine [2005– 2014]. Prevents spillage during oil filter change and allows for drainage of oil from the filter housing.



#OFAUD1000
Euro 1/4 turn Oil Funnel



No more mess, attaches directly to the valve cover and seals just like the factory cap. Fits VW/Audi 1.4L turbo, 1.8L turbo, 1.9L TDI, 2.0L turbo, 2.8L 5v, 3.0L 5v, 3.2L, 3.6L and 4.2L 5v and Tiguan 2.0L [2016]. For newer TDI and 2.0 turbo engine [2014– 2018], see funnel #OFVW2013.



#VW10549
Drain Plug Tool



Used to remove and install the oil drain plug on VW/ Audi with 1.8L and 2.0L Turbo engines [2015– 2019]. Applicable engines: CPKA, CPRA, CPPA, CBFA, CCTA, CBEA, CNTA, CXCA, CXBB, CXBA, CPKA, CNSB and CNSA.



#AU40178
Engine Oil Dipstick



Applicable to Audi A4 [2009-2017], A5 [2009- 2015], A6 [2009-2015], A8 [2011-2014], Q5 [2013-2015], RS5 [2013-2015], S4 [2010-2015], S5 [2009-2012], S6 [2013-2015], S7 [2013-2015]; Porsche Cayenne S Hybrid [2011-2014], Panamera S Hybrid [2012-2014]; Volkswagen Touareg [2011-2014].

COMPARABLE: #T40178



#FUN14EURO
FUN14KIT
Euro Adapter



For use with our #FUN14KIT. Specifically designed to attach to the valve covers. When you're adding oil to the engine you don't have to worry about making a big mess due to the internal baffle of the valve cover. *May not fit applications where cowl causes interference. Fits VW/Audi 1.4L turbo, 1.8L turbo, 1.9L TDI, 2.0 turbo, 2.8L (30v), 3.0L (30v), 3.2L, 3.6L and 4.2L (40v).



#M0219
Oil Filter Wrench



Applicable to Audi A4 [2009–2016], Q5 [2012–2016] 2.0L Turbo engines; VW CC, EOS, Tiguan [2009–2013], Golf [1999–2005], GTI [2008], Jetta [2005–2013], Jetta 1.4T [2016], Beetle 2.5L [2005–2014]; Porsche 911 [1999–2008], Boxster [1997–2008] and Caymen [2005–2008].

- 74mm - 14 Flats
- Use with 22mm socket



California Residents: Proposition 65
WARNING. See page 125 for info.



#2101
7-Piece Oil Filter
Wrench Socket Set



Includes oil filter wrench sockets for many domestic and foreign applications. The 2132, 2136, 2175 and M0219 cover VW/Audi engines.



California Residents: Proposition 65
WARNING. See page 125 for info.

#2175
Oil Filter
Wrench



Applicable to Golf, Jetta and Rabbit with 2.5L engines.

- 74.5mm - 14 Flats
- Use with 22mm socket

California Residents: Proposition 65
WARNING. See page 125 for info.



#2132
Oil Filter
Socket

Applicable to Audi Q3 & S3 2.0L Turbo, [2015–2016] and VW Golf and Jetta 2.0L TDI [2011–2016].

- 32mm - 6 Flats
- 3/8" Drive
- #23236 Double-sided Socket may be purchased instead, and adds more coverage



#2136
Oil Filter
Socket

Applicable to Audi Q7 3.6L, A6 3.0 L SC [2014– 2016], Q7 3.0L SC [2011–2016]; VW Corrado VR6 [1993], Eurovan VR6 and Golf R32 3.2L VR6 [2004], Jetta 2.0L turbo [2006]; Jetta 2.8L VR6, Passat 2.8L VR6, Touareg Porsche 911, Boxster, Cayenne and Panamera [2009–2016].

- 36mm - 6 Flats
- 3/8" Drive
- #23236 Double-sided Socket may be purchased instead, and adds more coverage





#23236
32 x 36mm Oil Filter Socket

Double sided 3/8" drive. Applicable to Audi Q3 and S3 2.0L Turbo [2015–2016], A6 3.0L [2014–2016], Q7 3.0L [2011–2016], Q7 3.6L [2007–2010]; Volkswagen TDI [2011–2016], Touareg [2009–2016] and VR6 motors.



DOUBLE-SIDED

#T10107B
Long Allen Socket

Fits right hand stub shaft on 6-speed manual, OA5 and O2N. Also applicable to VW 2.5L I5 (4v) intake manifold bolts, Jetta (BGP & BGQ) [2005–2007], Jetta (CBTA & CBUA) [2008–2014], Rabbit (BGP & BGQ) [2006–2007], Rabbit (CBTA & CBUA) [2008–2009], Beetle (BPR & BPS) [2006–2010] and Beetle (CBTA & CBUA) [2012–2014].

- 6mm
- 3/8" Drive
- 325mm Length

COMPARABLE: #T10107A



#3462
Head Bolt Socket



Applicable to most VW/Audi engines [1998–newer].

- #10 Polydrive
- 1/2" Drive
- 155mm Length

COMPARABLE: #3452, #3452A AND #T10070

#ALT34018
Alternator Pulley Socket

NEW!

For R & R of the free-wheel pulley on the alternator. Used in conjunction with #S3054X-10 or the #S1054TXT-50 sockets.

COMPARABLE: #3400



#6355X-14
12-Point Socket

Ideal for use on rear brake caliper bolts on VW Jetta and Passat [2006– newer].

- 14mm
- 1/2" Drive
- 64mm Length



#H2223LGT-30
Torx Socket Insert



Used for the R & R of the airbag from the steering wheel. Applicable to many VW models [1994–2002].

- T-30
- 70mm length



#S3054X-10
Head Bolt Socket



Used on VW/Audi head bolts that are 10mm, 12-pt. Most [1998–later] VW/Audi applications require the #3462 head bolt socket.

- 10mm
- 1/2" Drive
- 140mm Length

COMPARABLE: #3410



#3424
Spreader



For the R & R of the front shock absorber tube from the wheel bearing housing on Audi A3 [2006–2008], TT [2000–2008] and A5 [2008–2009]; Volkswagen Golf, Beetle [1999–2008], Rabbit, GTI, Passat [2006–2008], Jetta [1999–2006], Tiguan [2008].

- 3/8" Drive



#6300
12-point Socket Bit Set



7-Piece set includes sockets:

- #6300XL-14 (long 14mm)
- #6300XL-8 (long 8mm)
- #6300XL-10 (long 10mm)
- #6300X-16 (16mm tamper-proof)
- #6300X-12 (12mm bit)
- #6300X-14 (14mm bit)
- #3424 (Spreader)

#6300X-12
12mm, 12-Point Socket Bit

For the R & R of axle shaft bolts on newer VW Jetta and rear toe adjustment on Audi A6 [1999–newer]. Used for bell housing bolts with tight clearance on various VW models.



#6300X-14
14mm, 12-Point Socket Bit

For R & R of Audi TT differential bracket and for bell housing bolts with tight clearance on various VW models.



#6300X-16
12-Point Socket

Used for R & R of manual transmission drain plug. Applicable to Audi Q7, Porsche Cayenne and VW Touareg brake caliper bolts.

- 16mm Tamper-proof
- 1/2" Drive
- 60mm Length

COMPARABLE: #3357



#6300XL-8
12-Point Long Socket

Used for R & R of axle shaft bolts on VW Beetle, Jetta TDI and older VW/Audi models.

- 8mm
- 3/8" Drive
- 90mm Length



#6300XL-10
12-Point Long Socket

Used for R & R of axle shaft bolts on VW Passat and Golf.

- 10mm
- 3/8" Drive
- 90mm Length

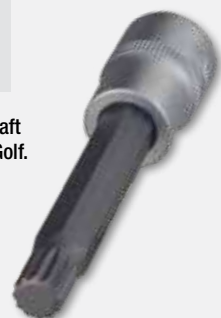

#6300XL-14
12-Point Long Socket

Used for R & R of late model VW Eurovan axle shafts and ball joints. Also used on VW Touareg inner CV bolts.

- 14mm
- 1/2" Drive
- 140mm Length

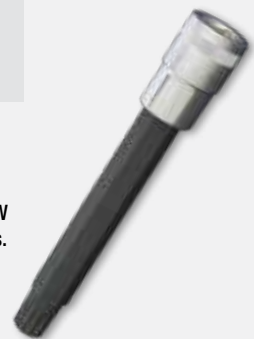

**#6506
Axle Nut Set**

Axle nut socket set covers all VW/Audi vehicles from [1996–2015] with a 14mm and 17mm allen as well as an 18mm, 24mm, 30mm, and 32mm 12-pt. socket. Applicable: Audi A4 [2002–2009], A4 [1996–2001], A6 [1999–2009]; VW Beetle, Cabrio, Golf, Jetta [1999–2015], Tiguan (4Motion) and Touareg [2009–2015].

- For [2009–newer] Audi A4 rear axle bolts, purchase #H985-19

**#6500X-30
12-Point Socket**

Used For R & R of front axle nuts. Applicable: [1999–2005] VW Cabrio, Beetle, Golf and Jetta.

- 30mm
- 1/2" Drive
- 45mm Length

**#6500X-32
12-Point Socket**

Used for R & R of front and rear axle nuts on [2004–2016] VW Touareg.

- 32mm
- 3/4" Drive
- 60mm Length

**#6500X-18
12-Point Socket**

Used for the R & R of the rear axle bolts on VW Jetta and Golf [2006–2015].

- 18mm
- 1/2" Drive
- 95mm Length

COMPARABLE: #T10162

**#6500-14
Allen Socket**

Applicable to Audi A4 Quattro front and rear axle bolts [1996–2001] and VW Passat rear axle bolts [1996–2002].

- 14mm
- 1/2" Drive
- 37mm Length

**#6500-17
Allen Socket**

Applicable to Audi A4 (AWD) front & rear axle bolts [2002–2009], Audi A6 front axle bolts [1999–2009] and VW Passat front axle bolts [1998–2005].

- 17mm
- 1/2" Drive
- 38mm Length

**#3200X-4
4mm, 12-Point
Screwdriver Bit**

1/4" hex drive bit used for R & R of 4mm door handle screws. Applicable: VW Golf, Jetta, Passat and Beetle.

**#6500X-24
12-Point Socket**

Used for R & R of front axle bolt. Applicable: VW Golf [2010–2013] and Tiguan [2009–2015].

- 24mm
- 1/2" Drive
- 38mm Length

COMPARABLE: #T10361

**#3200T-6
T-6 Torx Bit**

Used for the R & R of door hinge fasteners on VW Touareg as well as Porsche Cayenne.

**#3200X-8
8mm, 12-Point Bit**

Used for R & R of door hinge fasteners on late model VW using 8mm, 12-point bolts.



TOOLS FOR
HEAVY TRUCK

73-77

CUMMINS /
DETROIT DIESEL /
FREIGHTLINER /
INTERNATIONAL /
MACK / VOLVO

73-77





#CM3021
Cummins ISX 4 Wedge
Timing Set

NEW!



Used for setting the geartrain timing on all Cummins ISX engines [2007-2016].

COMPARABLE: #3163021

- Set includes 4°, 6° (x2) and 7° Wedges and crank pin.
- Extra 6° wedge is included for [2007-2012] engines with two camshafts.
- Comes in custom plastic storage case.



#CM369
Cummins ISX
Gear Puller

NEW!

Used to pull the Injector and Valve cam gears on Cummins engines [2007-2016].

COMPARABLE: #3163069



#VTC100
Coolant Drain Hose

NEW!

Used to drain the radiator on Volvo Heavy Duty Trucks. Applicable to Volvo Heavy Duty Trucks [2004-2018] and Mack Trucks [2007-2018].

COMPARABLE: #9996049





#HTLP100
Universal Heavy Truck Diesel Engine Cylinder Wet Liner Puller

NEW!



Used to remove the diesel cylinder wet liner from heavy trucks and heavy equipment for Caterpillar, Cummins, Detroit Diesel, Mercedes OM460 and Volvo D13 engines.

- Includes thinner blades for Detroit Diesel

NOTE: SHORTER CYLINDER LINERS MAY REQUIRE ADDITIONAL SPACING BLOCKS UNDER THE VERTICAL SUPPORTS TO INCREASE THE LENGTH OF PULL.



#MO284 Oil Filter Wrench



Applicable to Dodge & Mercedes Sprinter with 3.0L V6 CRD engine [2007–2015].

- 84mm - 14 Flats
- Use with 22mm socket



California Residents: Proposition 65 WARNING. See page 125 for info.

#2175 Oil Filter Socket



Applicable to Mercedes Sprinter with 2.1L Turbo Diesel [2014–2017].

- 74.5mm - 14 Flats
- Use with 22mm socket



California Residents: Proposition 65 WARNING. See page 125 for info.

#M1020 Glow Plug Socket

Applicable to Dodge / Mercedes Sprinter.

- 10mm
- 3/8" Drive



#OFAUD1000 Euro 1/4 Turn Oil Filler



Specifically designed to attach to the valve covers. When adding oil to the engine you don't have to worry about making a mess due to the internal baffle of the valve cover. Applicable: Dodge, Freightliner & Mercedes Sprinter Vans [2006–2013] 2.7L and 3.0L V6 CRD.



#M820 Glow Plug Socket

Applicable to Dodge / Mercedes and Sprinter.

- 8mm
- 3/8" Drive



#ATFBASIC Basic Driveline Filler

Used for filling fluids in transmission, differentials and transfer cases (not suitable for use with fuels or solvents). Individual manufacturer sets are available as well as the individual adapters. U.S. made container, made of UHDP (ultra high density polyethylene). Newly designed drum features a second port for filling or dumping fluids without having to remove the pump—saving both time and clean up afterwards.

- Used only to Fill, Not to Drain—So Clean Fluid Stays Clean
- 8 Liter Capacity
- Quick Attachment Adapters
- Pump Dispenses Efficiently
- On/Off Ball Valve
- Hose Length: 4ft 10in



ATF CONTAINER IS MADE IN USA

#2017SACP Swivel Spring Clamp Pliers

NEW!



Used for various different spring clamp sizes found on fuel lines, radiator hoses, transmission cooler lines, etc. The rotating heads with unique grooves allow for 360° of adjustability for those hard to reach angles and locations.



#FZ55
Tank Adapter



Cooling system pressure tester adapter. Applicable to Dodge / Freightliner / Mercedes Sprinter vans [2007–2019].

- M46 x 2.5 Threads



#SPR886
Transmission Dipstick

Dodge / Freightliner Sprinter transmission dipstick [2002-2009].

COMPARABLE: #8863B



#6300X-16
12-Point Tamper-Proof Socket

Used for Mercedes diesel truck flywheel bolts. Also available in our #6300 set.

- 16mm Tamper-proof
- 1/2" Drive
- 60mm Length

COMPARABLE: #904589001000



#FZ32A
Tank Adapter



For pressurizing cooling system. Applicable to Freightliner Cascadia [2008], Columbia [2008]; International 6.4L Diesel [2012], Navistar VT 365 and International with 466 engine [1994–2002].

- M52 x 2.5 Threads



#H2850-E24
Female Torx Socket



Used for R & R of head bolts on International and Man commercial vehicles which use MAN D20, D25 and D28 engines.

- E24
- 3/4" Drive
- 110mm Length



#SPR0558
Glow Plug Pliers



For disconnecting the electrical connector that is attached to the glow plug used on Dodge Sprinter.

#FZ35A
Tank Adapter



For pressurizing cooling system. Applicable to Freightliner diesel trucks [2004] and Sterling trucks [2005].

- M52 x 2.5 Threads



#FZ22
Tank Adapter



For pressurizing cooling system. Applicable to Volvo trucks V670 and VN430; Kenworth trucks [2007–2008].

- M48 x 3 Threads



#FZ36
Cap Adapter



For testing pressure relief valve in cap. Applicable to Freightliner diesel trucks [2004] and Sterling trucks [2005].

- M52 x 2.5 Threads



#FZ25
Tank Adapter



For pressurizing cooling system. Applicable to Volvo trucks [1978-2006] and Dodge Promaster 1500 [2014–2018].

- M47 x 3 Threads



#6500T-100
Torx Socket

Used to remove parts to allow access for brake jobs on MAN Commercial Buses.

- T-100
- 3/4" Drive
- 60mm Length





**ASSENMACHER[®]
SPECIALTY TOOLS**

Are you tired of hearing this when you call other companies?

“Our offices are located at...”

(Like you called to find out where they are!)

“Thank you for calling, if you know your party's extension...”

(Yea, right, I have my party's extension saved on a napkin from yesterday!)

“All of our agents are currently assisting other customers...”

(Does this mean I will wait 10 minutes, for a call center off shore to answer?)

“If you know the first or last name of the person you wish to speak to...”

(I see 150 customers on my tool route every week, and don't have time for this!)

At AST there are real people answering our phones!





TOOLS LISTED BY **SPECIALTY AND APPLICATION**

PLIERS	80
GENERAL TOOLS	81-83
FLUID EXCHANGE	84-87
FUNNELS	88-91
OIL FILTER SOCKETS & WRENCHES	92-94
DIPSTICKS / OIL & TRANSMISSION	95
SPECIALTY SOCKETS	96-101
STUD PULLERS	102-103
BODY / RADIO / ELECTRICAL	104-105
MOTORCYCLE / ATV / MARINE	106
ELECTRIC / HYBRID VEHICLES	107-108
APPLICATION CHARTS	108-124
CALIFORNIA PROP 65 WARNINGS	125

#2017SACP
Swivel Spring Clamp Pliers

NEW!

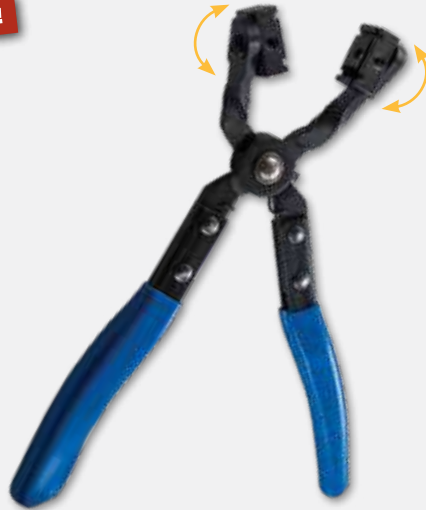

Used for various different spring clamp sizes found on fuel lines, radiator hoses, transmission cooler lines, etc. The rotating heads with unique grooves allow for 360° of adjustability for those hard to reach angles and locations.

#CP2015
Fuel Hose Clamp Pliers

Used to crimp fuel hose clamps.



#M2010ACP
Angled Fuel/EVAP Clamp Pliers

Used for the unlocking and locking of Fuel/EVAP hose CLIC R® clamps on newer vehicles.



#SCP2014
Spring Clamp Pliers

Pliers used for spring clamps found on fuel lines, radiator hoses, Honda transmission cooler lines, etc. Unique Grooves in Pliers Allow Grabbing Clamps from 2 Angles. The Overall Length is 8".



#MVW2050F
Fuel Line Pliers

Fuel line pliers used for fuel lines with plastic snap-together connectors found on Volkswagen and Audi models and Mercedes (163) M-Class fuel filters and applicable to some Fiat, GM and Opel gas engine vehicles. Also works on late model Lexus and Toyota fuel/evap lines.



#M2000CP
Fuel / EVAP Clamp Pliers

Used for the unlocking and locking of Fuel/EVAP hose CLIC R® clamps on newer vehicles.



#SPR0558
Glow Plug Pliers

For disconnecting the electrical connector that is attached to the glow plug used on Dodge Sprinter.



#WSC15
Wire Soldering Clamp



An ideal solution for holding wires in place during soldering. It is a second set of hands, clamping down onto wires from either side of the tool. Holds firmly and may be used for various gauges of wiring.

 California Residents: Proposition 65
WARNING. See page 125 for info.



- Six inch flex cable for difficult to reach areas
- Spring-loaded, sliding claws clamp onto wires firmly
- Extra strong magnetic base provides ample support
- Frame and Claws Made in USA from Diecast Aluminum



#WSFLCPLUS
Flashlight Clamp with Magnetic Base and Flexible Cable



Best for round medium to small flashlights that are .30lbs and lighter.



FLASHLIGHT NOT INCLUDED.



#WSFLC
Clamp



Clamp used in conjunction with our #WSC15 Soldering Clamp Tool. This can be used to help mount your #WSC15 to "Non-Magnetic" surfaces while you are soldering or it can be used as a flashlight holder, giving you that extra set of hands.

NOTE: BEST FOR ROUND MEDIUM TO SMALL FLASHLIGHTS THAT ARE .30LBS AND LIGHTER.





#3206
Door, Trim and Molding Tool Set

Set includes a T-25 long Torx screwdriver Shank Length 10 inches for accessing door handles on various Mercedes models. One trim spoon and one light duty hook is included for various interior jobs. Includes one pair of trim and cluster hooks. Three soft wedges are also included for various trim and molding jobs both for interior and exterior applications. Includes carrying pouch.



#MW35
Hard Black Wedge Set



Constructed of strong black polycarbonate, this set of three wedge-style dash panel removal tools allows installers to remove oil pans, rocker covers and more, without causing damage.

- More Ridgid than the orange #MW 34 set and used on much heavier jobs

California Residents: Proposition 65 WARNING. See page 125 for info.

#3810
6-Piece File Set

Includes the following six files and a protective case: flat file, flat file/tapered front, round file, triangle file, square file and a half round / half flat file. Steel construction with rubber / plastic handles. Total length is 7.25" (including handle).



#MW34
Soft Orange Wedge Set



Constructed of soft orange polyethylene, this set of three wedge-style dash panel removal tools allows installers to remove dash trim bezels and other vehicle interior moldings including door panels, without causing damage. Great for installing electronics.

- Three diverse sizes for various uses



#ALSJ05
Aluminum Soft Jaw Vise Blocks

Pair of 5" soft jaws machined from aluminum. V-slots put a better grip on round objects. Each jaw has a small and large vertical slot. A large horizontal slot runs the length of each jaw. Strong magnets attach soft jaws firmly to 4", 5" and 6" vises. Applicable to many makes and models.



#3900
5-Lobe Tamperproof Bit Set

5 Lobe bits and a 1/4" drive. Includes: T-10, T-15, T-20, T-25, T-27, T-30, T-40, T-45 and T-50. Applicable to various BMW, Mercedes, VW and Volvo models.



#ATFBASIC
Basic Driveline Filler

Used for filling fluids in transmission, differentials and transfer cases (not suitable for use with fuels or solvents). Individual manufacturer sets are available as well as the individual adapters. U.S. made container, made of UHDP (ultra high density polyethylene). Newly designed drum features a second port for filling or dumping fluids without having to remove the pump—saving both time and clean up afterwards.

ATF CONTAINER IS
MADE IN USA



#EU2009
Brake Bleeder Wrench

9mm brake bleeder wrench.



#EU2011
Brake Bleeder Wrench

11mm brake bleeder wrench.



#7200
Camshaft Pulley Holder



Applicable to Toyota, VW/Audi and Volvo. Comes with 3 sets of interchangeable pins. Pins may be threaded in two different locations, based on application access. Overall length 18". 12" spread between pins at tip of arms, when pivot arm is at 90 degrees. Holding pins are made in USA.



#ATFSET15

15-Piece Driveline Filler System

Contains all AST adapters produced through 2018. Used for filling fluids in transmission, differentials and transfer cases (not suitable for use with fuels or solvents). Individual manufacturer sets are available as well as the individual adapters. U.S. made 8L container, made of UHDP (ultra high density polyethylene). Newly designed drum features a second port for filling or dumping fluids without having to remove the pump—saving both time and clean up afterwards. Applicable: Audi, BMW, Ford, GM, Honda, Infiniti, Lexus, Mercedes, Mini, Nissan, Porsche, Subaru, Toyota, Volkswagen and Volvo.



ATF CONTAINER IS
MADE IN USA

#ATFSET9

9-Piece Driveline Filler System

Used for filling fluids in transmission, differentials and transfer cases (not suitable for use with fuels or solvents). Individual manufacturer sets are available as well as the individual adapters. U.S. made 8L container, made of UHDP (ultra high density polyethylene). Newly designed drum features a second port for filling or dumping fluids without having to remove the pump—saving both time and clean up afterwards. Applicable: Audi, BMW, Ford, Honda, Lexus, Mercedes, Porsche, Toyota, Volkswagen and Volvo.

- For 724 transmission, see #M21250.
- For 725 transmission, see #ATFMB725.



ATF CONTAINER IS
MADE IN USA

#ATFEURO8

8-Piece Euro Driveline Filler

For filling fluids in transmission, differentials and transfer cases (not suitable for use with fuels or solvents). Individual manufacturer sets are available as well as the individual adapters. U.S. made 8L container, made of UHDP (ultra high density polyethylene). Newly designed drum features a second port for filling or dumping fluids without having to remove the pump—saving both time and clean up afterwards. Audi, BMW, Mercedes, Mini, Porsche, Volkswagen and Volvo.



ATF CONTAINER IS
MADE IN USA

#ATFVW5

5-Piece Driveline Filler for VW/Audi

Used for filling fluids in transmission and transfer cases (not suitable for use with fuels or solvents). U.S. made 8L container, made of UHDP (ultra high density polyethylene). Individual manufacturer sets are available as well as the individual adapters. Newly designed drum features a second port for filling or dumping fluids without having to remove the pump—saving both time and clean up afterwards. Applicable TDI or 2.0L (turbo) gas models: [2002–2008] Audi A4 (AWD), [2005–2011] A6 (FWD) [V6]; [2007–2016] VW Eos, [2008–2016] Golf, R32, GTI, [2005.5–2016] Jetta, [2004–2016] Beetle, [2012–2015] Passat, [2009–2016] CC.

- Used only to Fill, Not to Drain—So Clean Fluid Stays Clean
- 8 Liter Capacity
- includes 5 Attachment Adapters
- Pump Dispenses Efficiently
- On/Off Ball Valve
- Hose Length: 4ft 10in



ATF CONTAINER IS
MADE IN USA

#ATFMB

Driveline Filler for Mercedes

For filling transmission fluid in Mercedes 722.9 automatic transmissions [2004-2018] using a M12 x 1.5 adapter (not suitable for use with fuels or solvents). Set includes pump, U.S. made 8L container, made of UHDP (ultra high density polyethylene), hose, shut-off valve and the #ATF 129 adapter. Additional adapters are available separately.

- For 724 transmission, see #M21250.
- For 725 transmission, see #ATFMB725.

- Used only to Fill, Not to Drain—So Clean Fluid Stays Clean
- 8 Liter Capacity
- Quick Attachment Adapters
- Pump Dispenses Efficiently
- On/Off Ball Valve
- Hose Length: 4ft 10in

INCLUDES #ATF 129 ADAPTER,
OTHERS AVAILABLE INDIVIDUALLY



ATF CONTAINER IS
MADE IN USA

#ATFFORD

Driveline Filler for Ford

Used for filling Ford automatic transmissions (not suitable for use with fuels or solvents). Set includes pump, U.S. made 8L container, made of UHDP (ultra high density polyethylene), hose, shut-off valve and the #ATF 101 adapter. Applicable: [2004–2010] Ford Explorer, [2005–2010] Mustang, [2002–2005] Thunderbird.

- Used only to Fill, Not to Drain—So Clean Fluid Stays Clean
- 8 Liter Capacity
- Quick Attachment Adapters
- Pump Dispenses Efficiently
- On/Off Ball Valve
- Hose Length: 4ft 10in

INCLUDES #ATF 101 ADAPTER,
OTHERS AVAILABLE INDIVIDUALLY



ATF CONTAINER IS
MADE IN USA



Shown here:
ATF VW 5 being used

#ATFBASIC
Basic Driveline Filler

Used for filling fluids in transmission, differentials and transfer cases (not suitable for use with fuels or solvents). Individual manufacturer sets are available as well as the individual adapters. U.S. made container, made of UHDP (ultra high density polyethylene). Newly designed drum features a second port for filling or dumping fluids without having to remove the pump—saving both time and clean up afterwards.

- Used only to Fill, Not to Drain—So Clean Fluid Stays Clean
- 8 Liter Capacity
- Quick Attachment Adapters
- Pump Dispenses Efficiently
- On/Off Ball Valve
- Hose Length: 4ft 10in

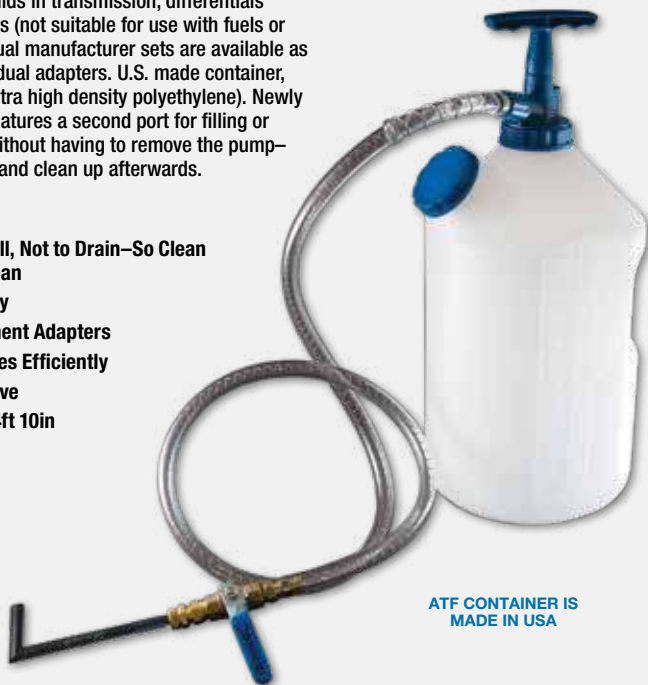

ATF CONTAINER IS
MADE IN USA

#ATFDRUMONLY
Additional ATF Drum



8 Liter Drum Only for Driveline Filler. Used to store additional fluids that are not in use.



#ATF101
ATF Adapter
for Ford



Adapter used in conjunction with the ATF Filler System for Ford Explorer [2004-2010], Mustang [2005-2010] and Thunderbird [2002-2005].

- 1/8-27 NPT

#ATF102
Universal ATF
Adapter



Long, angled adapter used in conjunction with the ATF Filler System. Used on many applications.

#ATF103
ATF Adapter
for VW/Audi



Used for filling the VW Touareg transmission.

COMPARABLE: #VAG1924/1

#ATF104
ATF Adapter
for VW/Audi



Long, angled adapter used in conjunction with ATF Filler Systems.

COMPARABLE:
ADAPTER INCLUDED WITH VW FACTORY #VAG1924

#ATF105
ATF Adapter for
VW/Audi and Mini



Transmission filling adapter used on VW/Audi and Mini with "AISIN" transmission.

- M10 x 1.0 Threads

COMPARABLE: #VAS6262/2

#ATF17CVT
ATF Adapter for
VW/Audi CVT



Driveline adapter for VW/Audi CVT transmission.

- M22 x 1.5 Threads

COMPARABLE: #VAS5162

#ATFSU118
Subaru Filling Adapter



Used for filling the front Differential on Subaru Crosstrek [2012-2017], Forester (non turbo) [2014-2017], Impreza (non turbo) [2012-2017], Legacy 4 cyl. [2013-2017] and Outback (4 cyl.) [2013-2017].

- M18 x 1.5 Threads

#ATF108V
ATF Adapter for Volvo



Driveline filler adapter. Applicable to some Volvo models [2007-2018] 6 speed and 8 speed Automatic transmissions with out a fluid dipstick. Used to fill with using the 5/16" x 24 threaded plug.

- 5/16-24 Threads

#ATFTOY118
ATF Adapter
for Toyota



Adapter for some Lexus models; 4Runner [2005-2010], FJ Cruiser [2007-2010], Sequoia [2005-2010], Tacoma [2005-2010] and Tundra [2005-2010].

- M18 x 1.5 Threads

COMPARABLE:
#00002-11103-02

#ATF16DSG
ATF Adapter for DSG



Driveline adapter for VW/Audi DSG transmission.

- M24 x 1.5 Threads

COMPARABLE: #VAS6262A

#ATF129
ATF Adapter
for Mercedes



Mercedes adapter for 722.9 transmissions [2004-2018].

- M12 x 1.5 Threads

• For 725 Transmissions, see #ATFMB725

#ATF180
ATF Adapter
for Infiniti



Adapter for Infiniti models with 7-speed automatic transmissions [2008-2017].

- M8 x 1.0 threads

#ATFSU100
Universal ATF Attachment

This flexible adapter is used to fit into hard to reach applications where there is at least a 10mm internal diameter opening to fit into.



#ATF175 GM
ATF Adapter
for GM



Adapter for 6L80/6L90 transmissions found in Cadillac models [2003-2014]; Chevy models [2006-2016]; GMC Yukon Denali [2007]; Hummer H2 [2008] and Pontiac G8 [2008].

- M12 x 1.75 Threads

COMPARABLE: #DT-47784



#ATF125NIS
ATF Adapter
for Nissan



Adapter used to fill the CVT transmission in Nissan Altima [2014-2016], Pathfinder [2013-2017], Rogue [2014-2017], Sentra [2017] and Versa [2013-2017].

- M12 x 1.25 Threads

COMPARABLE:
NISSAN #KV31103950



**#OFFM2012
Oil Funnel for
Ford and Mazda**



Used on newer Ford and Mazda models with 4 cylinder engines. Applicable to Ford EcoSport [2018], Edge [2012–2018], Escape [2008–2016], Expedition [2016–2018], Explorer [2012–2015], F-150 [2016–2018], Focus [2007–2018], Fusion [2013–2018], Mustang [2018]; Jaguar XF [2013–2015]; Land Rover LR2 [2015], Range Rover Evoque [2012–2015]; Mazda 3 [2006–2015], 5 [2005–2015], CX-5 [2013–2015], Mazdaspeed 3 [2007–2015], Mazdaspeed 6 [2005] and MX-5 Miata [2006–2015].

- **DO NOT USE BRAKE CLEAN**

NOTE: MAY NOT FIT SOME APPLICATIONS WHERE THE FIRE WALL COWL DOESN'T PROVIDE CLEARANCE FOR ATTACHMENT OF FUNNEL. USE #FUN14KIT FOR THESE APPLICATIONS.



**#OFSU1042
Subaru Oil Funnel**



Fits all Subaru models with threaded oil cap (except Tribeca). Applicable to Subaru BRZ, Impreza, Imreza WRX, Impreza WRX STI, Legacy, Outback and Scion FR-S [2000–2018].

- **DO NOT USE BRAKE CLEAN**



**#OFGMRD08
Ford and GM Oil Funnel**



Applicable to various Aston Martin, Buick, Cadillac, Chevrolet, Ford, GMC, Hyundai, Jaguar, Land Rover, Mazda, Mercury, Pontiac and Saab models.

- **DO NOT USE BRAKE CLEAN**



**All AST Funnels
are Made in USA**

**No Mess Fill
Every Time**

**Made of
Strong ABS Plastic
or Polycarbonate**

**DO NOT
USE BRAKE CLEAN!**

**Using Brake Parts
Cleaner on Plastic Voids
Warranty**

**#OFSU42
Subaru Adapter**



For use with our #FUN14KIT or #OFKIT. We left space in the #FUN14KIT to accommodate this adapter. Fits all Subaru models with threaded oil cap (except Tribeca). Applicable to Subaru BRZ, Impreza, Imreza WRX, Impreza WRX STI, Legacy, Outback and Scion FR-S.

- **DO NOT USE BRAKE CLEAN**

**#OFAAGM
Angled Funnel
Extension**



Extension for our #OFGMRD08 Funnel. Adds coverage and access where normal funnels will not fit. Applicable to Chevrolet Silverado [2013–2014]; Ford F-150 5.0L [2015], F-250 6.7L [2016]; GMC Sierra [2013–2014].

ONLY USED IN CONJUNCTION WITH #OFGMRD08 OR #OFGMFORD FUNNELS.

- **DO NOT USE BRAKE CLEAN**



WARNING:

These products can expose you to chemicals including Acrylonitrile & Styrene, which are known to the State of California to cause cancer and Bisphenol A (BpA) & Butadiene, which is known to the State of California to cause birth defects or other reproductive harm.

#OFCRY36
Chrysler Oil Funnel



Oil funnel for Chrysler and Dodge models equipped with the 3.6L engine. Made of strong polycarbonate. Creates a custom fit to valve covers and filler necks. Applicable: Chrysler Town and Country; Dodge Avenger, Challenger, Charger, Dart, Durango, Grand Caravan, Journey and Jeep Wrangler [2011– 2017].

- DO NOT USE BRAKE CLEAN



#OFHON1033
Oil Funnel



Fits various Acura, Ford, Honda, Jaguar, Jeep Land Rover, Mazda, and Nissan models. Applicable to Dodge Caravan [2010], Charger V8 [2017]; Fiat 500 [2012-2016]; Ford F-250 & -350 Power Stroke engines (6.9L, 7.3L, 6.0L and 6.4L); Honda Accord Civic, CR V, Element, Fit, Odyssey, Pilot, S2000 [1998–2018]; Jaguar 4.2L [2003-2009]; Jeep Wrangler [2001–2011], Land Rover Defender, Discovery, Range Rover [2002]; Mazda 2 [2013]; Nissan Altima [2016], Maxima [2008– 2016], Pathfinder [2010–2016], Rogue [2012– 2016], and Sentra [2013– 2016]; RAM Trucks 1500 [2012-2017].

- DO NOT USE BRAKE CLEAN
- For Honda/Acura SUV's and VAN's, the funnel needs to be used in conjunction with our #OFH33 Angled Extension.



#OFTOY1038
Threaded Toyota Oil Funnel



Applicable to all Lexus, Scion (except FR-S) and Toyota models with a threaded engine oil fill cap. For Toyota and Lexus 1/4 turn style oil caps, see #OFTOY1001.

- DO NOT USE BRAKE CLEAN

NOTE: FOR TOYOTA PRIUS AND YARIS, THE FUNNEL NEEDS TO BE USED IN CONJUNCTION WITH OUR #OFT38 ANGLED EXTENSION



#FUNCRY36
Adapter for 3.6L Chrysler, Dodge and Jeep



For use with our #FUN14KIT or #OFKIT. Applicable: Chrysler Town and Country; Dodge Avenger, Challenger, Charger, Dart, Durango, Grand Caravan, Journey and Jeep Wrangler [2011–2017].

- DO NOT USE BRAKE CLEAN

#OFH33
Funnel Extension for Honda and Acura



Oil funnel extension for our #OFHON1033 oil funnel. Adds coverage and access where normal funnels do not fit. Applicable to Acura MDX; Honda Pilot, Odyssey and Ridgeline.

- DO NOT USE BRAKE CLEAN

NOTE: USED IN CONJUNCTION WITH #OFHON1033 OR OFHON33 FUNNELS.

#OFT38
Funnel Extension for Toyota



Oil funnel extension for our #OFTOY1038 oil funnel. Applicable to Toyota Prius and Yaris. Adds coverage and access where normal funnels do not fit.

- DO NOT USE BRAKE CLEAN

NOTE: NOTE: MUST BE USED IN CONJUNCTION WITH #OFTOY1038 OR OFTOY38 FUNNELS.



WARNING:

These products can expose you to chemicals including Acrylonitrile & Styrene, which are known to the State of California to cause cancer and Bisphenol A (BpA) & Butadiene, which is known to the State of California to cause birth defects or other reproductive harm.



#FUN14KIT
6-Piece Custom Oil Funnel Set



Includes funnel and five adapters to fit over a hundred models including Acura, Aston Martin, Cadillac, Chevrolet, Dodge, Ford, GMC, Honda, Hyundai, Jaguar, Land Rover, Lotus, Lexus, Mazda, Nissan, Pontiac, Saab, Scion and Toyota. When combined with our other adapters, the 45 degree elbow extension allows access where funnels otherwise do not fit.

- DO NOT USE BRAKE CLEAN
- Includes five adapters to fit over a hundred models
- 45 Degree elbow extension allows access to where the funnel would otherwise not fit
- Subaru, Chrysler/Dodge/Jeep 3.6L and Euro adapters may be purchased separately

#OFHD419
Oil Funnel for Harley-Davidson



For the "push-in style" oil fill caps for Harley-Davidson Touring models [1999–2006].

- DO NOT USE BRAKE CLEAN



#OFHD35
Oil Funnel for KIA & Harley-Davidson



Applicable to Harley- Davidson Dyna [2007– 2016] and Touring [2007– 2017]; Kia Forte [2013– 2015], Optima [2016], Rio [2013-2016], Sedona [2015– 2016], Sorento [2011–2016], Soul [2013-2015] and Sportage [2014–2016].

- DO NOT USE BRAKE CLEAN



WARNING:

These products can expose you to chemicals including Acrylonitrile & Styrene, which are known to the State of California to cause cancer and Bisphenol A (BpA) & Butadiene, which is known to the State of California to cause birth defects or other reproductive harm.

#FUN14EURO
FUN14KIT Euro Adapter



For use with our #FUN14KIT. Specifically designed to attach to the valve covers on various Audi, BMW, Mercedes and Volkswagen models. When you're adding oil to the engine you don't have to worry about making a big mess due to the internal bafe of the valve cover.

- May not fit applications where cowl causes interference



#OFAUD1000
Euro 1/4-Turn Oil Filler



Specifically designed to attach to the valve covers. When you're adding oil to the engine you don't have to worry about making a big mess due to the internal bafe of the valve cover. Applicable to Audi, BMW; Dodge Sprinter; Mercedes; Porsche Cayenne and Panamera; VW/Audi 1.4L, 1.8L, 1.9L TDI, 2.0T, 2.8L, 3.0L, 3.2L, 3.6L and 4.2L engines; and Volvo 2.5L engines. Also fits Teledyne 550 and 520 engines found in Beechcraft and Cessna aircraft.

- May not fit applications where cowl causes interference.



NOTE: NOT APPLICABLE TO: [2012-2013] AUDI A8L 6.3L [W12] (12-CYL.) ENGINE. FOR [2015-2016] TDI AND HORIZONTALLY MOUNTED 2.0 TURBO, SEE FUNNEL #OFVW2013.

#OFVW2013
1/4 Turn Oil Funnel for VW/Audi



1/4 Turn funnel with four slots. Custom fit into valve cover for no mess filling of oil. Applicable to VW/Audi models with 1.8L and 2.0L turbo engines [2014-2018].





#2101 7-Piece Oil Filter Wrench Socket Set



Set contains oil filter wrench sockets for many domestic and foreign applications. Covers all Mercedes-Benz applications. The 27mm, 32mm and 36mm hex sizes cover VW/Audi, BMW, newer Mercedes engines, and GM 2.2 L Ecotec engines. Covers Ford Escape Hybrid and Ford OEM #FL 910 and #FL 793. Covers Chevrolet 2.2L and 2.4L engines [2007–2014], Dodge Sprinter and Volvo models. The four, cup-style wrenches cover many VW, BMW, Toyota and Mazda 3.

California Residents: Proposition 65
WARNING: See page 125 for info.



#23236 32 x 36mm Oil Filter Socket

Double sided 3/8" drive. Applicable to Audi Q3 and S3 2.0L Turbo [2015–2016], A6 3.0L [2014–2016], Q7 3.0L [2011–2016], Q7 3.6L [2007–2010]; BMW 335d and X5 35d [2009–2011], BMW 6 and 8 cyl. engines [1994–2005]; Chevy Cobalt, Impala and Malibu with 2.2L / 2.4L engines [2007–2014]; Porsche models [2009–2016]. VW TDI [2011–2016], Touareg [2009–2016] and VR6 motors and Volvo models [2007–2014].



#2124 Oil Filter Socket



Used for the R & R of the oil filter housing cap on BMW, Chrysler, Dodge, Jeep with 3.6L, Saturn and Chevy 4-cyl. EcoTec engines.

- 24mm - 6 Flats
- 3/8" Drive

#2127 Oil Filter Socket



Applicable to various models from Dodge Dart, Fiat, Hyundai, Kia and Mini models.

- 27mm - 6 Flats
- 3/8" Drive

#2132 Oil Filter Socket

Applicable to various models from Audi, BMW N57 diesel engine, Chevrolet 2.2L and 2.4L engines [2007–2014], Maserati, Saab, Saturn, and Volkswagen.

- 32mm - 6 Flats
- 3/8" Drive



#2136 Oil Filter Socket

BMW M52, M60, M62, M70 and M73 engines; Ford F-250 and F-350 6.0L turbo diesel [2004]; Mercedes OM604, 605 and 606; Mini Cooper/S [2002–2006]; Volkswagen Corrado, Eurovan VR6, Golf R32 3.2L VR6, Jetta 2.0L Turbo [2006], Jetta 2.8L VR6, Passat 2.8L VR6, Touareg and Volvo models with 36mm hex molded into the oil filter cap [2007–newer].

- 36mm - 6 Flats
- 3/8" Drive



#BM1276 Oil Filter Wrench

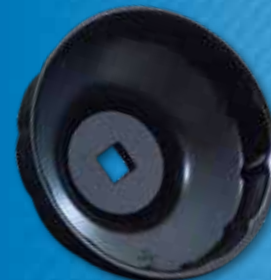

Used ON BMW i3 "Range Extender" engine [2014-2018] and for R & R of oil filter on BMW motorcycles [2007–2016] with oil filter #11 42 7 673 541. Also for R & R of 12 flute Mercedes OEM oil filters.

- 76mm - 12 flutes
- 3/8" Drive

NOTE: SOME NEW BMW MOTORCYCLES COME FROM FACTORY WITH FILTER ENDING IN '779'



#MO219 Oil Filter Wrench



Applicable to Audi, BMW motorcycle, Dodge, Ford, Mazda, Mercedes, Porsche, Toyota and VW.

- 74mm - 14 Flats
- Use with 22mm socket

COMPARABLE: MERCEDES #103 589 02 09 00

 California Residents: Proposition 65
WARNING. See page 125 for info.



#2175 Oil Filter Wrench



Applicable to various Mercedes and Volkswagen models. Also Fits newer Sprinter and Mercedes models with 2.1L turbo diesel engine [2015-2018].

- 74.5mm -14 Flats
- Use with 22mm socket

 California Residents: Proposition 65
WARNING. See page 125 for info.



#SU8015 Oil Filter Wrench

Applicable to Hyundai 4cyl. [1992-2012]; KIA [2001-2012]; Scion FR-S [2013-2016]; Subaru BRZ [2013-2018], Forester [2016-2018], Impreza WRX [2016-2018], Legacy (6-cyl.), Outback and Tribeca.

- 80mm - 15 Flats
- 3/8" Dive

FITS NAPA GOLD OIL FILTER #1334



#JAS6514 Oil Filter Wrench

Applicable to Honda vehicles [1987-2018]; Infiniti vehicles [2004-2018]; Jaguar F-Pace [2017], XE [2017], XF [2017]; Land Rover Evoque [2018]; Kawasaki Motorcycles [1990-2009]; Nissan 350Z [2002-2009], 370Z [2010-2018], Altima [1997-2018], Armada [2004-2018], Cube [2009-2014], Frontier [1997-2018], GT R [2008-2018], Juke [2011-2016], Maxima [1994-2018], Murano [2002-2018], Pathfinder [1995-2018], Quest [2006-2016], Rogue [2008-2018], Sentra [2001-2018], Titan [2003-2018], Versa [2006-2018] and Xterra [2002-2015]. Also works on Kawasaki factory filter #16097-0003 and Yamaha factory filter #5GH-13440-00. Also works on Powersports vehicles that utilize "HF303" oil filters including Honda, Polaris, Kawasaki and Yamaha.

- 65mm - 14 Flats
- 3/8" Drive



#MO284 Oil Filter Wrench



Used on Mercedes 3.0L V6 CRD (Diesel) engines found in Jeep Grand Cherokee [2007-2008]; Mercedes Bluetec engines in E 320 [2007-2009], E 350 [2011-2013], GL 320 [2009], GL 350 [2010-2013], ML 320 [2009], ML 350 [2010-2014], R 320 [2009], R 350 [2010-2013], S 350 [2012-2013] and Sprinter [2007-2015].

- 84mm - 14 Flats
- Use with 22mm socket

 California Residents: Proposition 65
WARNING. See page 125 for info.



#V410 Oil Filter Wrench



Applicable to BMW models with N52, N54, N55 and N63 engines [2006-2017]. Fits all Volvo Models [1999-2007] (except 2005 40 and 50 Series). For [2015-newer] Volvo, see #VB414.

- 86.5mm - 16 Flats
- Use with 22mm socket

COMPARABLE: BMW #119240 AND VOLVO #9995679

 California Residents: Proposition 65
WARNING. See page 125 for info.



#TOY647LG Oil Filter Wrench

NEW!



Applicable to Toyota V6 and V8 engines with canister style filter cartridge [2005-2019]. Does not fit on Sequoia.

- 64mm - 14 Flats
- 3/8" Drive



#JA19015 Oil Filter Wrench

Oil filter wrench for Jaguar and Land Rover models with the 3.0L v6 and 5.0L v8 engines [2010-2017].

- 90mm - 15 Flats
- 3/8" Drive



#VB414 Oil Filter Wrench for Volvo



Fits Volvo 2.0L turbo. Applicable to Volvo S60, S80, V60, XC60 and XC70 [2015-2019].

- 16 Flats
- Use with 22mm socket



California Residents: Proposition 65
WARNING. See page 125 for info.

#TOY300 Oil Filter Wrench Set for Toyota

Toyota 3-piece oil filter wrench set. With the #TOY300 you have every gas engine Toyota and Lexus model covered [1980-2019].

- Includes #TOY640, #TOY730 and #M0219.



California Residents: Proposition 65
WARNING. See page 125 for info.

#TOY730 Oil Filter Wrench

Applicable to Lexus ES 250 [1990-1991], ES 300[1992-2003], ES 300h [2013], ES 330 [2004-2006], GS 300 [1993- 2005], GS 400 [1998-2000], GS 430 [2001-2004], GX 470 [2004- 2009], IS 300 [2001-2005], LS 400 [1990-2000], LS 430 [2001- 2006], LX 450 [1996-1997], LX 470 [1998-2007], RX 300 [1999- 2003], RX 330 [2004- 2006], RX 400h [2006- 2008], SC 300 [1992- 2000], SC 400 [1992-2000], SC 430 [2002-2010]; Toyota 4Runner [2003-2009], FJ Cruiser [2007- 2009], Land Cruiser [1993-2007], Sequoia [2001-2009], Tacoma [2005- 2013] and Tundra [2000- 2010].

- 73mm - 14 Flats
- 3/8" Drive or Use 24mm or 15/16" socket



California Residents: Proposition 65
WARNING. See page 125 for info.

#HD1674 Oil Filter Wrench for Harley-Davidson



Oil filter wrench for [1980-2016] Harley-Davidson motorcycles with a spin on oil filter.

- 74mm - 14 Flats
- Use with 22mm socket

California Residents: Proposition 65
WARNING. See page 125 for info.



#TOY640 Oil Filter Wrench



Applicable to all Lexus / Scion /Toyota models with paper cartridge-style filter in Lexus 200h [2011- 2016], ES 350 [2007- 2018], GS 300 [2006-2018], GS 350 [2007-2018], GS 450h [2007-2018], GS 460 [2008-2011], GX 460 [2010-2018], HS 250h [2010- 2013], IS 250 [2006-2010], IS 250 C [2010-2016], IS 350 [2006-2018], IS 350 C [2010-2016], IS F [2008-2014], LS 460 [2007-2016], LS 600h [2008-2016], LX 570 [2008-2018], RX 350 [2007-2018], RX 450h [2010-2018]; Scion tC [2005-2016], xA [2004-2006], xB [2004-2016], xD [2008-2013]; Toyota 4Runner [1985- 2019], Avalon [1995- 2019], Camry [1983-2019], Corolla [1983-2019], Echo [2000- 2005], FJ Cruiser [2010-2014], Highlander [2001-2019], Prius [2001- 2019], Matrix [2003-2014], MR2 [1985-2005], Paseo [1992-1997], RAV4 [1996- 2019], Sequoia [2009-2016], Sienna [2007- 2019], Solara [1999-2009], Tundra [2007-2019], Venza [2009-2016] and Yaris [2006-2019].

- 64mm - 14 Flats
- Use with 24mm or 15/16" socket

COMPARABLE: #09228-06501 AND #09228-06500-02

California Residents: Proposition 65
WARNING. See page 125 for info.



#M0721
Engine Oil Dipstick

Used for checking engine oil level on Mercedes models with 112,113, 137 and 271 engines that do not have an engine dipstick.

COMPARABLE:
MERCEDES #120 589 07 21 00



DETAILED VIEW



#CRY323
Transmission Dipstick



Stainless steel design and clear level marks with a knurled handle. Applicable to all 6F24 6-speed and 948TE 9-speed automatic transmissions found in Dodge Dart [2012-2016], Fiat 500 [2012-2017]; Jeep Cherokee [2014-2017], Compass [2014], Patriot [2014] and Renegade [2015-2017].

COMPARABLE: MOPAR #10323A

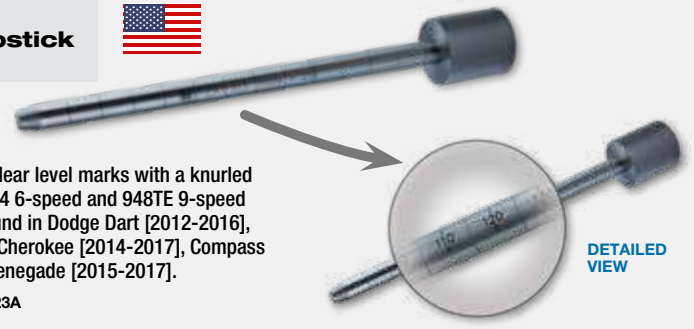

DETAILED VIEW

#M7226
Transmission Dipstick for Mercedes 722.6



Used for checking ATF level in Mercedes models with 722.6 transmission [1997-2006]; Freightliner Sprinter [2010-2016] and Jaguar models with W5A580, Jaguar XKR [2000-2002].

COMPARABLE: JAGUAR #307-379 AND MERCEDES #140 589 15 21 00.

#M21250
Transmission Dipstick



Used for checking ATF level in Mercedes CLA and GLA models with the 724 Transmission [2014-2017].

COMPARABLE: #168589012100

#AU40178
Engine Oil Dipstick

Applicable to Audi A4 [2009-2017], A5 [2009-2015], A6 [2009-2015], A8 [2011-2014], Q5 [2013-2015], RS5 [2013-2015], S4 [2010-2015], S5 [2009-2012], S6 [2013-2015], S7 [2013-2015]; Porsche Cayenne S Hybrid [2011-2014], Panamera S Hybrid [2012-2014]; Volkswagen Touareg [2011-2014].

COMPARABLE: #T 40178



DETAILED VIEW



#CRY933
Transmission Dipstick for Chrysler

Used on all vehicles equipped with a NAG1, 42RLE, 62TE and CVT transmission. Applicable to Chrysler 200 [2011-2014], 300 [2006-2014], Aspen [2008-2009], Pacifica [2007-2008] Sebring [2007-2013], Town & Country [2008-2017]; Dodge Avenger [2007-2014], Caliber [2007-2012], Challenger [2008-2014], Charger [2006-2014], Dakota [2008-2011], Durango [2008-2013], Grand Caravan [2008-2017], Journey [2009-2014], Magnum [2006-2013], Nitro [2007-2011], Promaster [2014-2017], Ram [2007-2013], Jeep Commander [2006-2010], Grand Cherokee [2006-2013], Liberty [2006-2012], Patriot [2007-2013] and Volkswagen Routan [2009-2014].

COMPARABLE: #9336 AND #9336A.



#SPR886
Transmission Dipstick for Sprinter and Crossfire

Used on Dodge / Freightliner Sprinter [2002-2009] and Chrysler Crossfire [2004-2008].

COMPARABLE: CHRYSLER #8863B



DETAILED VIEW





#6300 12-point Socket Bit Set for VW/Audi

7-Piece set includes sockets:

- #6300XL-14 (long 14mm)
- #6300XL-8 (long 8mm)
- #6300XL-10 (long 10mm)
- #6300X-16 (16mm tamper-proof)
- #6300X-12 (12mm bit)
- #6300X-14 (14mm bit)
- #3424 (Spreader)



#3462 Head Bolt Socket



Applicable to most VW/Audi engines [1998–newer].

- #10 Polydrive
- 1/2" Drive
- 155mm Length

COMPARABLE:
#3452, #3452A AND #T10070



#3424 Spreader



For the R & R of the front shock absorber tube from the wheel bearing housing. Applicable to Audi A3 [2006–2008], TT [2000–2008] and A5 [2008–2009]; Volkswagen Golf, Beetle [1999–2008], Rabbit, GTI, Passat [2006–2008], Jetta [1999–2006], Tiguan [2008].

- 3/8" Drive



#6300X-12 12mm, 12-Point Socket Bit

For the R & R of axle shaft bolts on newer VW Jetta and rear toe adjustment on Audi A6 [1999–newer]. Used for bell housing bolts with tight clearance on various VW models.



#6300X-14 14mm, 12-Point Socket Bit

For R & R of Audi TT differential bracket and for bell housing bolts with tight clearance on various VW models.



#6300X-16 12-Point Tamperproof Socket

Used for R & R of manual transmission drain plug. Applicable: Audi Q7, Porsche Cayenne and VW Touareg brake caliper bolts.

- 16mm Tamper-proof
- 1/2" Drive
- 60mm Length

COMPARABLE: #904 589 00 10 00



#6300XL-8 12-Point Long Socket

Used for R & R of axle shaft bolts on VW Beetle, Jetta TDI and older VW/Audi models.

- 8mm
- 3/8" Drive
- 90mm Length



#6300XL-10 12-Point Long Socket

Used for R & R of axle shaft bolts on Volkswagen Golf and Passat.

- 10mm
- 3/8" Drive
- 90mm Length



#6300XL-14 12-Point Long Socket

Used for R & R of late model VW Eurovan axle shafts and ball joints. Also used on VW Touareg inner CV bolts.

- 14mm
- 1/2" Drive
- 140mm Length



#6355X-14
12-Point Socket

Ideal for use on rear brake caliper bolts on VW Jetta and Passat [2006– newer].

- 14mm
- 1/2" Drive
- 64mm Length



#6500TPT-100
Torx Socket

Used to remove and replace the camshaft adjuster central valve on Mercedes 274, 276, 270, 278 and 271 engines [2012-2016].

- T-100 Tamper-proof
- 1/2" Drive
- 95mm Length

COMPARABLE: MERCEDES #271589001000



#6500X-18
12-Point Socket

Used for R & R of the rear axle bolts on VW Jetta and Golf [2006–2015].

- 18mm
- 1/2" Drive
- 95mm Length

COMPARABLE: #T10162



#6500TL-80
Torx Socket

NEW!

Used on BMW for R & R of driver's side wiper arm on E31, E38 and E39 chassis. Also fits Lamborghini wheel lug bolts on Gallardo models.

- T-80 Tamper-proof
- 1/2" Drive
- 100mm Length



#6500T-100
Torx Socket

Used to remove parts to allow access for brake jobs on MAN Commercial Buses.

- T-100
- 3/4" Drive
- 60mm Length



#6500X-24
12-Point Socket

For R & R of front axle bolt. Applicable: VW Golf [2010–2013] and Tiguan [2009–2015].

- 24mm
- 1/2" Drive
- 38mm Length

COMPARABLE: #T 10361



#6500-14
Allen Socket

Applicable to Audi A4 Quattro front & rear axle bolts [1996–2001] and VW Passat rear axle bolts [1996–2002].

- 14mm
- 1/2" Drive
- 37mm Length



#6500-17
Allen Socket

Applicable to Audi A4 (AWD) front & rear axle bolts [2002–2009], Audi A6 front axle bolts [1999–2009] and VW Passat front axle bolts [1998–2005].

- 17mm
- 1/2" Drive
- 38mm Length



#6500X-30
12-Point Socket

Used For R & R of front axle nuts. Applicable: [1999–2005] VW Cabrio, Beetle, Golf and Jetta.

- 30mm
- 1/2" Drive
- 45mm Length



#6506
Axle Nut Socket Set for VW/Audi

6-Piece set includes sockets:

- #6500-14
- #6500-17
- #6500X-18
- #6500X-24
- #6500X-30
- #6500X-32

NOTE: FOR [2009–NEWER] AUDI A4 REAR AXLE BOLTS, ORDER #H985-19.



#6500X-32
12-Point Socket

Used for R & R of front and rear axle nuts on [2004–2016] VW Touareg.

- 32mm
- 3/4" Drive
- 60mm Length





#100-30A 12-Point Deep Socket

Used for R & R of transmission drive shaft flange nut and pinion shaft flange nut of differential. Applicable: many BMW, Mercedes and Toyota models with 30mm, 12pt axle nuts.

- 30mm
- 1/2" Drive
- 85mm Length
- Thin-walled



#3900 5-Lobe Tamperproof Bit Set

5 Lobe bits and a 1/4" drive. Includes: T-10, T-15, T-20, T-25, T-27, T-30, T-40, T-45 and T-50. Applicable to various BMW, Mercedes, VW and Volvo models.



#M8160 Extra Long 8mm Socket



Used for R&R of rear tail light assembly on Mercedes models [2017-2018].

- 1/4" Drive
- 160mm Length



#BMW10160 Extra Long 10mm Socket



Applicable to Mercedes-Benz rear bumpers and used for R & R of the ground connector screw for the injector on BMW N54 engines.

- 1/4" Drive
- 160mm Length

FOR TAIL LIGHT ASSEMBLY ON NEWER MERCEDES, ALSO ORDER M8160



#BMW11850 Head Bolt Socket for BMW



Used on 3 of the head bolts on BMW N52, N54 and N55 engines. For all of the remaining head bolts on these engines use our #BMW11860.

- T-50
- 1/2" Drive
- 165mm Length

COMPARABLE: #114420

#BMW11860 Head Bolt Socket for BMW



Used on BMW N51, N52, N54 & N55 engines. Used in conjunction with #BMW11850.

- T-60
- 1/2" Drive
- 195mm Length

COMPARABLE: BMW #118580

#BFLT60
Machined T-60
Socket



Special machined, long T60 Torx socket is machined for clearance to access the rear wheel bearing bolts without hitting the ABS rotor sensor on Ford Edge/ Lincoln MKX. Also used for R and R of flywheel bolts on BMW E34 and E39 [V8] 4.0L 4.4L & 5.0L with standard transmission.

- 1/2" Drive
- 140mm Length

COMPARABLE: #114180

#EU2090
Allen Socket

Applicable to Volvo front caliper slide bolts [2010–2015].

- 9mm
- 3/8" Drive
- 50mm Length



#6300T-50
Torx Socket

NEW!

Used in conjunction with #ALT34018 on KIA and Mercedes Alternator Pulley Bolts.

- T-50
- 3/8" Drive
- 70mm Length



#BMW377
Allen Socket

Used for easy removal of the rear brake caliper slide bolts on BMW E36, E46, E39 and E31 models, and Mercedes S Class (221).

- 7mm
- 3/8" Drive
- 32mm Length



#H985-19
Allen Socket



Used on Audi A4 rear axle bolts [2009–newer] and anywhere a 19mm Allen socket is needed on Audi, Mercedes, Porsche, and VW.

- 19mm
- 1/2" Drive
- 42mm Length



#H2223LGT-30
Torx Socket Insert



Used for the R & R of the airbag from the steering wheel. Applicable to BMW, Mercedes [1998–2002], Saab, Volkswagen [1994–2002] and Volvo.

- T-30
- 70mm Length



#H2850-E24
Female
Torx Socket



Used for R & R of head bolts on International and Man commercial vehicles which use MAN D20, D25 and D28 engines.

- E24
- 3/4" Drive
- 110mm Length



#TSE10TP5
Tesla E10 5
Lobe Socket

NEW!



Used to remove the license plate bracket fasteners on model S and used on Model 3 to remove the electrical connectors.

- E10 - 5 Point
- 1/4" Drive
- 25mm Length



DANGER:

Caution when using on electric vehicles, High Voltage Shock possible

#N512
Socket for Nissan

Applicable to the Flywheel bolts used on Nissan models.

- E12
- 1/2" Drive
- 37mm Length



#HO10PT
10-Point Socket

Applicable: [2001–newer] Honda Civic and Acura RSX rear lower control arms.

- 16mm
- 1/2" Drive
- 40mm Length





#BMW11845 Torx Socket

Used for BMW VANOS housing bolts.

- T-45 Tamper-proof
- 3/8" Drive
- 100mm Length



#MOE24 Female Torx Socket

Used on front axle nut on All Wheel Drive Mercedes C 230, C 300, C 350 [2008–2009], C 250, C 300, C 350 [2010–2011], C 300, C 350 [2012–2014], C 350 [2015], E 350, E 550 [2010–2014], E 350 [2015–2016] and S 550 [2007–2013].

- E24
- 1/2" Drive
- 78mm Length



#M1020 Glow Plug Socket



Glow plug socket for Dodge Sprinter.

- 10mm
- 3/8" Drive

#MSP1412 Magnetic Spark Plug Socket

Fits BMW, BMW Motorcycles, Ford, Mini, Nissan, Porsche, Scion, Subaru and Toyota.

- 14mm - 12 Point
- 3/8" Drive
- Strong internal magnet holds spark plug firmly

NOTE: SPARK PLUG SOCKET IS SLENDER IN DESIGN TO FIT APPLICATION.



#M820 Glow Plug Socket



Glow plug socket for Mercedes and Sprinter.

- 8mm
- 3/8" Drive

#M17XLWS Long Mercedes Lug Bolt Socket

Used to R & R the "Flower Shaped" lug bolt on Maybach and Mercedes 221 S class and late model CL class. Fits Mercedes wheel lug bolt part #0009905407.

- 1/2" Drive
- 86mm Length



#M17WLS Mercedes Lug Bolt Socket

Used to R & R the "Flower Shaped" lug bolt on Maybach and Mercedes 221 S-class and late model CL class. Fits Mercedes wheel lug bolt part #0009905407.

- 1/2" Drive
- 50mm Length



#SP1412
Spark Plug Socket

Fits BMW, BMW Motorcycles, Ford, Mini, Nissan, Porsche, Scion, Subaru and Toyota.

- 14mm - 12 Point
- 3/8" Drive
- Rubber boot to hold spark plug

COMPARABLE: BMW #121220

NOTE: SPARK PLUG SOCKET IS SLENDER IN DESIGN TO FIT APPLICATION.



#S3054X-10
12-Point Socket



Used for R and R of cylinder head bolts. Applicable to Mercedes OM 601, OM 602 and OM 603 engines; Pontiac Vibe [2003-2007]; Toyota Matrix [2003-2007]; Volkswagen and Audi 10mm, 12-point head bolts.

- 10mm
- 1/2" Drive
- 140mm Length

NOTE: MOST [1998-NEWER] VW/AUDI APPLICATIONS REQUIRE THE #3462 HEAD BOLT SOCKET.

COMPARABLE: MERCEDES #601589001000, VW #3410 AND VOLVO #9512849.



#S3054X-12
12-Point Socket



Applicable to Mercedes head bolts on OM 615, 616, 617, M 102, and M 103 engines; for R and R of cylinder head bolts on Toyota 4Runner V6 [2003], all 2ZZ engines with VVT including Toyota Celica [2000-2001] and Highlander 2AZ-FE engines [2001-2006]; older Volkswagen and Audi models with 12mm, 12-point head bolts.

- 12mm
- 1/2" Drive
- 140mm Length

NOTE: MOST [1998-NEWER] VW/AUDI APPLICATIONS REQUIRE THE #3462 HEAD BOLT SOCKET.

COMPARABLE: MERCEDES #617589001000



#SU070
Drain Plug Socket for Subaru

Used for R & R of the drain plug on Manual Transmission. Applicable to Subaru with manual transmission [2003-2016]

- T-70
- 1/2" Drive
- 105mm Length



#S40-300
3mm Socket



Used on Audi A6 [2012+] Fuel Door Actuators and any place a 3mm socket is needed.

- 1/4" Drive
- 25mm Length



#3035
3.5mm Socket

Used for R & R of the Proximity (Radar) Sensors and any place a 3.5mm socket is needed.

- 1/4" Drive
- 25mm Length



#TOY105
Head Bolt Socket

Used for head bolt sockets on newer Toyota models that use a special #8 bi-hexagon socket. Applicable: Toyota Paseo, Prius [2001-2009], Tercel and Yaris [2006-2013].

- #8 Bi-Hexagon
- 1/2" Drive
- 100mm Length



#T10107B
Long Allen Socket

Fits right hand stub shaft: 6-speed manual, OA5 and 02N and VW 2.5L I5 (4v) intake manifold bolts, Jetta (BGP & BGQ) [2005-2007], Jetta (CBTA & CBUA) [2008-2014], Rabbit (BGP & BGQ) [2006-2007], Rabbit (CBTA & CBUA) [2008-2009], Beetle (BPR & BPS) [2006-2010] and Beetle (CBTA & CBUA) [2012-2014].

- 6mm
- 3/8" Drive
- 325mm Length

COMPARABLE: #T10107A

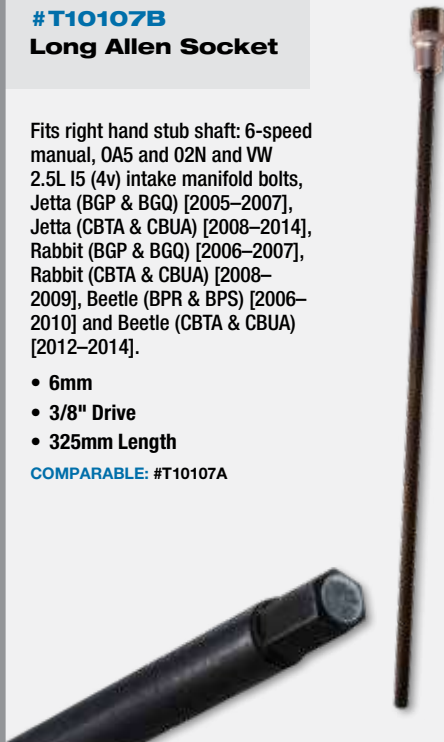

#VW5220
Camshaft Adjuster Socket

Used for camshaft adjuster bolt on VW/Audi 2.0L turbo (BPG) (BPY) engines.

- #10 Polydrive
- 1/2" Drive
- 53mm Length

COMPARABLE: #T40080





Individual Stud Removers / Installers

3/8" & 1/2" Drive except #200-9/16 & #200-5/8 which are 27mm Hex.



#200-6
6mm



#200-7
7mm



#200-8
8mm



#200-10
10mm



#200-12
12mm



#200-1/4
1/4"



#200-5/16
5/16"



#200-3/8
3/8"



#200-7/16
7/16"



#200-1/2
1/2"



#200-9/16
9/16"



#200-5/8
5/8"



The AST Production Year is stamped on the stud remover. Stud removers are warranted for 10 years from this date.

Stud Removers: Stud removers are warranted for 10 years.

External body: The production year is stamped on the stud remover. Only if the external body is damaged, should the stud puller be sent in, if it is within the 10 year warranty.

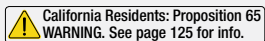

Parts Kit for Stud Removers / Installers



Internal Parts Kit contains: cage, three rollers, clip, and washer

Internal parts: DO NOT send in your stud remover that only needs the internal parts replaced. Simply call for assistance and we will send out a replacement parts kit [at no charge while under warranty]. The table to the right indicates replacement numbers for the internal parts.

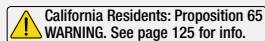

STUD REMOVER SIZE INTERNAL PARTS KIT #

6mm	#60
7mm	#70
8mm	#80
10mm	#100
12mm	#120
1/4"	#250
5/16"	#312
3/8"	#375
7/16"	#437
1/2"	#500
9/16"	#562
5/8"	#625

#201
4-Piece Metric Stud Puller Set

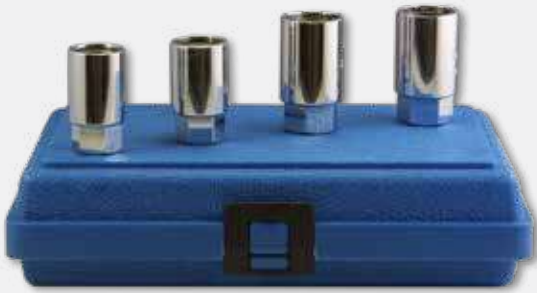

4-Piece stud remover set. Includes 6mm, 8mm, 10mm and 12mm stud remover tools. Works on most makes and models. Multiple applications. Carrying case included.

California Residents: Proposition 65
 WARNING. See page 125 for info.

#201-7
5-Piece Metric Stud Puller Set



5-Piece metric stud remover set. Includes 6mm, 7mm, 8mm, 10mm and 12mm stud remover tools.

California Residents: Proposition 65
 WARNING. See page 125 for info.

#202
5-Piece Standard Stud Puller Set



5-Piece standard stud remover set. Includes 1/4, 5/16, 3/8, 7/16, and 1/2 inch stud remover tools. Works on most makes and models.

California Residents: Proposition 65
 WARNING. See page 125 for info.

#203
7-Piece Standard Stud Puller Set



7-Piece standard stud remover set. Includes 1/4, 5/16, 3/8, 7/16, 1/2, 9/16, and 5/8 inch stud remover tools. Works on most makes and models.

California Residents: Proposition 65
 WARNING. See page 125 for info.

#SR101
Stud Remover and Installer Set

Pieces thread onto broken studs, lock together and are turned out with a socket or wrench.

- Contains sizes:
 M6 x 1.0, M8 x 1.25,
 M10 x 1.25 and M10 x 1.5





#3810
6-Piece File Set

Includes the following six files and a protective case: flat file, flat file / tapered front, round file, triangle file, square file and a half round / half flat file.



DETAILED VIEW OF FILE TIPS SHOWN HERE

#VW93005
Connector Release Tool

Used to remove flat terminals with two release tangs from the connector plug (1mm wide, 2.5mm apart and 16mm long). Replaces #S 1556 N.



#M8160
Extra Long 8mm Socket



Used for R & R of rear tail light assembly on Mercedes models [2017-2018].

- 1/4" Drive
- 160mm Length

#BMW10160
Extra Long 10mm Socket



Used for R & R of the ground connector screw for the injector on BMW N54 engines and Mercedes-Benz rear bumpers.

- 1/4" Drive
- 160mm Length

COMPARABLE: #118620

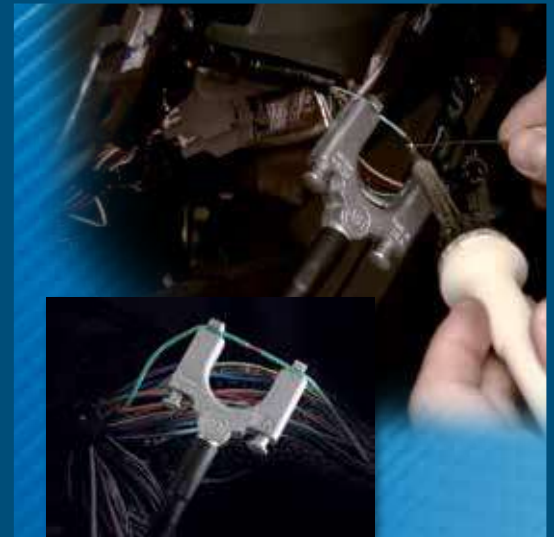

#WSC15
Wire Soldering Clamp



This clamp tool is an ideal solution for holding wires in place during soldering. It is a second set of hands, clamping down onto wires from either side of the tool. Holds firmly and may be used for various gauges of wiring.

- Six inch flex cable for difficult to reach areas
- Spring-loaded, sliding claws clamp onto wires firmly
- Extra strong magnetic base provides ample support
- Frame and Claws Made in USA from Diecast Aluminum



#MW35
Hard Black Wedge Set



Constructed of strong black polycarbonate, this set of three wedge-style dash panel removal tools allows installers to remove oil pans, rocker covers and more, without causing damage.



- More Ridgid than the Orange #MW 34 Set and used on Much Heavier Jobs

California Residents: Proposition 65 WARNING. See page 125 for info.

#3206
Door, Trim and Molding Tool Set



Set includes a T-25 long Torx screwdriver for accessing door handles on various BMW and Mercedes models. One trim spoon and one light duty hook is included for various interior jobs. Includes a specialty door handle tool for VW Tiguan models, as well as one pair of trim and cluster hooks. Three soft wedges are also included for various trim and molding jobs both for interior and exterior applications. Includes carrying pouch.



#MW34
Soft Orange Wedge Set



Constructed of soft orange polyethylene, this set of three wedge-style dash panel removal tools allows installers to remove dash trim bezels and other vehicle interior moldings including door panels, without causing damage. Great for installing electronics.



- Three Diverse Sizes for Various Uses

#M0333
Puller Set (pair of hooks)



Used for R & R of the instrument cluster on Mercedes models. Applicable: Mercedes W 107, 116, 123, 124, 126, 129, 140, 168, 170, 201, 202, 208, 210 and 463 chassis.

#T10389
Assembly Tool



For removal and installation of the lock cylinder housing on doors with no lock cylinder. Applicable to VW Tiguan [2009-2016].

INCLUDED IN #3206 SET

#T10518A
Grab Handle Release Tool



Used to remove the roof grab handle of the Golf [2013-2017] and Tiguan [2016-2017] without causing damage.

#3316
Radio Removal Keys



For removing the factory installed radio. Applicable: new body style VW Passat [1999-2005] and Jetta and Golf [1999-2005] with vertically aligned key slots.



#3344A
Radio Removal Tool



For radio removal on Audi A4, A6, A8 and VW new Beetle models with horizontally aligned key slots. Two pair required in most cases.

COMPARABLE: VW #T 10057



#HD1674
Oil Filter Wrench for Harley-Davidson



For Harley Davidson motorcycles [1980–2016] with a spin on oil filter. Machined, window design clears the crank sensor.

- 74mm - 14 Flats
- Use with 22mm socket

California Residents: Proposition 65
WARNING. See page 125 for info.



#MO219
Oil Filter Wrench



Used on BMW motorcycles F650, F800, K100, K1100, K1200GT [2003–2004], K1200LT, K1200R, K1200RS [1996–2004], K1200S, K1300, K75, R1100, R1150, R1200C, R1200CL, R1200GSW [2013–2014], R850 and S1000RR.

- 74mm - 14 Flats
- Use with 22mm socket

California Residents: Proposition 65
WARNING. See page 125 for info.



#JAS6514
Oil Filter Wrench

Applicable to Honda and Nissan vehicles. Kawasaki factory filter #16097-0003 and Yamaha factory filter #5GH-13440-00. Also works on Powersports vehicles that utilize "HF303" oil filters including Honda, Polaris, Kawasaki and Yamaha.

- 65mm - 14 Flats
- 3/8" Drive



#BM1276
Oil Filter Wrench

For R & R of oil filter on BMW motorcycles [2007–2016] with oil filter #11 42 7 673 541 found on BMW F650F, F800GS, HP2, K 1600 GTL /GT, K1200GT [2006– 2008], K1200R/SPORT, K1200S, R 1200 ST, R1200GS, R1200R, R1200RT, R1200S and S 1000 RR.

- 76mm - 12 Flutes
- 3/8" Drive



#FZ13818
Adapter



For pressurizing cooling system. Works with many Asian and domestic models. Applicable: vehicles with small, shallow necks.

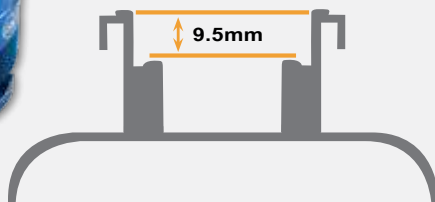

#OFHD35
Oil Funnel for Harley-Davidson



Oil funnel that threads on and seals just like the Harley-Davidson oil cap. Applicable to Harley-Davidson Dyna [2007–2016] and Touring models.

- DO NOT USE BRAKE CLEAN

California Residents: Proposition 65
WARNING. See page 125 for info.



#OFHD419
Oil Funnel for Harley-Davidson



For the "push-in style" oil fil caps for [1999–2006] Harley-Davidson touring models.

- DO NOT USE BRAKE CLEAN

California Residents: Proposition 65
WARNING. See page 125 for info.



#3035
3.5mm Socket

Used for R & R of the Proximity (Radar) Sensors on Tesla vehicles.

- 1/4" Drive
- 25mm Length



#TSE10TP5
Tesla E10 5 Lobe Socket

NEW!



1/4" Drive. Used to remove the license plate bracket fasteners on model S and used on Model 3 to remove the electrical connectors.

- E10 - 5 Point
- 1/4" Drive
- 25mm Length

 **DANGER:**
Caution when using on electric vehicles, High Voltage Shock possible

#ATFBASIC
Basic Driveline Filler

Applicable to Nissan Leaf to fill the gear reduction assembly and on Tesla Drive lines. U.S. made container, made of UHDP (ultra high density polyethylene). Newly designed drum features a second port for filling or dumping fluids without having to remove the pump-saving both time and clean up afterwards.

- Used only to Fill, Not to Drain—So Clean Fluid Stays Clean
- 8 Liter Capacity
- Quick Attachment Adapters
- Pump Dispenses Efficiently
- On/Off Ball Valve
- Hose Length: 4ft 10in



ATF CONTAINER IS
MADE IN USA





#TM1215
Ball Joint Hammer Nut

NEW!

Used for breaking free steering knuckle/
suspension joints using an impact hammer.
Nut must be threaded all the way onto knuckle/
suspension joints threaded shafts.

- M12 x 1.5 Threads
- 22mm - 7/8" Hex



NOTE: FOR THE COMPLETE 4PC. SET, PURCHASE
THE #TM20194 CONTAINING M12X1.25, M12X1.5,
M14X1.5 AND M16X1.5.

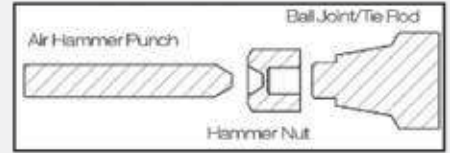

#TM1415
Ball Joint Hammer Nut

NEW!

Used for breaking free steering knuckle/
suspension joints using an impact hammer.
Nut must be threaded all the way onto knuckle/
suspension joints threaded shafts.

- M14 x 1.5 Threads
- 22mm - 7/8" Hex



#TOY640
Oil Filter Wrench



Applicable to all models with paper cartridge-style filter in Lexus CT 200h [2011–2016], GS 450h [2007–2018], HS 250h [2010–2013], LS 600h [2008–2016], RX 450h [2010–2018]; Toyota Avalon Hybrid [2013–2019], Camry Hybrid [2007–2019], Highlander Hybrid [2006–2019], Prius [2001–2019] and RAV4 Hybrid [2016–2019].

- 64mm -14 Flats
- Use 24mm or 15/16" socket

COMPARABLE: #09228-06501 AND #09228-06500-02

California Residents: Proposition 65
WARNING. See page 125 for info.

#FZ148
Tank Adapter



For pressurizing cooling system. Applicable to Lexus CT 200h [2011–2016], GS 450h [2007–2018], HS 250h [2010–2013], LS 600h [2008–2016], RX 450h [2010–2018]; Toyota Avalon Hybrid [2013–2019], Camry Hybrid [2007–2019], Highlander Hybrid [2006–2019], Prius [2001–2019] and RAV4 Hybrid [2016–2019].

- M34 x 3 Threads

#FZ25
Tank Adapter



For pressurizing cooling system . Applicable to BMW Hybrid Models 330e, 530e, 740e and X5 40e [2016–2019]; BMW Electric Models i3 and i8 [2014–2019].

- M47 x 3 Threads

APPENDIX

APPLICATION CHARTS	110-124
CALIFORNIA PROP 65 WARNINGS	125





BMW345 Tank Adapter

- M51 x 4 Threads



MAKE / MODEL

YEAR RANGE

BMW – 318i	[1996–2005]
BMW – 323i	[1999]
BMW – 323is	[1996–2005]
BMW – 325i	[2004]
BMW – 328i	[1996–2005]
BMW – 330ci	[1996–2005]
BMW – 330xi	[1996–2005]
BMW – 530i	[1997–2003]

MAKE / MODEL

YEAR RANGE

BMW – 540i	[1997–2003]
BMW – 740i	[1995–2000]
BMW – 745i	[2002–2004]
BMW – X3	[1990–2003]
BMW – X5	[2005–2006]
BMW – Z3	[1996–2005]
BMW – Z4	[1996–2005]
BMW – Z8	[2001]

MAKE / MODEL

YEAR RANGE

Land Rover – Discovery	[1999–2004]
Land Rover – Range Rover	[1995–2004]



BMW350 Tank Adapter

- M52 x 3 Threads

*ATTENTION:

THE BMW 350 MAY NOT FIT ON [2014–JANUARY 2016] BMW 750i. THE TANK HAS DIFFERENT THREADS AND BMW SUPERSEDED THE TANK TO A NEW CORRECTED PART NUMBER. CARS MADE AFTER JANUARY OF 2016 HAVE THE SUPERSEDED TANK AND THE BMW 350 WORKS PERFECTLY.

MAKE / MODEL

YEAR RANGE

BMW – 128i	[2008–2013]
BMW – 135i	[2008–2013]
BMW – 135is	[2013]
BMW – 230i	[2017–2018]
BMW – 320i	[2012–2013]
BMW – 323i	[2006–2011]
BMW – 325Ci	[2006]
BMW – 325i	[2006]
BMW – 325xi	[2006]
BMW – 328Ci	[2007–2012]
BMW – 328i	[2007–2018]
BMW – 328xi	[2007–2012]
BMW – 330Ci	[2006]
BMW – 330e	[2017–2018]
BMW – 330i	[2006–2018]
BMW – 330xi	[2006]
BMW – 335Ci	[2007–2012]
BMW – 335d	[2009–2011]
BMW – 335i	[2007–2013]

MAKE / MODEL

YEAR RANGE

BMW – 335is	[2011–2013]
BMW – 335xi	[2007–2012]
BMW – 430i	[2017–2019]
BMW – 525	[2004–2005]
BMW – 525i	[2007]
BMW – 525xi	[2007]
BMW – 528i	[2009–2013]
BMW – 528xi	[2008–2010]
BMW – 530	[2004–2005]
BMW – 530e	[2012–2013]
BMW – 530i	[2006–2018]
BMW – 530xi	[2006–2007]
BMW – 535d	[2014–2015]
BMW – 535i	[2008–2016]
BMW – 535xi	[2008–2010]
BMW – 540i	[2017–2018]
BMW – 545	[2004–2005]
BMW – 550	[2006–2007]
BMW – 550i	[2008–2013]

MAKE / MODEL

YEAR RANGE

BMW – 640i	[2012–2018]
BMW – 645Ci	[2004–2005]
BMW – 650i	[2006–2018]
BMW – 740e	[2016–2018]
BMW – 740i	[2008–2015]
BMW – 750i	[2009–2018]
	*SEE NOTE
BMW – 750Li	[2009–2013]
BMW – X3	[2007–2018]
BMW – X4	[2016–2018]
BMW – X5	[2007–2018]
BMW – Z4	[2009–2016]





#FZ13818
Coolant Adapter

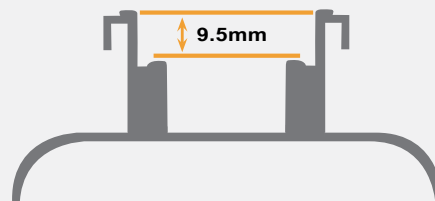

MAKE / MODEL	YEAR RANGE
Acura – MDX	[2018]
Acura – Clarity	[2018]
Chevrolet – Metro	[1998–1998]
Chevrolet – Prizm	[1998–1998]
Chevrolet – Tracker	[1998–1998]
Chrysler – Colt	[1993]
Chrysler – Summit	[1993–1995]
Honda – Accord	[1994–2016]
Honda – Civic	[1994–2015]
Honda – CR-V	[2014]
Honda – Element	[2008]
Honda – Odyssey	[1999–2018]
Honda – Pilot	[2003–2016]
Honda – S2000	[2008]
Isuzu – All Models	[1998–1999]
Lexus – ES 300	[1992–1993]
Lexus – GS 300	[1993–1999]
Lexus – GS 400	[1989–1999]

MAKE / MODEL	YEAR RANGE
Lexus – RX 300	[2000]
Mazda – 5	[2007]
Mazda – Protege	[2000–2003]
Mitsubishi – Diamante	[1996–1998]
Mitsubishi – Eclipse Spyder	[2002]
Mitsubishi – Galant	[1994–2003]
Mitsubishi – Mirage	[1993–1999]
Scion – FR-S	[2013–2016]
Scion – tC	[2008]
Subaru – (6-cyl.) models	[2001–2016]
Subaru – Ascent	[2019]
Subaru – BRZ	[2013–2017]
Subaru – Forester	[2016]
Subaru – Impreza	[2006–2018]
Subaru – Legacy	[2016]
Subaru – Outback	[2006–2018]
Subaru – Tribeca B9	[2006]
Subaru – XV Crosstrek	[2013–2018]

MAKE / MODEL	YEAR RANGE
Toyota – 4Runner	[2001–2019]
Toyota – Avalon	[2011–2016]
Toyota – Camry	[1992–2019]
Toyota – Celica	[1990–1998]
Toyota – Corolla	[1993–2016]
Toyota – Echo	[2000–2003]
Toyota – FJ Cruiser	[2007–2014]
Toyota – Highlander	[2001–2019]
Toyota – Matrix	[2003–2013]
Toyota – Paseo	[1992–1999]
Toyota – RAV4	[1996–2016]
Toyota – Sequoia	[2001–2003]
Toyota – Sienna	[2010–2019]
Toyota – Supra	[1992–1997]
Toyota – Tacoma	[2006–2016]
Toyota – Tercel	[1991–1999]
Toyota – Tundra	[2000–2019]
Toyota – Venza	[2011–2016]
Toyota – Yaris	[2011–2016]



#FZ148
Tank Adapter

- M34 x 3 Threads

MAKE / MODEL	YEAR RANGE
Lexus – LS 460	[2007–2013]
Lotus – Elise	[2005]
Scion – tC	[2011–2016]
Scion – xB	[2011–2013]

MAKE / MODEL	YEAR RANGE
Toyota – Celica GTS-S	All Applicable
Toyota – Highlander	[2006–2010]
Toyota – MR2 Spyder	All Applicable
Toyota – Prius	[2001–2016]
Toyota – RAV4	[2006–2018]



#FZ163 Cooling System Adapter



MAKE / MODEL	YEAR RANGE
Porsche – Boxster	[2007–2012]
Porsche – Cayman	[2005–2013]



#FZ22 Tank Adapter

- M48 x 3 Threads



MAKE / MODEL	YEAR RANGE
Audi – Models with male threads on exp. tank	[1975–1993]
Audi – A8	[1999]

MAKE / MODEL	YEAR RANGE
Audi – S8	[2001]
Kenworth – Heavy Truck	[2007–2008]
Porsche – 911	[1999–2008]
Porsche – Boxster	[2003]

MAKE / MODEL	YEAR RANGE
Volkswagen – Models with male threads on exp. tank	[1975–1993]
Volvo trucks – V670	[2005]
Volvo trucks – VN430	[2005]



#FZ25 Tank Adapter

- M47 x 3 Threads

MAKE / MODEL	YEAR RANGE
Autocars – Trucks	[2001–2016]
BMW – 330e	[2017–2018]
BMW – 430i	[2017–2019]
BMW – 530e	[2017–2018]
BMW – 740e	[2017–2018]
BMW – i3	[2014–2018]
BMW – i8	[2014–2018]
BMW – X5 xdrive 40e	[2017–2018]

MAKE / MODEL	YEAR RANGE
BMW – V8 Twin (turbo) Intercooler Coolant Reservoir	[2008–2017]
Ferrari – 350 series with threaded tank	All Applicable
Ferrari – 450 series with threaded tank	All Applicable
Ferrari – 550 series with threaded tank	All Applicable
Fiat – 500	[2012–2016]
Jeep – All Models	[1987–1990]

MAKE / MODEL	YEAR RANGE
Land Rover – Freelander	[2002–2004]
Mini – Mini Cooper	[2007–2016]
RAM Trucks – Promaster Van	[2014–2018]
Saab – 9000	[1986–1998]
Sterling – All Models	[1987–1991]
Volvo – Passenger Vehicles (with threaded neck)	[1978–2006]
Volvo – Volvo Trucks (M47 x 3 threads)	[1978–2006]



**#FZ32A
Tank Adapter**

- M52 x 2.5 Threads



**#FZ36
Cap Adapter**

- M52 x 2.5 Threads



MAKE / MODEL

YEAR RANGE

Aston Martin – DB9	[2016]
Aston Martin – Rapide	[2016]
Aston Martin – Rapide S	[2016]
Aston Martin – Vanquish	[2016]
Aston Martin – Vantage	[2016]
Dodge – Dart 2.4L	[2016]
Ford – Crown Victoria	[1994–2003]
Ford – E-Series van	[1995–2003]
Ford – Edge	[2013–2015]
Ford – Escape	[2007–2012]
Ford – Excursion	[2000–2004]
Ford – Expedition	[2003–2016]
Ford – Explorer	[2002–2018]
Ford – F-150	[2004–2014]
Ford – F-250	[2002–2016]
Ford – F-250 6.7L Power Stroke	[2016–2018]
Ford – Five Hundred	[2005]
Ford – Freestyle	[2005]

MAKE / MODEL

YEAR RANGE

Ford – Flex	[2011]
Ford – Focus	[2006]
Ford – Fusion	[2010–2011]
Ford – Mustang	[1996–2014]
Ford – Taurus	[1996–2006]
Ford – Thunderbird	[1993–2005]
Ford – Windstar	[2002–2003]
Freightliner – Cascadia	[2008]
Freightliner – Columbia	[2008]
International – 6.4L Diesel	[2012]
International – Navistar VT 365	[2007]
International – with 466 engine	[1994–2002]
Jaguar – F-Type	[2016]
Jaguar – S Type	[2003–2008]
Jaguar – X Type	[2003–2008]
Jaguar – XF	[2009–2015]
Jaguar – XJ	[2003–2015]
Jaguar – XK	[2003–2013]

MAKE / MODEL

YEAR RANGE

Land Rover – Discovery Sport	[2016]
Land Rover – LR3	[2005–2014]
Land Rover – Range Rover	[2016]
Land Rover – Range Rover Sport	[2006–2016]
Lincoln – Mark VIII	[1993–1998]
Lincoln – Navigator	[1998]
Lincoln – Towncar	[1993–1999]
Mercedes – ML 320	[1998–2005]
Mercedes – ML 430	[1998–2005]
Mercury – Cougar	[1995]
Mercury – Crown Victoria	[1993–2003]
Mercury – Grand Marquis	[1993–2003]
Mercury – Sable	[1996–2003]
Nissan – Armada	[2005–2015]
Nissan – Titan	[2004–2015]



#FZ35A Tank Adapter

- M52 x 2.5 Threads



#FZ36 Cap Adapter

- M52 x 2.5 Threads



MAKE / MODEL	YEAR RANGE
Aston Martin – DB9	[2016]
Aston Martin – Rapide	[2016]
Aston Martin – Rapide S	[2016]
Aston Martin – Vanquish	[2016]
Aston Martin – Vantage	[2016]
Buick – Encore	[2014]
Buick – Lacrosse	[2011–2014]
Buick – Roadmaster	[1994–1996]
Buick – Skylark	[1992–1998]
Cadillac – ATS	[2014–2015]
Cadillac – CTS	[2003–2015]
Cadillac – CTS4	[2016]
Cadillac – ELR Coupe	[2014]
Cadillac – Escalade	[1999–2015]
Cadillac – Escalade ESV	[2014–2015]
Cadillac – Fleetwood	[1994–1996]
Cadillac – Seville	[1998–2004]
Cadillac – SRX	[2014–2015]
Cadillac – XTS Sedan	[2014–2015]
Chevrolet – Aveo	[2008–2011]
Chevrolet – Beretta	[1992–1996]
Chevrolet – Camaro	[1999–2015]
Chevrolet – Caprice	[1995–1996]
Chevrolet – Cavalier	[1995–2005]
Chevrolet – Cobalt	[2005–2010]
Chevrolet – Corsica	[1992–1996]
Chevrolet – Corvette	[1999–2015]
Chevrolet – Cruze	[2011–2018]
Chevrolet – Express	[2010–2015]
Chevrolet – Impala SS	[1994–1996]

MAKE / MODEL	YEAR RANGE
Chevrolet – Malibu	[1997–2018]
Chevrolet – Metro	[1999–2001]
Chevrolet – Prizm	[1999–2002]
Chevrolet – Silverado 1500	[1999–2018]
Chevrolet – Silverado 2500 (gas)	[1999–2016]
Chevrolet – Suburban	[2000–2015]
Chevrolet – Tahoe	[1999–2015]
Chevrolet – Tracker	[1999–2004]
Chevrolet – Trailblazer	[2001–2009]
Chevrolet – Trax	[2015]
Chevrolet – Van	[2007–2011]
Chrysler – 200	[2015]
Chrysler – Pacifica	[2017]
Freightliner – Diesel truck	[2004–2004]
GMC – Envoy	[2002–2002]
GMC – Sierra	[2014]
GMC – Sierra 1500	[1999–2015]
GMC – Sierra 2500	[1999–2003]
GMC – Sierra 2500 HD	[2015]
GMC – Sierra 3500	[2014]
GMC – Sierra 3500 HD Denali	[2014]
GMC – Sierra 3500 6.6L Duramax DSL	[2016]
GMC – Terrain	[2014]
GMC – Terrain Denali	[2014]
GMC – Yukon	[1999–2015]
Jaguar – F-Type	[2016]
Jaguar – S Type	[2003–2008]
Jaguar – X Type	[2003–2008]

MAKE / MODEL	YEAR RANGE
Jaguar – XF	[2009–2015]
Jaguar – XJ	[2003–2015]
Jaguar – XK	[2003–2013]
Jeep – Grand Cherokee	[2016–2017]
Land Rover – Discovery Sport	[2016]
Land Rover – Freelander	[2005]
Land Rover – LR3	[2005–2014]
Land Rover – Range Rover	[2016]
Land Rover – Range Rover Sport	[2006–2016]
Oldsmobile – Achieva	[1992–1998]
Oldsmobile – Alero	[1999]
Oldsmobile – Aurora	[1995–1999]
Oldsmobile – Cutlass	[1997–1998]
Oldsmobile – Intrigue	[1999–2000]
Pontiac – G6	[2005–2008]
Pontiac – Grand Am	[1992–1999]
Pontiac – Grand Prix	[2006]
Pontiac – Sunfire	[1995–1999]
RAM Trucks – 1500 3.0L EcoDiesel	[2014–2017]
RAM Trucks – 2500 6.7L Cummins	[2013–2018]
RAM Trucks – 3500 6.7L Cummins	[2013–2018]
Saab – 93	[2003–2004]
Saturn – All Models	[1990–2005]



#FZ41
Tank Adapter

- M63 x 3 Threads

MAKE / MODEL	YEAR RANGE
Audi – A3	[2006–2018]
Audi – A4	[1996–2018]
Audi – A5	[2008–2018]
Audi – A6	[1998–2018]
Audi – A7	[2012–2018]
Audi – A8	[2006–2018]
Audi – Allroad Quattro	[2001–2003]
Audi – Q3	[2016–2018]
Audi – Q5	[2009–2018]
Audi – Q7	[2007–2018]

MAKE / MODEL	YEAR RANGE
Audi – S3	[2016–2018]
Audi – S4	[2000–2018]
Audi – S5	[2008–2018]
Audi – S7	[2016–2018]
Audi – TT	[2000–2015]
Lamborghini – Gallardo	[2006–2013]
Porsche – 911 (991 body)	[2012–2015]
Porsche – Cayenne	[2004–2013]
Volkswagen – Atlas	[2018]
Volkswagen – Beetle	[1999–2015]

MAKE / MODEL	YEAR RANGE
Volkswagen – CC	[2009–2015]
Volkswagen – EOS	[2007–2015]
Volkswagen – Golf	[1999–2018]
Volkswagen – GTI	[2008–2016]
Volkswagen – Jetta	[2015–2018]
Volkswagen – Passat	[1998–2018]
Volkswagen – Rabbit	[2006–2009]
Volkswagen – Tiguan	[2009–2018]
Volkswagen – Touareg	[2004–2015]



 **#FZ47**
Tank Adapter

- M49 x 2.5 buttress Threads

MAKE / MODEL	YEAR RANGE
Ford – C-Max	[2014–2016]
Ford – EcoSport	[2018–2018]
Ford – Edge	[2013–2018]
Ford – Escape	[2013–2018]
Ford – Expedition	[2015–2018]
Ford – F-150	[2015–2018]
Ford – Fiesta	[2011–2018]
Ford – Focus	[2012–2018]
Ford – Fusion	[2013–2018]
Ford – Mustang	[2016–2018]

MAKE / MODEL	YEAR RANGE
Ford – Transit 150 3.5L (turbo)	[2015–2016]
Ford – Transit 150 3.2L (Diesel)	[2015]
Ford – Transit 250 3.7L	[2015]
Ford – Transit Connect	[2014–2015]
Land Rover – LR2	[2007–2015]
Land Rover – Range Rover Evoque	[2012–2017]
Mazda – 3	[2004–2013]
Mazda – 6	[2004–2009]
Volvo – S40	[2004–2010]
Volvo – S60	[2016–2019]

MAKE / MODEL	YEAR RANGE
Volvo – S80	[2008–2016]
Volvo – S90	[2016–2019]
Volvo – V50	[2005–2010]
Volvo – V60	[2010–2019]
Volvo – V90	[2016–2019]
Volvo – XC40	[2019]
Volvo – XC60	[2010–2019]
Volvo – XC70	[2008–2016]
Volvo – XC90	[2016–2019]



#FZ55 Tank Adapter

- M46 x 2.5mm Threads



MAKE / MODEL

YEAR RANGE

Dodge – Sprinter	[2007–2009]
Mercedes – Sprinter	[2010–2019]
Mercedes - Metris	[2018-2019]



#M034919 Tank Adapter

- M62 x 4mm Threads
- Applicable to 1996-2019 models
- For ML models [1998-2005], see #FZ35A

MAKE / MODEL

YEAR RANGE

Mercedes – AMG	All Applicable
Mercedes – C class	All Applicable
Mercedes – CL class	All Applicable
Mercedes – CLK class	All Applicable

MAKE / MODEL

YEAR RANGE

Mercedes – CLS class	All Applicable
Mercedes – E class	All Applicable
Mercedes – G class	All Applicable
Mercedes – ML 164	All Applicable

MAKE / MODEL

YEAR RANGE

Mercedes – R class	All Applicable
Mercedes – S class	All Applicable
Mercedes – SL class	All Applicable
Mercedes – SLK class	All Applicable





#2124 24mm Oil Filter Socket

- 3/8" Drive

MAKE / MODEL	YEAR RANGE	MAKE / MODEL	YEAR RANGE	MAKE / MODEL	YEAR RANGE
BMW – 545	[2004–2005]	BMW – Alpina B7	[2007–2008]	Dodge –Charger	[2011–2016]
BMW – 550	[2006–2010]	BMW – X5	[2004–2010]	Dodge –Durango	[2011–2016]
BMW – 645Ci	[2004–2005]	Chevrolet – Trax	[2015–2015]	Dodge –Grand Caravan	[2011–2016]
BMW – 650i	[2006–2010]	Chrysler – 200	[2011–2016]	Dodge –Journey	[2011–2016]
BMW – 745i	[2002–2005]	Chrysler – 300	[2011–2016]	Jeep – Grand Cherokee	[2011–2016]
BMW – 745Li	[2002–2005]	Chrysler – Town & Country	[2011–2016]	Jeep – Wrangler	[2012–2017]
BMW – 750i	[2006–2008]	Dodge – Avenger	[2011–2016]	Maserati – Ghibli	[2013–2013]
BMW – 750Li	[2006–2008]	Dodge –Challenger	[2011–2016]	Saturn – Astra	[2008–2009]



#2127 27mm Oil Filter Socket

- 3/8" Drive

MAKE / MODEL	YEAR RANGE	MAKE / MODEL	YEAR RANGE	MAKE / MODEL	YEAR RANGE
Kia – Sedona (6-cyl.)	[2014–2015]	Hyundai – Equus	[2011–2013]	Kia – Borrego	[2009–2012]
BMW – 535d	[2014–2015]	Hyundai – Genesis	[2008–2013]	Kia – Cadenza	[2014–2018]
BMW – 740Ld xDrive	[2015]	Hyundai – Santa Fe 3.3L	[2009]	Kia – Sedona (6-cyl.)	[2016–2018]
BMW – X5 35d xDrive	[2014–2015]	Hyundai – Sonata 3.3L	[2009]	Kia – Sorento	[2007–2018]
Fiat – 500	[2012–2013]	Hyundai – Veracruz	[2007–2013]	Mercedes – C 300 (204)	[2015]
Hyundai – Azera	[2009–2012]	Kia – Amanti	[2007–2009]	Mini – Cooper	[2007–2015]



#2132
32mm Oil Filter Socket

- 3/8" Drive

MAKE / MODEL	YEAR RANGE	MAKE / MODEL	YEAR RANGE	MAKE / MODEL	YEAR RANGE
Audi – A4	[2017]	BMW – 530i	[2017–2018]	Chevrolet – Malibu	[2007–2014]
Audi – Q3	[2015–2016]	BMW – 540i	[2017–2018]	Land Rover – Range Rover 3.0L Diesel	[2016]
Audi – S3	[2015–2016]	BMW – 740i	[2017–2018]	Maserati – Quattroporte	[2013–2014]
BMW – 230i	[2017–2018]	BMW – M240i	[2017–2018]	Saab – 9-3	[2003]
BMW – 330i	[2017–2018]	BMW – X1	[2016–2018]	Saturn – Ion	[2005]
BMW – 335d	[2009–2011]	BMW – X5 35d	[2009–2013]	Volkswagen – Golf 2.0 TDI	[2011–2016]
BMW – 340i	[2017–2018]	Chevrolet – Cobalt	[2007–2010]	Volkswagen – Jetta 2.0 TDI	[2011–2016]
BMW – 430i	[2017–2018]	Chevrolet – Impala	[2014]		



#2136
36mm Oil Filter Socket

- 3/8" Drive

MAKE / MODEL	YEAR RANGE	MAKE / MODEL	YEAR RANGE	MAKE / MODEL	YEAR RANGE
Audi – A6 3.0 (turbo)	[2014–2016]	Ford – F-250 6.0L (turbo diesel)	[2004]	Volkswagen – Corrado	
Audi – Q7	[2007–2016]	Ford – F-350 6.0L (turbo diesel)	[2004]	Volkswagen – Eurovan	
BMW – M52 Engine	[1994–2000]	Mercedes – E300 diesel	[1996–1999]	Volkswagen – R32	[2004]
BMW – M54 Engine	[2000–2005]	Mini – Cooper	[2002–2006]	Volkswagen – Touareg	[2002–]
BMW – M60 Engine	[1992–1996]	Porsche – 911	[2009–2016]	Volvo – 3.0L	[2007–2014]
BMW – M62 Engine	[1994–2005]	Porsche – Boxster	[2009–2016]	Volvo – 3.2L engine	[2007–2014]
BMW – M70 Engine	[1988–1996]	Porsche – Cayenne	[2009–2016]		
BMW – M73 Engine	[1993–2002]	Porsche – Panamera	[2009–2016]		



#2175
74.5mm Oil Filter Wrench

- 14 Flat, 22mm Hex Drive

California Residents: Proposition 65
WARNING. See page 125 for info.

MAKE / MODEL	YEAR RANGE	MAKE / MODEL	YEAR RANGE	MAKE / MODEL	YEAR RANGE
Audi – 4000	All Applicable	Mercedes – E 250 2.1L (turbo diesel)	[2014–2016]	Porsche – 924	All Applicable
Audi – 5000	All Applicable	Mercedes – GLK 250 2.1L (turbo diesel)	[2014]	Porsche – 944	All Applicable
BMW – M44 engine	All Applicable	Mercedes – ML 250 2.1L (turbo diesel)	[2015]	Volkswagen – Beetle	[2005–2014]
Dodge – Sprinter (gas engine)	[2003–2006]	Mercedes – Sprinter 2.1L (turbo diesel)	[2014–2016]	Volkswagen – Dasher	All Applicable
Mercedes – C 350	[2015]			Volkswagen – Fox	All Applicable
Mercedes – C 400	[2015]			Volkswagen – Golf	All Applicable
				Volkswagen – Jetta	[2005–2014]
				Volkswagen – Scirocco	All Applicable
				Volkswagen – Rabbit	[1975–1984]



#BM1276
76mm Oil Filter Wrench

- 3/8" Drive

MAKE / MODEL	YEAR RANGE
BMW – i3 "Range Extender"	[2014-2018]
BMW – Motorcycles	[2007-2016]
Mercedes – Factory Oil Filter with 12 flutes	



#HD1674
Oil Filter Wrench for Harley-Davidson

MAKE / MODEL	YEAR RANGE
Harley-Davidson Motorcycles	[1980-2016]

California Residents: Proposition 65
WARNING. See page 125 for info.



 **#JA19015**
90mm Oil Filter Wrench

- 15 Flats, 3/8" Drive

MAKE / MODEL	YEAR RANGE	MAKE / MODEL	YEAR RANGE
Jaguar – XF	[2010–2018]	Land Rover – LR4	[2010–2018]
Jaguar – XFR	[2010–2016]	Land Rover – Range Rover	[2010–2018]
Jaguar – XJ	[2010–2018]	Land Rover – Range Rover Sport	[2010–2018]
Jaguar – XJL	[2010–2016]		
Jaguar – XK	[2010–2016]		
Jaguar – XKR	[2010–2016]		



#JAS6514
65mm Oil Filter Wrench

- 14 Flat, 3/8" Drive

MAKE / MODEL	YEAR RANGE	MAKE / MODEL	YEAR RANGE	MAKE / MODEL	YEAR RANGE
Honda – All Models (except S2000)	[1990–2018]	Mazda-3	[2012–2018]	Nissan – Juke	[2011–2018]
Infiniti – M35	[2004–2007]	Mazda-6	[2014–2018]	Nissan – Maxima	[1994–2018]
Infiniti – M45	[2004–2007]	Mazda CX-3	[2016–2018]	Nissan – Murano	[2002–2018]
Jaguar – F-Pace	[2017]	Mazda CX-5	[2013–2018]	Nissan – Pathfinder	[1995–2018]
Jaguar – XE	[2017]	Mazda MX-5 Miata	[2016–2018]	Nissan – Quest	[2006–2018]
Jaguar – XF	[2017]	Nissan – 350Z	[2002–2009]	Nissan – Rouge	[2008–2018]
Kawasaki – Motorcycle	[1990–2009]	Nissan – 370Z	[2010–2018]	Nissan – Sentra	[2001–2018]
Land Rover – Range Rover Evoque	[2018]	Nissan – Altima	[1997–2018]	Nissan – Titan	[2003–2018]
		Nissan – Armada	[2004–2018]	Nissan – Versa	[2006–2018]
		Nissan – Cube	[2009–2014]	Nissan – Xterra	[2002–2016]
		Nissan – Frontier	[1997–2018]	Yamaha – Motorcycle	[1990–2009]
		Nissan – GT-R	[2008–2018]		



M0219

74mm Oil Filter Wrench

- 14 Flat, 22mm Hex Drive

California Residents: Proposition 65
WARNING. See page 125 for info.

MAKE / MODEL	YEAR RANGE
Audi – A4 2.0 (turbo)	[2009–2016]
Audi – Q5 2.0 (turbo)	[2012–2016]
BMW Motorcycle – F650	All Applicable
BMW Motorcycle – F800	All Applicable
BMW Motorcycle – K75	All Applicable
BMW Motorcycle – K100	All Applicable
BMW Motorcycle – K1100	All Applicable
BMW Motorcycle – K1200GT	[2003–2004]
BMW Motorcycle – K1200LT	All Applicable
BMW Motorcycle – K1200R	All Applicable
BMW Motorcycle – K1200RS	[1996–2004]
BMW Motorcycle – K1200S	All Applicable
BMW Motorcycle – K1300	All Applicable
BMW Motorcycle – R850	All Applicable
BMW Motorcycle – R1100	All Applicable
BMW Motorcycle – R1150	All Applicable
BMW Motorcycle – R1200C	All Applicable
BMW Motorcycle – R1200CL	All Applicable
BMW Motorcycle – R1200GSW	[2013–2014]
BMW Motorcycle – S1000RR	All Applicable
Dodge – Avenger	[2012–2013]
Dodge – Caliber	[2012]
Dodge – Dart	[2013]
Dodge – Sprinter (gas engines)	[2003–2012]
Ford – Escape	[2006–2008]
Ford – Fusion	[2006–2008]

MAKE / MODEL	YEAR RANGE
Ford – Focus	[2004–2007]
Jaguar – XE (2.0L Turbo)	[2017]
Jaguar – XF (2.0L Turbo)	[2017]
Land Rover – Range Rover Evoque	[2013–2017]
Mazda – 3	[2004–2009]
Mazda – 5	[2006–2011]
Mazda – 6	[2003–2009]
Mazda – CX-7	[2007–2009]
Mazda – Mazdaspeed 3	[2007–2009]
Mazda – Mazdaspeed 6	[2006–2007]
Mercedes – M104	[1989–1999]
Mercedes – M119 engine	[1989–1999]
Mercedes – M111 engine	[1992–2003]
Mercedes – M112 engine	[1998–2006]
Mercedes – M113 engine	[1997–2010]
Mercedes – M120 engine	[1991–2002]
Mercedes – M137 engine	[1998–2002]
Mercedes – M155 engine	[2004–2006]
Mercedes – M272 engine	[2005–2015]
Mercedes – M273 engine	[2006–2015]
Mercedes – M275 engine	[2003–2014]
Mercedes – M276 engine	[2010–2015]
Mercedes – M285 engine	[2003–2012]
Mercedes – Sprinter (gas)	[1998–2015]
Porsche – 911	[1999–2008]
Porsche – Boxster	[1997–2008]

MAKE / MODEL	YEAR RANGE
Porsche – Caymen	[2005–2008]
Toyota – 4Runner	[1985–2002]
Toyota – Avalon	[1995–2002]
Toyota – Camry [V6]	[1988–2004]
Toyota – Highlander [V6]	[2001–2010]
Toyota – Previa	[1991–1997]
Toyota – Sienna	[1998–2007]
Toyota – Solara [V6]	[1999–2009]
Toyota – Supra	[1979–1998]
Toyota – T100	[1993–1998]
Toyota – Tacoma	[1995–2012]
Toyota – Tundra	[2000–2004]
Volkswagen – Beetle 2.5L	[2005–2014]
Volkswagen – CC	[2009–2013]
Volkswagen – EOS	[2009–2013]
Volkswagen – Golf	[1999–2005]
Volkswagen – GTI	[2008]
Volkswagen – Jetta 1.4 (turbo)	[2016]
Volkswagen – Tiguan	[2009–2016]



#MO284
84mm Oil Filter Wrench

- 14 Flat, 22mm Hex Drive

 California Residents: Proposition 65
WARNING. See page 125 for info.

MAKE / MODEL	YEAR RANGE
Dodge – Sprinter	[2007–2009]
Freightliner – Sprinter	[2007–2018]
Jeep – Grand Cherokee	[2007–2008]
Mercedes – E 320 (BLUETEC)	[2007–2009]

MAKE / MODEL	YEAR RANGE
Mercedes – E 350 (BLUETEC)	[2011–2015]
Mercedes – GL 320 (BLUETEC)	[2009]
Mercedes – GL 350 (BLUETEC)	[2010–2015]
Mercedes – ML 320 (BLUETEC)	[2009]

MAKE / MODEL	YEAR RANGE
Mercedes – ML 350 (BLUETEC)	[2010–2015]
Mercedes – R 320 (BLUETEC)	[2009]
Mercedes – R 350 (BLUETEC)	[2010–2015]
Mercedes – S 350 (BLUETEC)	[2012–2015]
Mercedes – Sprinter	[2007–2017]



#SU8015
80mm Oil Filter Wrench

- 15 Flats, 3/8" Drive

MAKE / MODEL	YEAR RANGE
Hyundai – Accent	[1995–2013]
Hyundai – Elantra	[1992–2013]
Hyundai – Excel	[1986–1994]
Hyundai – Genesis Coupe 2.0L	[2008–2012]
Hyundai – S Coupe	[1992–1994]
Hyundai – Santa Fe 2.4L	[2000]
Hyundai – Santa Fe 2.7L	[2000–2009]
Hyundai – Sonata	[1992–2012]
Hyundai – Tiburon	[2001–2008]
Hyundai – Tucson	[2004–2012]
Hyundai – Veloster	[2011–2013]
Hyundai – XG300	[2000–2005]

MAKE / MODEL	YEAR RANGE
Hyundai – XG350	[2000–2005]
Kia – Amanti	[2004–2006]
Kia – Forte	[2010–2018]
Kia – Niro	[2017–2018]
Kia – Optima	[2001–2018]
Kia – Rio	[2006–2012]
Kia – Rondo	[2007–2009]
Kia – Sorento	[2003–2018]
Kia – Soul	[2010–2018]
Kia – Spectra	[2004–2009]
Kia – Sportage	[2005–2018]
Nissan – Sentra	[1999]

MAKE / MODEL	YEAR RANGE
Scion – FR-S	[2013–2016]
Subaru – BRZ	[2013–2018]
Subaru – Forester	[2011–2016]
Subaru – Impreza WRX	[2016]
Subaru – Legacy (6-cyl.)	All Applicable
Subaru – Outback (6-cyl.)	All Applicable
Subaru – Tribeca	All Applicable
Subaru – WRX	[2015–2018]
Subaru – All 6-cyl. Engines	All Applicable



#TOY640
64mm Oil Filter Wrench

- 14 Flats, 24mm Hex Drive

California Residents: Proposition 65
WARNING. See page 125 for info.

MAKE / MODEL	YEAR RANGE
Lexus – CT 200h	[2011–2016]
Lexus – ES 350	[2007–2018]
Lexus – GS 300	[2006–2018]
Lexus – GS 350	[2007–2018]
Lexus – GS 450h	[2007–2018]
Lexus – GS 460	[2008–2011]
Lexus – GX 460	[2010–2018]
Lexus – HS 250h	[2010–2013]
Lexus – IS 250	[2006–2016]
Lexus – IS 250 C	[2010–2016]
Lexus – IS 350	[2006–2016]
Lexus – IS 350 C	[2010–2016]
Lexus – IS F	[2008–2014]
Lexus – LS 460	[2007–2016]

MAKE / MODEL	YEAR RANGE
Lexus – LS 600h	[2008–2016]
Lexus – LX 570	[2008–2018]
Lexus – RX 350	[2007–2018]
Lexus – RX 450h	[2010–2018]
Scion – tC	[2005–2016]
Scion – xA	[2004–2006]
Scion – xB	[2004–2016]
Scion – xD	[2008–2013]
Toyota – 4Runner	[2010–2019]
Toyota – Avalon	[2005–2019]
Toyota – Camry	[1983–2019]
Toyota – Corolla	[1983–2019]
Toyota – Echo	[2000–2005]
Toyota – FJ Cruiser	[2007–2014]

MAKE / MODEL	YEAR RANGE
Toyota – Highlander	[2001–2019]
Toyota – Matrix	[2003–2014]
Toyota – MR2	[1985–2005]
Toyota – Paseo	[1992–1997]
Toyota – Prius	[2001–2019]
Toyota – RAV4	[1996–2019]
Toyota – Sequoia	[2009–2019]
Toyota – Sienna	[2007–2019]
Toyota – Solara	[1999–2008]
Toyota – Tundra	[2007–2019]
Toyota – Venza	[2009–2016]
Toyota – Yaris	[2006–2019]



#TOY647LG
64mm
Oil Filter Wrench

- 14 Flats, 3/8" Drive

MAKE / MODEL	YEAR RANGE
Toyota – V6 and V8 models	[2005–2019]





#TOY730
73mm Oil Filter Wrench

- 14 Flat, 3/8" Drive

California Residents: Proposition 65
WARNING. See page 125 for info.

MAKE / MODEL	YEAR RANGE
Lexus – ES 250	[1990–1991]
Lexus – ES 300	[1992–2003]
Lexus – ES 300h	[2013]
Lexus – ES 330	[2004–2006]
Lexus – GS 300	[1993–2005]
Lexus – GS 400	[1998–2000]
Lexus – GS 430	[2001–2004]
Lexus – GX 470	[2004–2009]
Lexus – IS 300	[2001–2005]
Lexus – LS 400	[1990–2000]

MAKE / MODEL	YEAR RANGE
Lexus – LS 430	[2001–2006]
Lexus – LX 450	[1996–1997]
Lexus – LX 470	[1998–2007]
Lexus – RX 300	[1999–2003]
Lexus – RX 330	[2004–2006]
Lexus – RX 400h	[2006–2008]
Lexus – SC 300	[1992–2000]
Lexus – SC 400	[1992–2000]
Lexus – SC 430	[2002–2010]
Toyota – 4Runner 4.0L & 4.7L	[2003–2010]

MAKE / MODEL	YEAR RANGE
Toyota – FJ Cruiser 4.0L	[2007–2010]
Toyota – Land Cruiser	[1993–2007]
Toyota – Sequoia	[2001–2009]
Toyota – Tacoma	[2005–2013]
Toyota – Tundra	[2000–2010]



#V410
86.5mm Oil Filter Wrench

- 16 Flat, 22mm Hex Drive

California Residents: Proposition 65
WARNING. See page 125 for info.

MAKE / MODEL	YEAR RANGE
BMW – [N20 engine]	[2011–2017]
BMW – [N52 engine]	[2006–2012]

MAKE / MODEL	YEAR RANGE
BMW – [N54 engine]	[2006–2012]
BMW – [N55 engine]	[2011–2017]

MAKE / MODEL	YEAR RANGE
Volvo – All models (exc. 2005 40 & 50 Series)	[1999–2006]



#VB414
Oil Filter Wrench

- 16 Flat, 22mm Hex Drive

California Residents: Proposition 65
WARNING. See page 125 for info.

MAKE / MODEL	YEAR RANGE
Volvo – S60	[2015–2019]
Volvo 2.0L – S80	[2015–2019]

MAKE / MODEL	YEAR RANGE
Volvo 2.0L – V60	[2015–2019]
Volvo 2.0L – XC60	[2015–2019]

MAKE / MODEL	YEAR RANGE
Volvo 2.0L – XC70	[2015–2019]



WARNING:

These products can expose you to chemicals including Hexavalent Chromate, which are known to the State of California to cause cancer and birth defects or other reproductive harm.

Hexavalent Chromate

AST Tools with this warning:

#MC240	Window Wrench	#JLR0197	Fuel Injector Puller
#MC114	Serpentine Belt Wrenches	#MB164251	Fuel Pump Wrench
#SU200T	Camshaft Pulley Holder	#3307	Fuel Pump Wrench
#3217	Fuel Sender Spanner		



WARNING:

These products can expose you to chemicals including Bisphenol A (BpA), which is known to the State of California to cause birth defects or other reproductive harm.

BPA

AST Tools with this warning:

#OFCRY36	Engine Oil Funnel	#FUNCRY36	Funnel Adapter
#OFGMRD08	Engine Oil Funnel	#MW35	Hard Black Wedge Set



WARNING:

These products can expose you to chemicals including Lead and Nickel, which are known to the State of California to cause cancer.

Lead and Nickel

AST Tools with this warning:

#2175	Oil Filter Wrench	#TOY730	Oil Filter Wrench
#M0219	74mm Oil Filter Wrench	#VB414	Oil Filter Wrench
#M0284	84mm Oil Filter Wrench	#HD1674	Oil Filter Wrench
#TOY640	Oil Filter Wrench	#WSC15	Wire Soldering Clamp



WARNING:

These products can expose you to chemicals including Acrylonitrile & Styrene, which are known to the State of California to cause cancer and Butadiene, which is known to the State of California to cause birth defects or other reproductive harm.

ABS

AST Tools with this warning:

#OFFM202	Engine Oil Funnel	#OFH0N1033	Oil Funnel
#OFAAGM	Angled Funnel Extension	#OFSU1042	Subaru Oil Funnel
#OFH33	Funnel Extension	#OFSU42	Subaru Adapter
#OFHD35	Oil Funnel	#OFT38	Funnel Extension
#OFHD419	Oil Funnel	#OFTOY1038	Threaded Toyota Oil Funnel



WARNING:

This product can expose you to chemicals including Acrylonitrile & Styrene, which are known to the State of California to cause cancer and Bisphenol A (BpA) & Butadiene, which is known to the State of California to cause birth defects or other reproductive harm.

ABS and BPA

AST Tools with this warning:

#FUN14KIT	Oil Funnel Set
-----------	----------------



WARNING:

These products can expose you to chemicals including Nickel, which are known to the State of California to cause cancer.

Nickel

AST Tools with this warning:

#BMW2755	Intermediate Spring Tool
#BMW5585	Camshaft Bridge



WARNING:

These products can expose you to chemicals including Chromium and Lead, which are known to the State of California to cause cancer.

Chromium and Lead

AST Tools with this warning:

#201	Stud Puller Set	200-8	Stud Remover	200-7/16	Stud Remover
#201-7	Stud Puller Set	200-10	Stud Remover	200-1/2	Stud Remover
#202	Stud Puller Set	200-12	Stud Remover	200-9/16	Stud Remover
#203	Stud Puller Set	200-1/4	Stud Remover	200-5/8	Stud Remover
200-6	Stud Remover	200-5/16	Stud Remover		
200-7	Stud Remover	200-3/8	Stud Remover		



TOOL #	PAGE #
60	102
70	102
80	102
100	102
120	102
200-6	102
200-7	42, 102
200-8	102
200-10	102
200-12	102
200-1/4	102
200-5/16	102
200-3/8	102
200-7/16	102
200-1/2	102
200-9/16	102
200-5/8	102
201	103
202	103
203	103
250	102
312	102
375	102
437	102
500	102
562	102
625	102
100-30A	17, 43, 50, 98
201-7	42, 103
1018	28
2017SACP	76, 80
2101	41, 51, 69, 92
2124	22, 31, 41, 92, 117
2127	10, 22, 30, 46, 51, 92, 117
2132	41, 48, 69, 92, 118
2136	30, 41, 51, 56, 69, 92, 118
2175	22, 41, 51, 69, 76, 93, 119
3035	9, 57, 101, 107

TOOL #	PAGE #
3200T-6	72
3200X-4	72
3200X-8	72
3206	54, 82, 105
3217	66
3242	61
3299A	61
3307	66
3316	57, 105
3344A	57, 105
3359	59
3366	60
3391	64
3424	71, 96
3428	59
3462	70, 96
3810	82, 104
3900	83, 98
6300	71, 96
6300T-50	10, 50, 99
6300X-12	71, 96
6300X-14	71, 96
6300X-16	71, 77, 96
6300XL-10	71, 96
6300XL-14	71, 96
6300XL-8	71, 96
6355X-14	70, 97
6500-14	72, 97
6500-17	72, 97
6500T-100	50, 77, 97
6500TL-80	42, 97
6500TPT-100	50, 97
6500X-18	72, 97
6500X-24	72, 97
6500X-30	72, 97
6500X-32	72, 97
6506	72, 97
6814TDI	59
7200	17, 24, 62, 83
7200-4	24, 32

TOOL #	PAGE #
8010	28
8012	28
8013	28
8014	28
8016	22
8021	28, 32
8022	32
8023	28
8024	28
8026	13, 15
8027	32
8028	20
8032	35
23236	41, 70, 92
ALSJ05	82
ALT34018	10, 50, 56, 70, 99
ATF16DSG	65, 87
ATF17CVT	65, 87
ATF101	25, 87
ATF102	41, 87
ATF103	65, 87
ATF104	65, 87
ATF105	44, 65, 87
ATF108V	56, 87
ATF125NIS	14, 87
ATF129	54, 87
ATF175GM	32, 87
ATF180	14, 87
ATFBASIC	14, 41, 76, 83, 86, 107
AFTDRUMONLY	86
ATFEURO8	84
ATFFORD	25, 85
ATFMB	54, 85
ATFMB725	54
ATFSET9	84
ATFSET15	84
ATFSU100	10, 20, 44, 87
ATFSU118	20, 87
ATFTOY118	16, 87
ATFVW5	65, 85

TOOL #	PAGE #
AU40178	68, 95
BFLT60	30, 43, 99
BM1276	40, 92, 106
BMW0062	34
BMW345	34, 49, 110
BMW350	34, 110
BMW377	42, 99
BMW400-1	38
BMW432	43
BMW2026	38
BMW2510	39
BMW2755	37
BMW3028	37
BMW400	38
BMW4053-1	43
BMW4053-2	43
BMW4622	35
BMW5254	38
BMW5346	34
BMW5532	35
BMW5585	37
BMW6119F	35
BMW6208	36
BMW6222	38
BMW7080SAC	35
BMW8390	35
BMW9054	36
BMW9235	38
BMW10160	43, 50, 98
BMW11845	43, 100
BMW11850	36, 98
BMW11860	36, 98
BMW124052	34
BMW124057	34
BMW575190	38
BMWMC280	36
CM3021	74
CM369	74
CP2015	80
CRY323	24, 95
CRY933	24, 95
CVB15	17, 39, 55

TOOL #	PAGE #
EU2009	83
EU2011	83
EU2090	56, 99
F20T	27, 47
F1248	11, 27
F1616-376B	26
F1616-1552	26
F1616T	26
F16393	26
FM2303	11, 27
FM2330	11, 27
FUN14EURO	40, 53, 69, 91
FUN14KIT	90
FUNCRY36	22, 89
FZ22	56, 67, 77, 112
FZ25	23, 34, 49, 56, 77, 108, 112
FZ32A	13, 25, 49, 52, 77, 113
FZ35A	23, 25, 32, 77, 114
FZ36	13, 25, 32, 49, 52, 77, 113, 114
FZ41	67, 115
FZ47	11, 25, 49, 56, 115
FZ55	23, 77, 116
FZ148	17, 108, 111
FZ163	67
FZ13818	8, 11, 17, 19, 32, 106, 111
GM140	31
GM245	19, 31
H985-19	99
H2223LGT-30	42, 50, 70, 99
H2587	60
H2760	40, 51
H2850-E24	77, 99
HD1674	94, 106, 119
HO10PT	9, 99
HON1419	8
HON37517	8
HONBC26	8
HTLP100	75

TOOL #	PAGE #
JA19015	48, 94, 120
JAS6514	9, 12, 14, 48, 93, 106, 120
JLR20T	47
JLR0197	49
JLR5008	47
JLR5037	48
JLR5038	48
JLR9899	49
M17WLS	50, 100
M17XLWS	50, 100
M0219	12, 15, 22, 30, 40, 48, 51, 69, 93, 106, 121
M0284	22, 51, 76, 93, 122
M0333	54, 105
M0721	53, 95
M820	23, 50, 76, 100
M1020	23, 76, 100
M1620	51
M2000CP	80
M2010ACP	80
M2039	50
M7226	49, 53, 95
M8160	50, 98, 104
M21250	53, 95
M27161	54
M034919	52, 116
M0E24	50, 100
MB4517	51
MB164251	52
MC100	46
MC240	43
MC560	43
MC1216SET	45
MC1400	45
MC1400-1	44
MC1800	45
MC9570	46
MC11419	46
MCB4648	44



TOOL #	PAGE #
MSP1412	13, 20, 30, 42, 55, 100
MVW2050F	51, 66, 80
MW34	82, 105
MW35	82, 105
N512	13, 99
OFAAGM	29, 31, 88
OFAUD1000	40, 53, 55, 68, 76, 91
OFCRY36	22, 89
OFFM2012	12, 29, 48, 88
OFGMRD08	10, 12, 29, 31, 48, 88
OFH33	9, 89
OFHD35	10, 90, 106
OFHD419	90, 106
OFHON1033	9, 12, 14, 23, 29, 48, 89
OFSU42	19, 88
OFSU1042	19, 88
OFT38	16, 89
OFTOY1038	16, 89
OFVW2013	68, 91
S40-300	101
S3054X-10	17, 54, 70, 101
S3054X-12	17, 54, 101
SCP2014	80
SP1412	13, 20, 30, 42, 55, 101
SPR0558	23, 77, 80
SPR886	24, 77, 95
SR101	103
SU070	20, 101
SU200T	18
SU250	18
SU3625	18
SU6514	19

TOOL #	PAGE #
SU7250	18
SU7500	18
SU8015	10, 19, 93, 122
SU8252	18
T4306	58
T10050	62
T10052	63
T10066	65
T10068A	64
T10100	62
T10107B	70, 101
T10115	61
T10252	62
T10355	64
T10368	61
T10389	57, 105
T10518A	57, 105
T10531	64
T40001-6	63
T40001-7	63
T40009	61
T40011	61
T40026	61
T40028	63
T40057	68
T40058	63
T40069	61
T40079	60
T40149	67
T40196	64
T40243	60
T40267	60
T40271	64
TA18	39, 67
TM1215	16, 46, 52, 108
TM1415	16, 46, 52, 108

TOOL #	PAGE #
TM12125	9, 19
TOY18B	15
TOY105	16, 101
TOY185	17
TOY200	17
TOY211	17
TOY288	16
TOY300	15, 94
TOY640	15, 22, 94, 108, 123
TOY647LG	15, 93, 123
TOY730	15, 94, 124
TOY1914	16
TSE10TP5	99, 107
V410	40, 56, 93, 124
V450	12, 30, 43, 56
V500	55
V3032	47, 55
V5720	56
VB414	56, 94, 124
VTC100	74
VW20T	58
VW87-1	60
VW87-2	60
VW133SI	66
VW4006	63
VW5220	63, 101
VW93005	39, 57, 104
VW10352	63
VW10549	68
WSC15	81, 104
WSFLC	81
WSFLCPLUS	81