

**AKRAPOVIC RACING & EVOLUTION,
RACING & EVOLUTION STREET LEGAL EXHAUST SYSTEM
for the
YAMAHA YZF R6 (2006 - 2007)**





Congratulations on purchasing an Akrapovic exhaust system. Please read these installation instructions carefully. If you have any trouble installing the system please contact your authorized dealer!

IMPORTANT INFORMATION

Exclusion of Certain Liability

1. The manufacturer, importer or dealer shall not be liable for any incidental damage including personal injury or any other damages caused by improper installation or operation of the Akrapovic exhaust system. When installing the Akrapovic exhaust system be careful that the exhaust system does not touch other parts sensitive to high temperature.
2. Akrapovic makes no representation or warranties with regard to damage caused by the improper installation, use and maintenance of the Akrapovic exhaust system. The warranty is limited to defects recognized by our technical department and to normal use, and excludes items subject to normal wear (gaskets and damping wool). The guarantee is void in case of accident, modification, improper or competition use.
3. Do not attempt to install the Akrapovic exhaust system on a motorcycle for which it was not made or tested by Akrapovic.
4. When the exhaust system gets very hot during operation, be careful not to burn yourself on the exhaust system or parts which are in direct contact with it, even when the motor is not running. Also protect other people, especially children, from the injuries mentioned above.
5. In some cases Akrapovic exhaust system kits contain chemical products (ceramic anti-seizing grease; bolt sealant). Handle with care, do not inhale or swallow. Avoid excessive contact with skin, eyes or mucous membranes. Keep out of reach of children.
6. Technical specifications of Akrapovic exhaust systems and related products subject to change without notice.

INSTALLATION INSTRUCTIONS

- | | |
|---|---|
|  | BEFORE INSTALLING CHECK SCHEMATIC OF THE EXHAUST SYSTEM! |
|  | IF ANY ITEMS IN THE AKRAPOVIC EXHAUST SYSTEM PACKAGE ARE MISSING PLEASE CONTACT YOUR AUTHORIZED DEALER. KEEP THE SCHEMATIC FOR FUTURE REFERENCE. |
|  | THESE INSTALLATION INSTRUCTIONS MUST BE READ CAREFULLY IN ORDER TO ENSURE PROPER INSTALLATION AND OPERATION OF THE AKRAPOVIC EXHAUST SYSTEM. |
|  | THE EXHAUST SYSTEM CAN BE EXTREMELY HOT. ALLOW THE MOTORCYCLE TO COOL DOWN BEFORE BEGINNING INSTALLATION. |
|  | WE ADVISE YOU TO LEAVE INSTALLATION TO A QUALIFIED SERVICEMAN. IMPROPER INSTALLATION MAY RESULT IN A SHORTER LIFETIME OF THE EXHAUST SYSTEM AND/OR DAMAGE TO THE MOTORCYCLE. |

REMOVAL OF STOCK EXHAUST SYSTEM

1. put the motorcycle on a side stand, we recommend a racing stand
2. remove the drivers seat (**Figure 1, 2**)
3. unscrew the bolts and remove the side panels at the fuel tank (**Figure 3, 4**)
4. remove the bolt which fasten the fuel tank (**Figure 5**)
5. raise and firmly prop up the fuel tank (make sure it does not drop suddenly; you could damage the fuel tank) (**Figure 6**)
6. unscrew the bolts and plastic fasteners from the lower part of the cowling to enable to disconnect the turn signals electrical connectors (**Figure 7, 8**)
7. remove the lower part of the cowling (**Figure 9**)
8. unscrew the bolts and plastic fasteners from the upper part of the cowling and remove the cowling (**Figure 10, 11**)
9. unscrew the bolt from the muffler chassis hanging bracket (**Figure 12**)
10. unscrew the bolt from the exhaust valve heat shield and remove the shield (**Figure 13, 14**)
11. loosen and completely remove the cables from the exhaust valve (**Figure 15, 16**)
12. unscrew the bolts from the servo motor chassis hanging bracket and slightly remove the servo motor (**Figure 17**)
13. remove the harness of the exhaust valve cables (**Figure 18**)
14. completely remove the exhaust valve cables from the servo motor (from the control wheel for cable position) and from the frame (**Figure 19, 20**)
15. unscrew the bolt from the metal clamp at the muffler - link pipe joint and remove the muffler (**Figure 21, 22**)
16. unscrew the lambda sensor and adjust the wire into proper position to enable correct installation of the sensor into Akrapovic Y link pipe (**Figure 23, 24**)
17. unscrew the bolt from the lower water cooler hanging bracket; slightly remove cooler – **do not disconnect the cooling system tubes!** Make sure not to damage the cooling fins (**Figure 25**)
18. unscrew the bolts from the header tube flanges; Make sure not to damage the cooling fins (**Figure 26**)
19. unscrew the bolt from chassis hanging bracket of the primary muffler (**Figure 27**)
20. remove the stock header tubes together with the primary muffler (**Figure 28**)

INSTALLATION OF THE AKRAPOVIC RACING OR EVOLUTION EXHAUST SYSTEM

installing the servo motor:

1. replace the servo motor to the stock position (**Figure 29, 30**)

installing the header tubes:

1. set up the sleeves together with the flanges and springs; make sure they are correctly oriented and that the holes for attaching the springs line up with the loops on the header tubes; tighten the flanges; make sure not to damage the cooling fins (**Figure 31, 32**)
2. insert the header tubes properly and attach the springs; make sure not to damage the cooling fins (**Figure 33**)
3. reattach the water cooler; tighten the bolt of the hanging bracket. Make sure not to damage the cooling fins
4. make sure the header tubes are not touching the engine, coolers, other tubes, electrical installations etc.

installing the independent collectors together with the independent link pipe:

1. **for Evolution exhaust only:** slightly coat the joint of the interference crossover tube **on the collector** with Akrapovic ceramic anti-seizing grease (white tube)
2. assemble both collectors
3. **for Evolution exhaust only:** coat the interior side of the input of the titanium Y link pipe with Akrapovic ceramic anti-seizing grease (white tube)
4. slide the Akrapovic Y link pipe onto assembled collectors (**Figure 34**)
5. attach the springs
6. **for Evolution exhaust only:** coat the interior side of the input of the titanium collectors with Akrapovic ceramic anti-seizing grease (white tube)
7. make sure the collectors are correctly oriented – loops for attaching the springs must line up
8. slide the collectors onto the header tubes (**Figure 35**)
9. attach the springs (**Figure 36**)
10. make sure the collectors and the Y link pipe are not touching the frame and other parts
11. install the lambda sensor; make sure the wires are correctly positioned (**Figure 37, 38**)

installing the muffler:

1. **for Evolution exhaust only:** coat the interior side of the mufflers titanium inlet cap with Akrapovic ceramic anti-seizing grease (white tube)
2. position the muffler correctly and slide it onto the outlet side of the Y link pipe (**Figure 39**)
3. attach the springs at the Akrapovic muffler - link pipe joint (**Figure 40**)
4. turn the metal sleeve from the rubber vibration damper from behind to front (**Figure 41, 42**)
5. correctly position the carbon-fiber clamp and slide it onto the muffler, bear in mind the **left offset** of the carbon-fiber clamp viewed from the rear **WARNING:** open the clamp to slightly wider than the diameter of the outer sleeve of the muffler – do not scrape it along the muffler outer sleeve! (**Figure 43**)
6. tighten the carbon-fiber clamp onto the stock chassis hanging bracket on the frame; use the bolt, nut and washers from the Akrapovic kit (**Figure 44, 45**)
7. make sure the muffler is not touching other parts

final installation:

1. clean grease spots:
 - a. muffler – titanium outer sleeve: use a soft cloth sprayed with a multi-purpose spray lubricant (WD-40 or equivalent)
 - b. muffler – carbon-fiber outlet cap: use a soft dry cloth
 - c. RACING - stainless steel link pipe, collectors, header tubes: use a soft cloth sprayed with a contact cleaner, then wipe with a soft dry cloth
 - d. EVOLUTION - titanium link pipe, collectors, header tubes: use a soft cloth sprayed with a multi-purpose spray lubricant (WD-40 or equivalent)

Cleaning will prevent spots from burning onto the surface. Do not use aggressive chemical cleaners, because they can damage the sticker.

2. reposition the upper part of the cowling (**Figure 46**)
3. reposition the lower part of the cowling and reconnect the turn signals electrical connectors (**Figure 47, 48**)
4. tighten the bolts and plastic fasteners at the both parts of the cowling (**Figure 49, 50**)
5. replace the fuel tank (**Figure 51, 52**)
6. replace the side panels at the fuel tank (**Figure 53, 54**)
7. replace the drivers seat (**Figure 55, 56**)
8. position of the installed Akrapovic Racing or Evolution system (**Figure 57**)

Check the operation of the brakes and suspension. Make sure all the bolts are sufficiently tightened. In case the exhaust system touches the cowling or other parts repeat the adjustment of the exhaust system or contact your authorized dealer.

! IT IS NORMAL IF WHITE SMOKE COMES OUT OF THE MUFFLER ON FIRST OPERATION.

! DO NOT STAND BEHIND THE MUFFLER ON FIRST OPERATION.

! DO NOT USE AUTOMOTIVE WHEEL CLEANERS OR ANY CLEANING PRODUCTS WHICH CONTAIN ACIDIC ADDITIVES TO CLEAN AKRAPOVIC EXHAUST SYSTEMS.

MAINTENANCE OF THE AKRAPOVIC EXHAUST SYSTEM

1. Clean the titanium muffler outer sleeve with a multi-purpose spray lubricant (WD-40 or equivalent) and carbon fiber outlet cap with soft and dry cloth. Do not use aggressive chemical cleaners, because they can damage the sticker. A change in the color of the exhaust system is normal due to the high temperatures.
2. The wearing out of the muffler silencing material depends on the type of the motor and riding style. Contact your dealer/serviceman if visible changes appear on muffler's outer sleeve or the noise level is increased.
3. Periodically ensure that all the bolts and springs are sufficiently tight.

Photos:



Figure 1



Figure 2



Figure 3



Figure 4



Figure 5



Figure 6



Figure 7



Figure 8



Figure 9



Figure 10



Figure 11



Figure 12



Figure 13



Figure 14



Figure 15



Figure 16



Figure 17



Figure 18



Figure 19



Figure 20



Figure 21



Figure 22



Figure 23



Figure 24



Figure 25



Figure 26

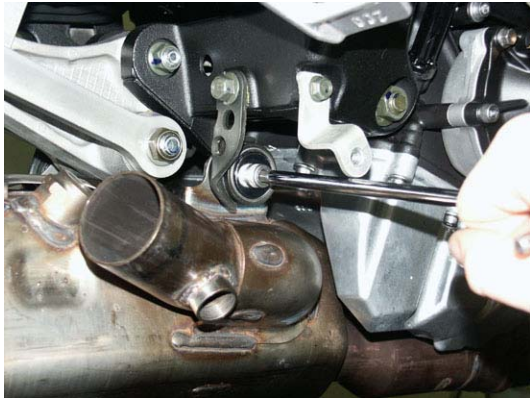

Figure 27

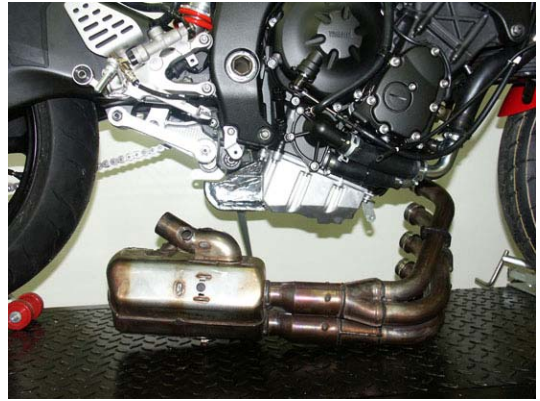

Figure 28



Figure 29



Figure 30



Figure 31



Figure 32



Figure 33



Figure 34



Figure 35

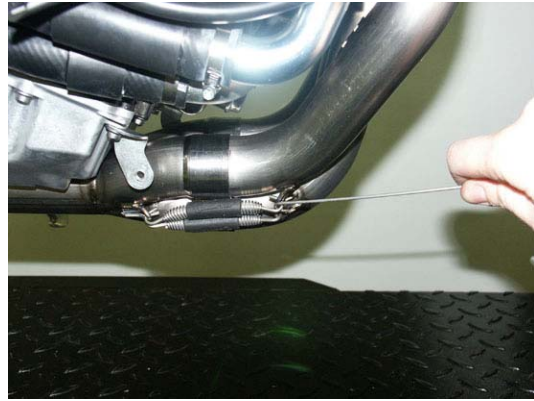

Figure 36



Figure 37



Figure 38



Figure 39



Figure 40



Figure 41



Figure 42



Figure 43



Figure 44



Figure 45



Figure 46



Figure 47



Figure 48

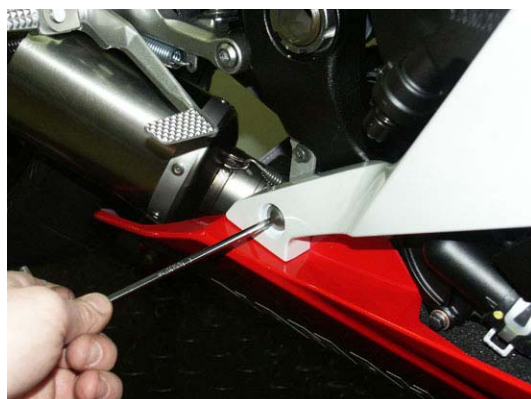

Figure 49



Figure 50



Figure 51



Figure 52



Figure 53

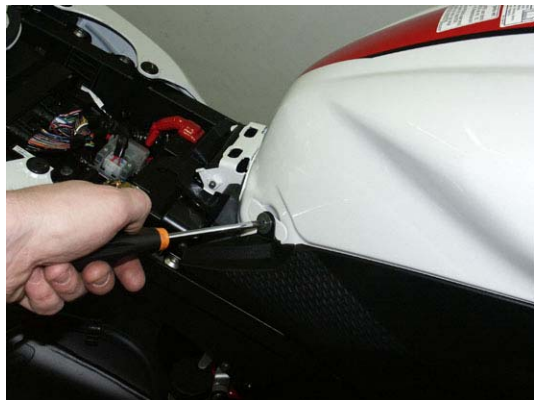

Figure 54



Figure 55



Figure 56



Figure 57

Yamaha YZF R6, Complete exhaust system/Racing line, model year:2006-2007 / OPEN

Product code:105322 (S-Y6R6-TT)
105647 (S-Y6R6-TC)

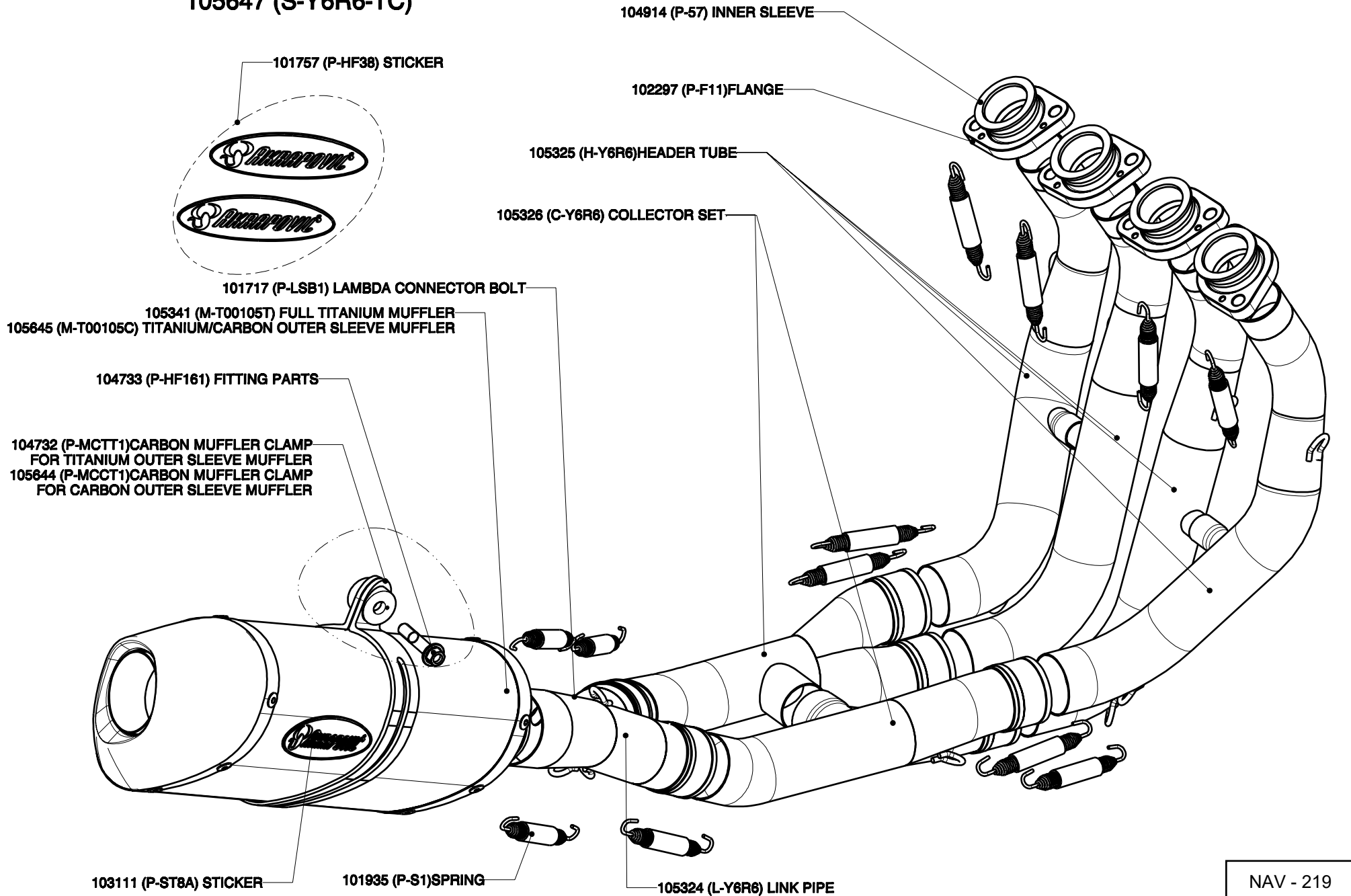

Yamaha YZF R6, Complete exhaust system/Evolution line, model year:2006-2007 / OPEN

Product code:105321 (S-Y6RFT6TL-TT)
105649 (S-Y6RFT6TL-TC)

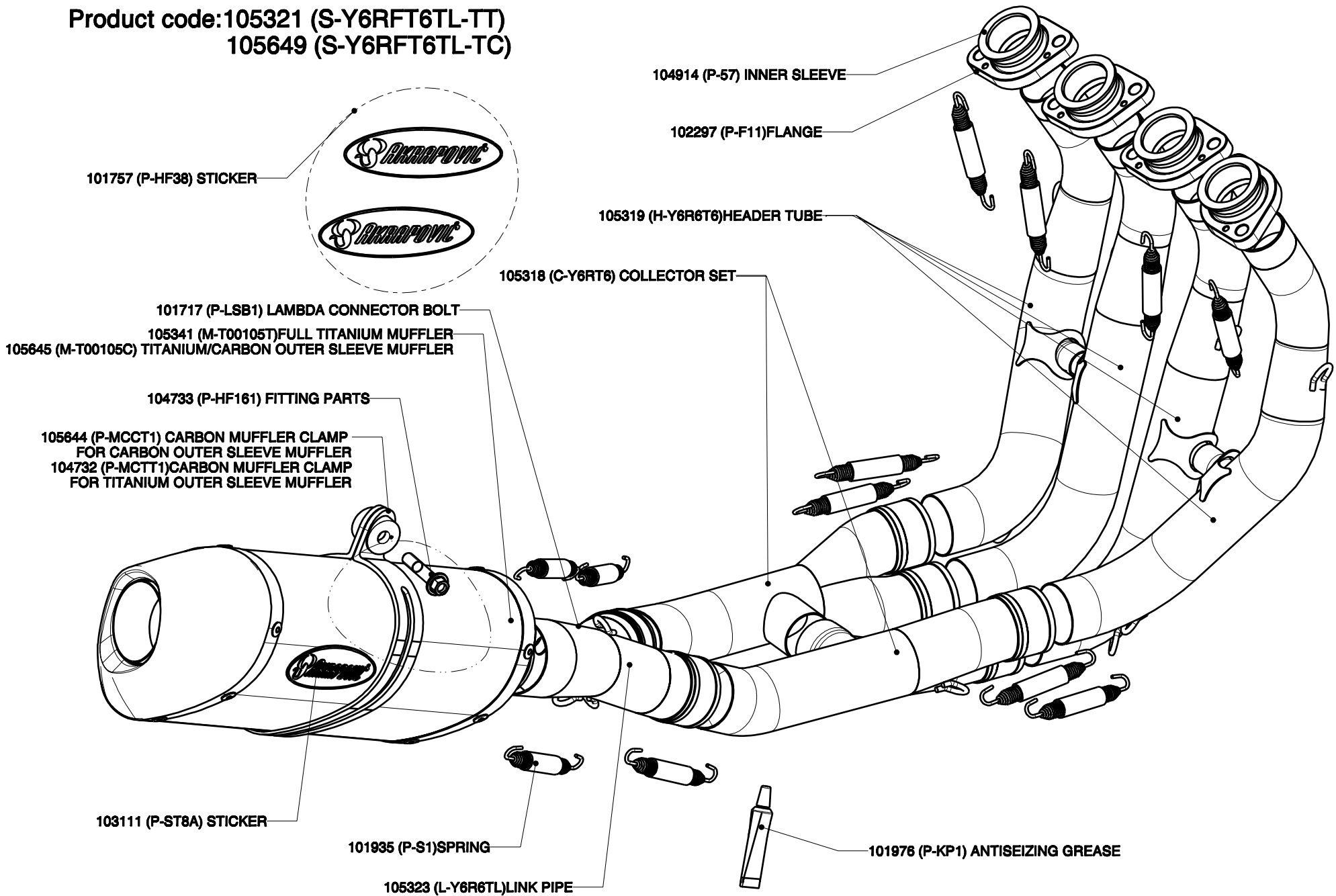

Yamaha YZF R6, Complete exhaust system/Racing line, model year:2006-2007 / HOMOLOGATED

Product code:105468 (S-Y6R6-HTT)
105648 (S-Y6R6-HTC)

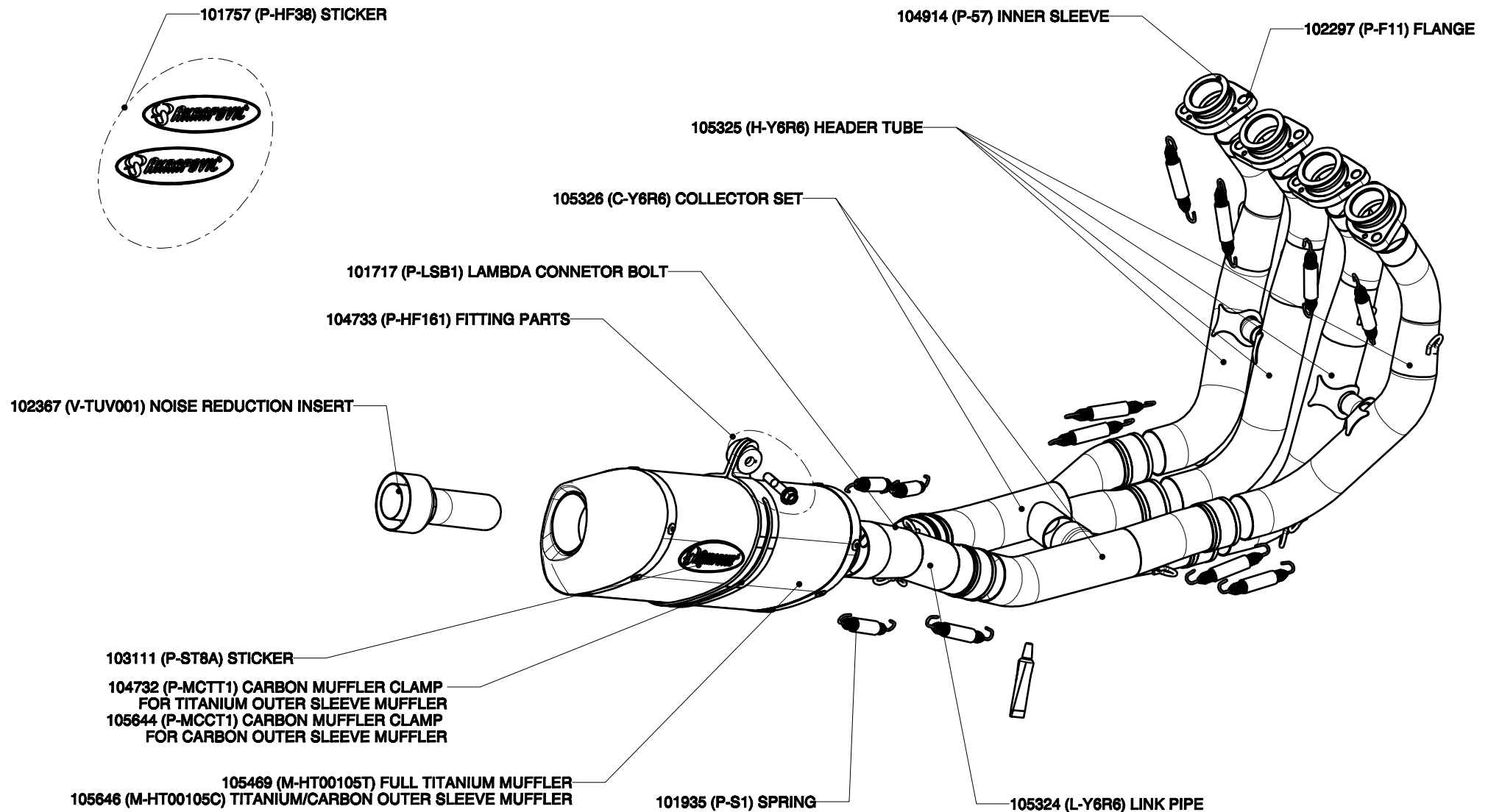

Yamaha YZF R6, Complete exhaust system/Evolution line, model year:2006-2007 / HOMOLOGATED

**Product code: 105467 (S-Y6RFT6TL-HTT)
105650 (S-Y6RFT6TL-HTC)**

