

## Installation instructions:

# AKRAPOVIC SLIP-ON EXHAUST SYSTEM for the KAWASAKI ZZR1400

Congratulations on purchasing an Akrapovic exhaust system. Please read these installation instructions carefully. If you have any trouble installing the system please contact your authorized dealer!

### IMPORTANT INFORMATION

#### Exclusion of Certain Liability

1. The manufacturer, importer or dealer shall not be liable for any incidental damage including personal injury or any other damages caused by improper installation or operation of the Akrapovic exhaust system. When installing the Akrapovic exhaust system be careful that the exhaust system does not touch other parts sensitive to high temperature.
2. Akrapovic makes no representation or warranties with regard to damage caused by the improper installation, use and maintenance of the Akrapovic exhaust system. The warranty is limited to defects recognized by our technical department and to normal use, and excludes items subject to normal wear (gaskets and damping wool). The guarantee is void in case of accident, modification, improper or competition use.
3. Do not attempt to install the Akrapovic exhaust system on a motorcycle for which it was not made or tested by Akrapovic.
4. When the exhaust system gets very hot during operation, be careful not to burn yourself on the exhaust system or parts which are in direct contact with it, even when the motor is not running. Also protect other people, especially children, from the injuries mentioned above.
5. In some cases Akrapovic exhaust system kits contain chemical products (ceramic anti-seizing grease; bolt sealant). Handle with care, do not inhale or swallow. Avoid excessive contact with skin, eyes or mucous membranes. Keep out of reach of children.
6. Technical specifications of Akrapovic exhaust systems and related products subject to change without notice.

#### Trademarks

The Akrapovic Exhaust System Technology logo is a registered trademark of Akrapovic d.d.

#### Symbols

The following symbols are used throughout these installation instructions:



**USE BOLT SEALANT;** Apply 3 to 4 small drops of bolt sealant onto the cleaned and degreased threads before tightening bolts. **WARNING! Avoid contact with skin, eyes and mucous membranes. Do not inhale fumes. Keep out of the reach of children.**



**USE ANTI-SEIZING GREASE (white tube);** Prevents seizing, corrosion and excessive wear between the titanium components of your exhaust system. **WARNING! Avoid eye contact. Avoid excessive skin contact. Keep out of the reach of children.**



**USE ANTI-SEIZE LEAD-FREE COPPER PASTE (black tube);** Provides trouble-free and long-lasting protection against seizing, corrosion and rusting of bolts, threaded ends, nuts, joints, etc. Also protects against vibration, wear and impact. **WARNING! Avoid eye contact. Avoid excessive skin contact. Keep out of the reach of children.**

## **INSTALLATION INSTRUCTIONS**

 **BEFORE INSTALLING CHECK SCHEMATIC OF THE EXHAUST SYSTEM!**

**!** IF ANY ITEMS IN THE AKRAPOVIC EXHAUST SYSTEM PACKAGE ARE MISSING PLEASE CONTACT YOUR AUTHORIZED DEALER. KEEP THE SCHEMATIC FOR FUTURE REFERENCE.

**!** THESE INSTALLATION INSTRUCTIONS MUST BE READ CAREFULLY IN ORDER TO ENSURE PROPER INSTALLATION AND OPERATION OF THE AKRAPOVIC EXHAUST SYSTEM.

**!** THE EXHAUST SYSTEM CAN BE EXTREMELY HOT. ALLOW THE MOTORCYCLE TO COOL DOWN BEFORE BEGINNING INSTALLATION.

 **WE ADVISE YOU TO LEAVE INSTALLATION TO A QUALIFIED SERVICEMAN. IMPROPER INSTALLATION MAY RESULT IN A SHORTER LIFETIME OF THE EXHAUST SYSTEM AND/OR DAMAGE TO THE MOTORCYCLE.**



T-handle 14mm wrench  
T-handle 12mm swiveling wrench  
T-handle 5mm three hexagon key wrench  
T-handle 6mm three hexagon key wrench  
Combination 14mm wrench  
Spring puller

### **REMOVAL OF STOCK EXHAUST SYSTEM:**

1. Put the motorcycle on a side stand, we recommend a racing stand. Make sure, that surface is solid and flat.
2. Unscrew the bolts from the metal clamp at the muffler - collector joint, link-pipe bracket and muffler sub-frame bracket. Remove the muffler. Perform the process on both sides of the motorcycle (**Figure 1, 2, 3, 4**).



Figure 1



Figure 2



Figure 3



Figure 4

**INSTALLATION OF THE AKRAPOVIC SLIP-ON EXHAUST SYSTEM:**

1. Insert the catalyst into the link pipe (**Figure 5, 6**). Coat the bolts and interior of the metal clamps with Akrapovic anti-seize lead-free copper paste (black tube) and correctly install them onto both link pipes (**Figure 7, 8**).



**Figure 5**



**Figure 6**

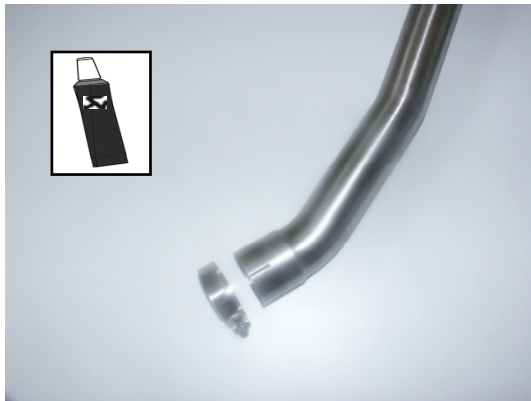

**Figure 7**



**Figure 8**

2. Slide both link pipes onto the stock collector and attach the link pipes brackets to the frame using stock bolts, washers and nuts. Hand tighten the bolts of both link pipe clamps (**Figure 9, 10, 11**).



**Figure 9**



**Figure 10**





Figure 11

3. Correctly position the carbon-fiber clamps and slide them onto the mufflers - bear in mind **the left offset** of the carbon-fiber clamp viewed from the rear for right side and **the right offset** for the left side. **WARNING! open the clamps slightly wider than the diameter of the outer sleeve of the mufflers – do not scrape them along the mufflers outer sleeve!** (Figure 12, 13).



Figure 12



Figure 13

4. Position the mufflers correctly, slide them onto the outlet sides of the link pipes and attach the springs (**Figure 14, 15**). Align the mufflers in respect to the motorcycle. Tighten the bolts on the carbon-fiber clamps/stock muffler brackets joints using stock bolts, washers, Akrapovic aluminium spacers and nuts as shown in figures (**Figure 16, 17, 18, 19**). Make sure, that the link pipe or muffler are not touching the frame or any other part of the motorcycle. **WARNING! make sure, that springs pull the muffler all the way onto the link pipe – use rubber mallet if necessary to tap the connections into place!**



Figure 14



Figure 15



Figure 16



Figure 17



Figure 18

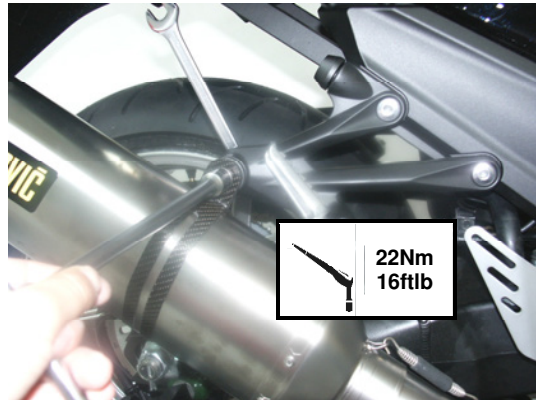

Figure 19

5. Tighten the link pipes brackets and the metal clamps (Figure 20, 21).

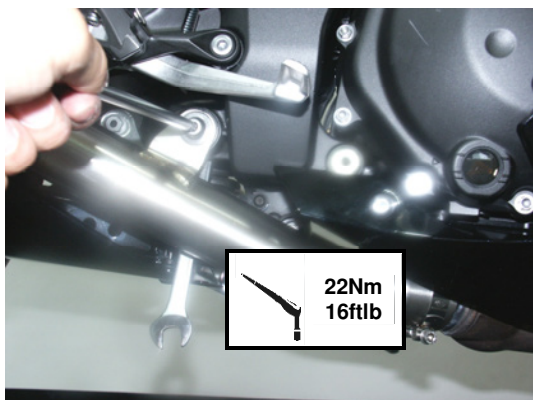

Figure 20

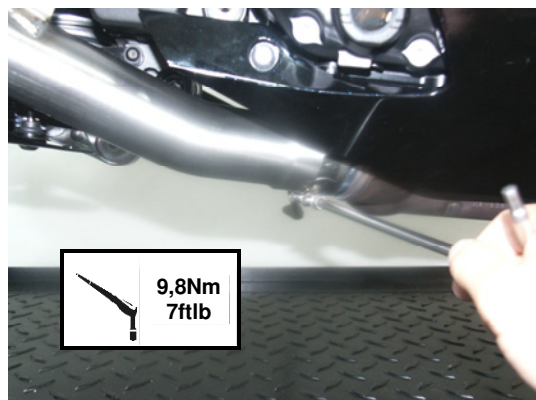

Figure 21

#### Final installation:

1. Clean grease spots:
  - a. Muffler – carbon-fiber outer sleeve: use a soft dry cloth.
  - b. Muffler – titanium outer sleeve: use a soft cloth sprayed with a multi-purpose spray lubricant (WD-40 or equivalent).
  - c. Muffler – carbon-fiber outlet cap: use a soft dry cloth.
  - d. Stainless steel link pipe: use a soft cloth sprayed with a contact cleaner, then wipe with a soft dry cloth.
  - e. Titanium inlet cap and welded link pipe: use a soft cloth sprayed with a multi-purpose spray lubricant (WD-40 or equivalent).

Cleaning will prevent spots from burning onto the surface. Do not use aggressive chemical cleaners, because they can damage the sticker.

Position of the correctly installed Akrapovic **SLIP-ON** system (Figure 22).



Figure 22

2. Check the operation of the brakes and suspension. Make sure all the bolts are sufficiently tightened. In case the exhaust system touches the cowling or other parts repeat the adjustment of the exhaust system or contact your authorized dealer.

**! IT IS NORMAL IF WHITE SMOKE COMES OUT OF THE MUFFLER ON FIRST OPERATION.**

**! DO NOT STAND BEHIND THE MUFFLER ON FIRST OPERATION.**

**! DO NOT USE AUTOMOTIVE WHEEL CLEANERS OR ANY CLEANING PRODUCTS WHICH CONTAIN ACIDIC ADDITIVES TO CLEAN AKRAPOVIC EXHAUST SYSTEMS.**

#### **MAINTENANCE OF THE AKRAPOVIC EXHAUST SYSTEM**

1. Clean the titanium exhaust components with a multi-purpose spray lubricant (WD-40 or equivalent), carbon fiber exhaust components with soft and dry cloth and stainless steel components with soft cloth sprayed with contact cleaner, then wipe with soft and dry cloth. Do not use aggressive chemical cleaners, because they can damage the sticker. A change in the color of the exhaust system is normal due to the high temperatures.
2. The wearing out of the muffler silencing material depends on the type of the engine and riding style. Contact your dealer/serviceman if visible changes appear on muffler's outer sleeve or the noise level is increased.
3. Periodically make sure all the bolts and springs are sufficiently tight.



## Installation instructions:

# AKRAPOVIC SLIP-ON EXHAUST SYSTEM for the KAWASAKI ZZR1400

Congratulations on purchasing an Akrapovic exhaust system. Please read these installation instructions carefully. If you have any trouble installing the system please contact your authorized dealer!

### IMPORTANT INFORMATION

#### Exclusion of Certain Liability

1. The manufacturer, importer or dealer shall not be liable for any incidental damage including personal injury or any other damages caused by improper installation or operation of the Akrapovic exhaust system. When installing the Akrapovic exhaust system be careful that the exhaust system does not touch other parts sensitive to high temperature.
2. Akrapovic makes no representation or warranties with regard to damage caused by the improper installation, use and maintenance of the Akrapovic exhaust system. The warranty is limited to defects recognized by our technical department and to normal use, and excludes items subject to normal wear (gaskets and damping wool). The guarantee is void in case of accident, modification, improper or competition use.
3. Do not attempt to install the Akrapovic exhaust system on a motorcycle for which it was not made or tested by Akrapovic.
4. When the exhaust system gets very hot during operation, be careful not to burn yourself on the exhaust system or parts which are in direct contact with it, even when the motor is not running. Also protect other people, especially children, from the injuries mentioned above.
5. In some cases Akrapovic exhaust system kits contain chemical products (ceramic anti-seizing grease; bolt sealant). Handle with care, do not inhale or swallow. Avoid excessive contact with skin, eyes or mucous membranes. Keep out of reach of children.
6. Technical specifications of Akrapovic exhaust systems and related products subject to change without notice.

#### Trademarks

The Akrapovic Exhaust System Technology logo is a registered trademark of Akrapovic d.d.

#### Symbols

The following symbols are used throughout these installation instructions:



**USE BOLT SEALANT;** Apply 3 to 4 small drops of bolt sealant onto the cleaned and degreased threads before tightening bolts. **WARNING! Avoid contact with skin, eyes and mucous membranes. Do not inhale fumes. Keep out of the reach of children.**



**USE ANTI-SEIZING GREASE (white tube);** Prevents seizing, corrosion and excessive wear between the titanium components of your exhaust system. **WARNING! Avoid eye contact. Avoid excessive skin contact. Keep out of the reach of children.**



**USE ANTI-SEIZE LEAD-FREE COPPER PASTE (black tube);** Provides trouble-free and long-lasting protection against seizing, corrosion and rusting of bolts, threaded ends, nuts, joints, etc. Also protects against vibration, wear and impact. **WARNING! Avoid eye contact. Avoid excessive skin contact. Keep out of the reach of children.**

## **INSTALLATION INSTRUCTIONS**

 **BEFORE INSTALLING CHECK SCHEMATIC OF THE EXHAUST SYSTEM!**

**! IF ANY ITEMS IN THE AKRAPOVIC EXHAUST SYSTEM PACKAGE ARE MISSING PLEASE CONTACT YOUR AUTHORIZED DEALER. KEEP THE SCHEMATIC FOR FUTURE REFERENCE.**

**! THESE INSTALLATION INSTRUCTIONS MUST BE READ CAREFULLY IN ORDER TO ENSURE PROPER INSTALLATION AND OPERATION OF THE AKRAPOVIC EXHAUST SYSTEM.**

**! THE EXHAUST SYSTEM CAN BE EXTREMELY HOT. ALLOW THE MOTORCYCLE TO COOL DOWN BEFORE BEGINNING INSTALLATION.**

 **WE ADVISE YOU TO LEAVE INSTALLATION TO A QUALIFIED SERVICEMAN. IMPROPER INSTALLATION MAY RESULT IN A SHORTER LIFETIME OF THE EXHAUST SYSTEM AND/OR DAMAGE TO THE MOTORCYCLE.**



T-handle 14mm wrench  
T-handle 12mm swiveling wrench  
TCRX 45 wrench  
T-handle 6mm three hexagon key wrench  
Combination 14mm wrench  
Spring puller

### **REMOVAL OF STOCK EXHAUST SYSTEM:**

1. Put the motorcycle on a side stand, we recommend a racing stand. Make sure, that surface is solid and flat.
2. Unscrew the bolts from the metal clamp at the muffler - collector joint, link-pipe bracket and muffler sub-frame bracket. Remove the muffler. Perform the process on both sides of the motorcycle (**Figure 1, 2, 3, 4**).



Figure 1



Figure 2



Figure 3



Figure 4



**INSTALLATION OF THE AKRAPOVIC SLIP-ON EXHAUST SYSTEM:**

1. Insert the catalyst into the link pipe (**Figure 5, 6**). Coat the bolts and interior of the metal clamps with Akrapovic anti-seize lead-free copper paste (black tube) and correctly install them onto both link pipes (**Figure 7, 8**).



**Figure 5**



**Figure 6**

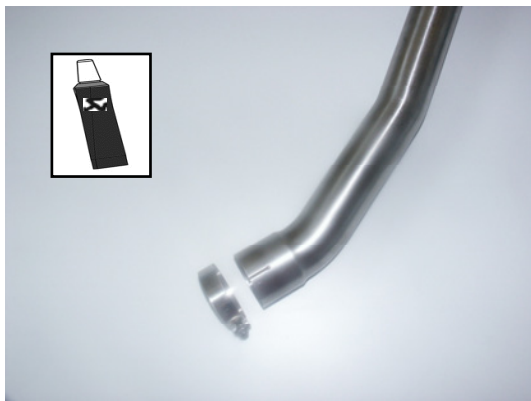

**Figure 7**



**Figure 8**

2. Slide both link pipes onto the stock collector and attach the link pipes brackets to the frame using stock bolts, washers and nuts. Hand tighten the bolts of both link pipe clamps (**Figure 9, 10, 11**).



**Figure 9**



**Figure 10**



Figure 11

3. Correctly position the carbon-fiber clamps and slide them onto the mufflers - bear in mind **the left offset** of the carbon-fiber clamp viewed from the rear for right side and **the right offset** for the left side. **WARNING! open the clamps slightly wider than the diameter of the outer sleeve of the mufflers – do not scrape them along the mufflers outer sleeve!** (Figure 12, 13).



Figure 12



Figure 13

4. Position the mufflers correctly, slide them onto the outlet sides of the link pipes and attach the springs (Figure 14, 15). Align the mufflers in respect to the motorcycle. Tighten the bolts on the carbon-fiber clamps/stock muffler brackets joints using stock bolts, washers, Akrapovic aluminium spacers and nuts as shown in figures (Figure 16, 17, 18, 19). Make sure, that the link pipe or muffler are not touching the frame or any other part of the motorcycle. **WARNING! make sure, that springs pull the muffler all the way onto the link pipe – use rubber mallet if necessary to tap the connections into place!**



Figure 14



Figure 15



Figure 16



Figure 17



Figure 18

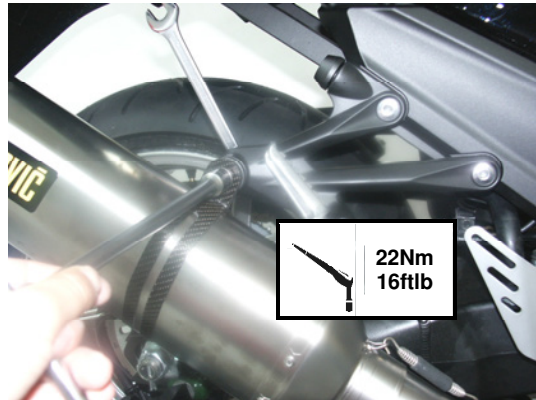

Figure 19

5. Tighten the link pipes brackets and the metal clamps (Figure 20, 21).

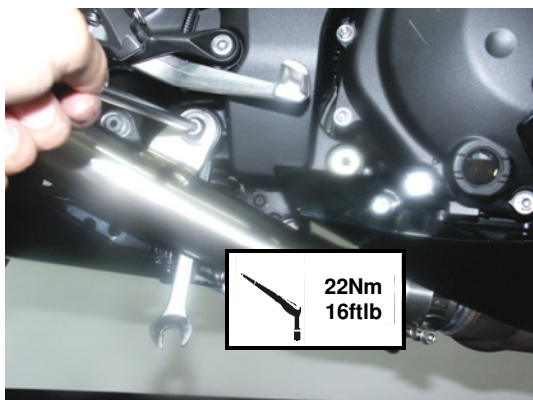

Figure 20

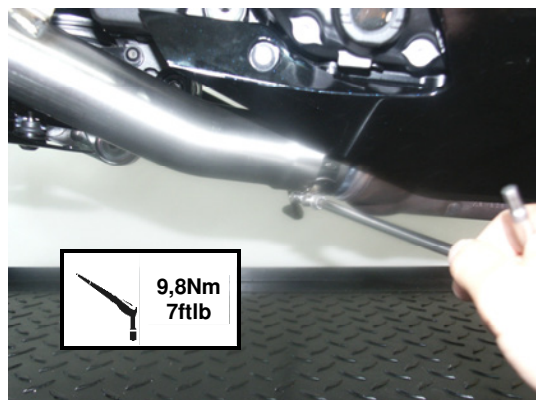

Figure 21



**Final installation:**

1. Clean grease spots:
  - a. Muffler – carbon-fiber outer sleeve: use a soft dry cloth.
  - b. Muffler – titanium outer sleeve: use a soft cloth sprayed with a multi-purpose spray lubricant (WD-40 or equivalent).
  - c. Muffler – carbon-fiber outlet cap: use a soft dry cloth.
  - d. Stainless steel link pipe: use a soft cloth sprayed with a contact cleaner, then wipe with a soft dry cloth.
  - e. Titanium inlet cap and welded link pipe: use a soft cloth sprayed with a multi-purpose spray lubricant (WD-40 or equivalent).

Cleaning will prevent spots from burning onto the surface. Do not use aggressive chemical cleaners, because they can damage the sticker.

Position of the correctly installed Akrapovic **SLIP-ON** system (**Figure 22**).



*Figure 22*

2. Check the operation of the brakes and suspension. Make sure all the bolts are sufficiently tightened. In case the exhaust system touches the cowling or other parts repeat the adjustment of the exhaust system or contact your authorized dealer.

**! IT IS NORMAL IF WHITE SMOKE COMES OUT OF THE MUFFLER ON FIRST OPERATION.**

**! DO NOT STAND BEHIND THE MUFFLER ON FIRST OPERATION.**

**! DO NOT USE AUTOMOTIVE WHEEL CLEANERS OR ANY CLEANING PRODUCTS WHICH CONTAIN ACIDIC ADDITIVES TO CLEAN AKRAPOVIC EXHAUST SYSTEMS.**

**MAINTENANCE OF THE AKRAPOVIC EXHAUST SYSTEM**

1. Clean the titanium exhaust components with a multi-purpose spray lubricant (WD-40 or equivalent), carbon fiber exhaust components with soft and dry cloth and stainless steel components with soft cloth sprayed with contact cleaner, then wipe with soft and dry cloth. Do not use aggressive chemical cleaners, because they can damage the sticker. A change in the color of the exhaust system is normal due to the high temperatures.
2. The wearing out of the muffler silencing material depends on the type of the engine and riding style. Contact your dealer/serviceman if visible changes appear on muffler's outer sleeve or the noise level is increased.
3. Periodically make sure all the bolts and springs are sufficiently tight.

**WARNING:**

Please note that certain aftermarket exhaust systems may not comply with applicable California laws and regulations, and may therefore be prohibited for use on California highways or roads, or on roads or vehicles otherwise subject to emissions control requirements.

Akrapovič exhaust systems for automobiles and motorcycles mounted downstream of the catalytic converter (also known as “cat-back systems”) are considered “replacement parts” in California by the California Air Resources Board (CARB), and do not require an exemption or executive order from CARB to be sold in California. However, California prohibits the use of any aftermarket exhaust system that modifies, removes or replaces original equipment catalysts, unless CARB has issued an Executive Order as to such part or system.

Further, Akrapovič parts or exhaust systems used or intended for use on “racing vehicles” (i.e. a competition vehicle used exclusively for competition on closed-course circuits) do not require an exemption or Executive Order from CARB to be sold in California. However, such parts are prohibited from use on California public highways or roads, even if occasionally used “off-road.”