

## Installation instructions:

# AKRAPOVIČ EVOLUTION OPEN EXHAUST SYSTEM for the DUCATI 1098, 1098S, 1098R, 848, 1198, 1198S, 1198R, 848EVO

Congratulations on purchasing an Akrapovič exhaust system. Please read these installation instructions carefully. If you have any trouble installing the system please contact your authorized dealer!

### IMPORTANT INFORMATION

#### Exclusion of Certain Liability

1. The manufacturer, importer or dealer shall not be liable for any incidental damage including personal injury or any other damages caused by improper installation or operation of the Akrapovič exhaust system. When installing the Akrapovič exhaust system be careful that the exhaust system does not touch other parts sensitive to high temperature.
2. Akrapovič makes no representation or warranties with regard to damage caused by the improper installation, use and maintenance of the Akrapovič exhaust system. The warranty is limited to defects recognized by our technical department and to normal use, and excludes items subject to normal wear (gaskets and damping wool). The guarantee is void in case of accident, modification, improper or competition use.
3. Do not attempt to install the Akrapovič exhaust system on a motorcycle for which it was not made or tested by Akrapovič.
4. When the exhaust system gets very hot during operation, be careful not to burn yourself on the exhaust system or parts which are in direct contact with it, even when the motor is not running. Also protect other people, especially children, from the injuries mentioned above.
5. In some cases Akrapovič exhaust system kits contain chemical products (ceramic anti-seizing grease; bolt sealant). Handle with care, do not inhale or swallow. Avoid excessive contact with skin, eyes or mucous membranes. Keep out of reach of children.
6. Technical specifications of Akrapovič exhaust systems and related products subject to change without notice.

#### Symbols

The following symbols are used throughout these installation instructions:



**USE BOLT SEALANT;** Apply 3 to 4 small drops of bolt sealant onto the cleaned and degreased threads before tightening bolts. **WARNING! Avoid contact with skin, eyes and mucous membranes. Do not inhale fumes. Keep out of the reach of children.**



**USE ANTI-SEIZING GREASE (white tube);** Prevents seizing, corrosion and excessive wear between the titanium components of your exhaust system. **WARNING! Avoid eye contact. Avoid excessive skin contact. Keep out of the reach of children.**



**USE ANTI-SEIZE LEAD-FREE COPPER PASTE (black tube);** Provides trouble-free and long-lasting protection against seizing, corrosion and rusting of bolts, threaded ends, nuts, joints, etc. Also protects against vibration, wear and impact. **WARNING! Avoid eye contact. Avoid excessive skin contact. Keep out of the reach of children.**

## **INSTALLATION INSTRUCTIONS**

 **BEFORE INSTALLING CHECK SCHEMATIC OF THE EXHAUST SYSTEM!**

**!** IF ANY ITEMS IN THE AKRAPOVIC EXHAUST SYSTEM PACKAGE ARE MISSING PLEASE CONTACT YOUR AUTHORIZED DEALER. KEEP THE SCHEMATIC FOR FUTURE REFERENCE.

**!** THESE INSTALLATION INSTRUCTIONS MUST BE READ CAREFULLY IN ORDER TO ENSURE PROPER INSTALLATION AND OPERATION OF THE AKRAPOVIC EXHAUST SYSTEM.

**!** THE EXHAUST SYSTEM CAN BE EXTREMELY HOT. ALLOW THE MOTORCYCLE TO COOL DOWN BEFORE BEGINNING INSTALLATION.

 **WE ADVISE YOU TO LEAVE INSTALLATION TO A QUALIFIED SERVICEMAN. IMPROPER INSTALLATION MAY RESULT IN A SHORTER LIFETIME OF THE EXHAUST SYSTEM AND/OR DAMAGE TO THE MOTORCYCLE.**



T-handle 8 mm wrench  
T-handle swiveling 10 mm wrench  
T-handle 3 mm three hexagon key wrench  
T-handle 4 mm three hexagon key wrench  
T-handle 6 mm three hexagon key wrench  
Combination 10 mm wrench  
Combination 22 mm wrench  
Screwdriver for headless slotted screws  
Spring puller

### **REMOVAL OF STOCK EXHAUST SYSTEM:**

1. Put the motorcycle on a side stand, we recommend a racing stand. Make sure, that surface is solid and flat.
2. Unscrew the bolts from the muffler clamps and muffler bracket (**Figure 1, 2**). Unhook the stock springs and remove the mufflers with welded link-pipes (**Figure 3, 4**).



Figure 1



Figure 2



Figure 3



Figure 4

3. Unscrew and remove the right foot-shield and stock heat shield (Figure 5, 6).



Figure 5



Figure 6

4. Remove the lower and the middle parts of the cowling (Figure 7, 8, 9, 10).

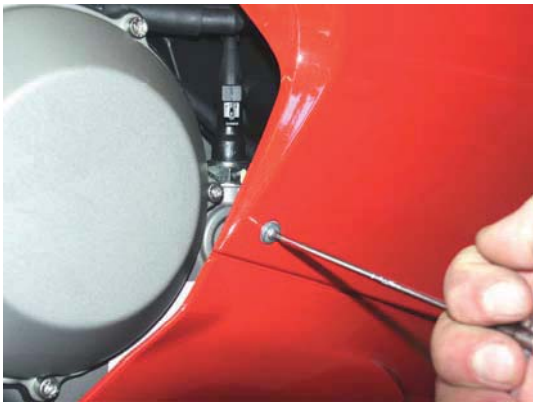

Figure 7



Figure 8



Figure 9



Figure 10

5. Cut the marked tie wrap and unscrew the rear cylinder's lambda sensor - **for the models with second lambda sensor only (Figure 11)**. Unscrew the collector bracket and rear header heat shield (Figure 12, 13). Unhook the springs from rear and front header-collector joints (Figure 14, 15). Temporarily unscrew the servo motor (Figure 16). **WARNING: do not disconnect the electrical installation of the servo motor!** Partially remove the collector – enough to unscrew the exhaust valve bracket (Figure 17, 18). Remove the cables from the valve (Figure 19). Remove the collector (Figure 20). Completely remove the exhaust valve cables from the motorcycle. Reattach the servo motor on the frame (without the cables!).

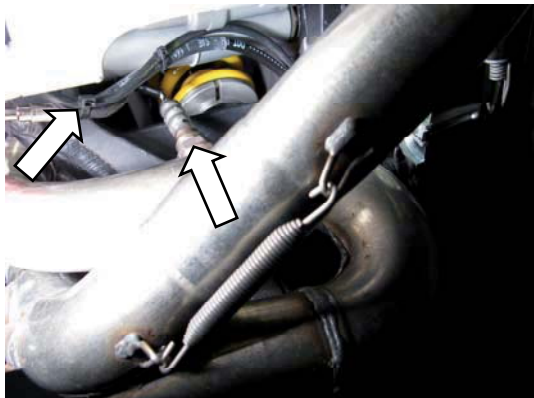

Figure 11

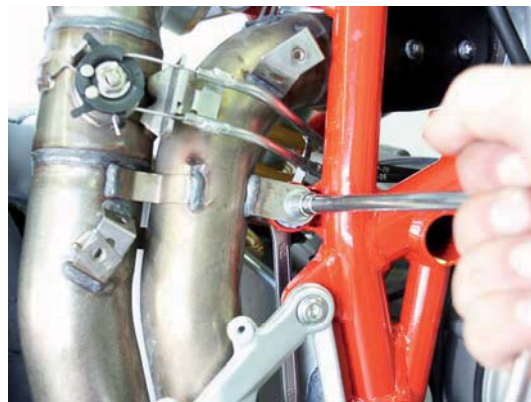

Figure 12



Figure 13

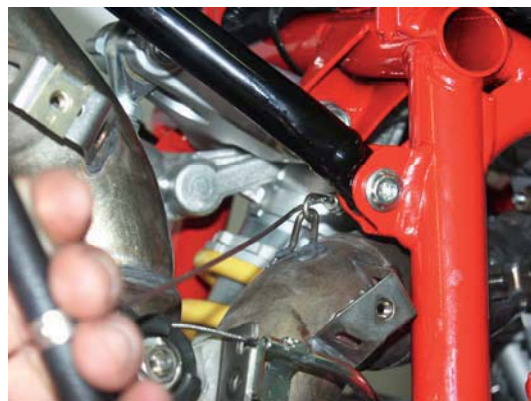

Figure 14



Figure 15



Figure 16

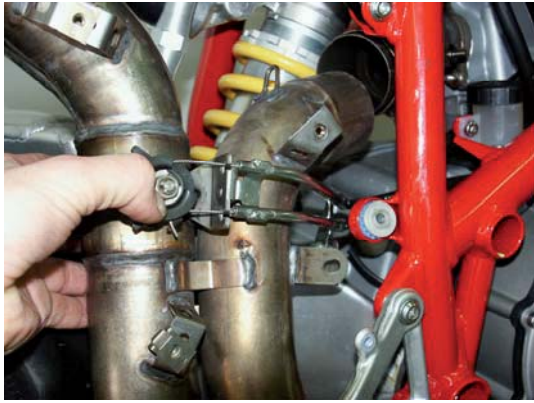

Figure 17

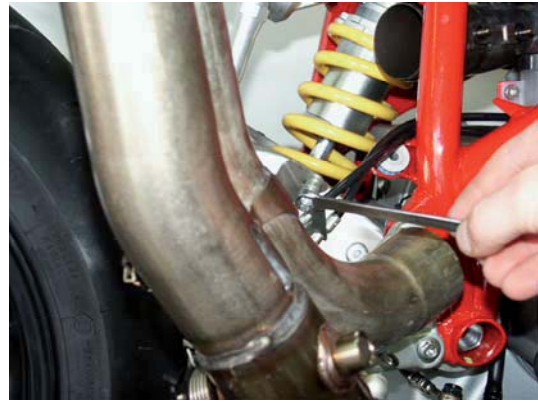

Figure 18



Figure 19



Figure 20

6. Unscrew the rear brake oil reservoir for easier access. **WARNING: do not disconnect the brake fluid tube!** Unscrew and remove the rear header tube – leave the stock gasket on the exhaust port (Figure 21, 22, 23). Unscrew and remove the front header's lambda sensor (Figure 24). Unscrew and remove the front header tube – leave the stock gasket on the exhaust port (Figure 25, 26).



Figure 21



Figure 22

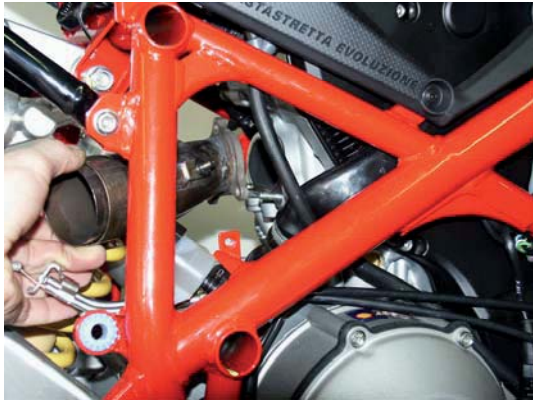

Figure 23



Figure 24



Figure 25



Figure 26

**INSTALLATION OF THE AKRAPOVIČ EVOLUZIONE EXHAUST SYSTEM:**

1. Remove the rubber spacer from stock collector and attach it to Akrapovič collector (Figure 27, 28).



Figure 27



Figure 28

2. Attach the front header tube (**Figure 29**). Tighten the lambda sensor (**Figure 30**). Attach the rear header tube and reinstall the rear brake oil reservoir (**Figure 31**). Slide the (front and rear headers to collector) link headers on headers and attach the springs (**Figure 32, 33, 34, 35**). Tighten the rear header bracket to the frame using stock bolt (**Figure 36**).

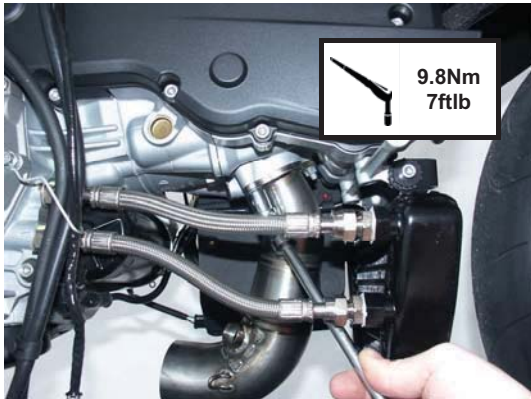

Figure 29

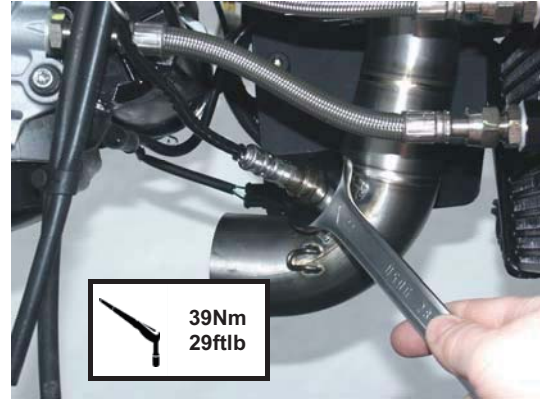

Figure 30

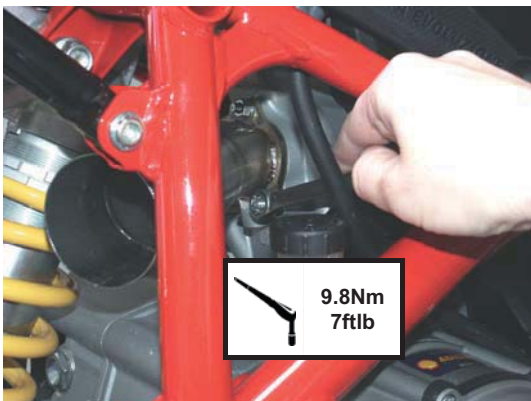

Figure 31



Figure 32



Figure 33



Figure 34

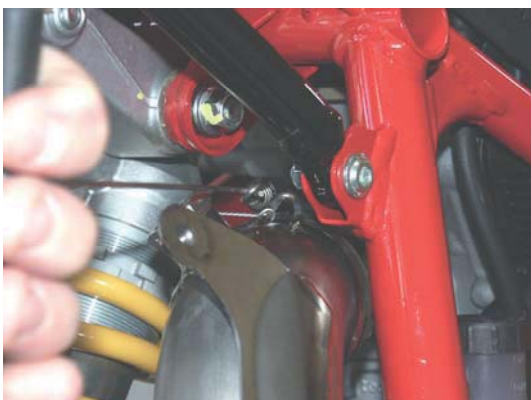

Figure 35

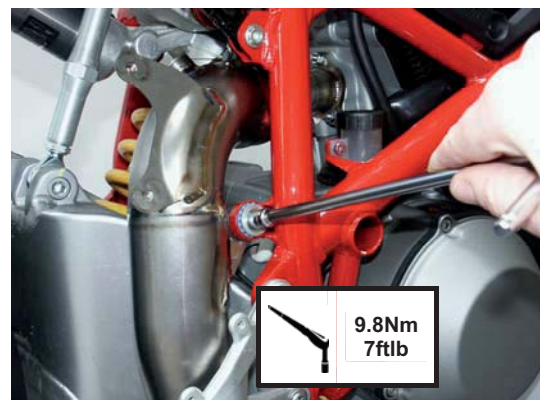

Figure 36

3. **For the models with second lambda sensor only:** redirect the lambda sensor's electrical lead to upper position, tighten the lambda sensor and secure the electrical lead, using tie wrap from installation kit (Figure 37, 38). **WARNING: secure the lambda sensor's electrical lead in such a way, that it doesn't touch any hot or moving parts!**



Figure 37

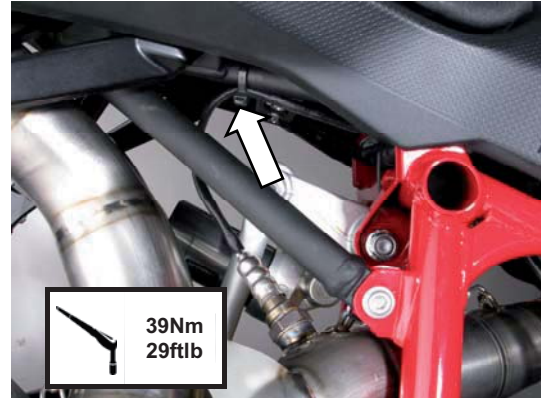

Figure 38

4. Slide the collector onto the link headers - coat the interior side of the input bushes of the collector with Akrapovič ceramic anti-seizing grease (white tube) and attach the springs (Figure 39, 40).

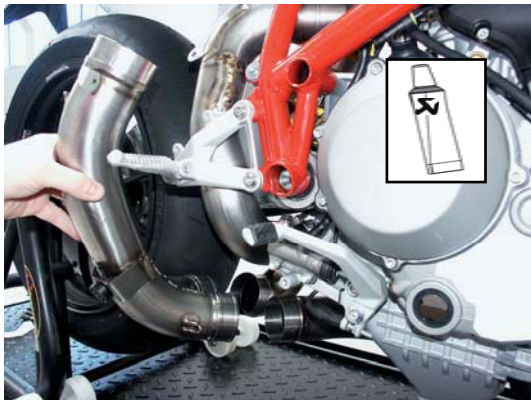

Figure 39



Figure 40

5. Slide the Y link pipe onto the collector - coat the interior side of the input bush of the Y link pipe with Akrapovič ceramic anti-seizing grease (white tube) and attach the spring (Figure 41, 42).



Figure 41



Figure 42



6. Correctly assemble the Akrapovič heat shield and tighten it onto the heat shield bracket (Figure 43, 44, 45). Reattach the stock foot shield (Figure 46).



Figure 43

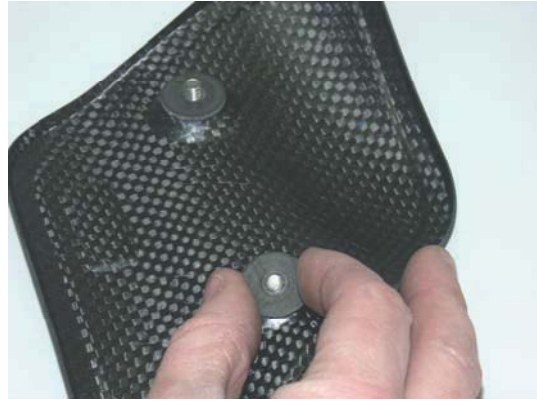

Figure 44

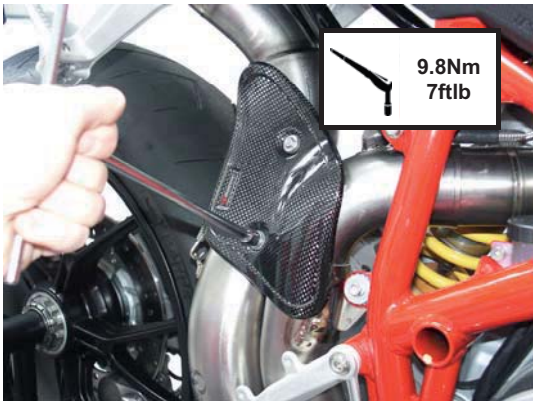

Figure 45



Figure 46

7. Correctly insert the “venturi” inserts into the inlets of both mufflers (Figure 47, 48). Slide the mufflers onto the Y link pipe (Figure 49). Attach the Akrapovič springs (Figure 50). Correctly position the carbon-fiber clamps and slide them onto the mufflers. **WARNING: open the clamps slightly wider than the diameter of the outer sleeve of the mufflers – do not scrape them along the mufflers outer sleeve!** Be careful not to damage paint or any other part of the motorcycle during this process! (Figure 51). Tighten the clamps using stock bolts and spacers (Figure 52). Make sure the mufflers or link pipes are not touching the frame or any other parts of the motorcycle.



Figure 47



Figure 48



Figure 49



Figure 50



Figure 51



Figure 52

**Final installation:**

1. Clean grease spots:
  - a. Muffler – titanium outer sleeve: use a soft cloth sprayed with a multi-purpose spray lubricant (WD-40 or equivalent).
  - b. Muffler – titanium outer sleeve: use a soft cloth sprayed with a multi-purpose spray lubricant (WD-40 or equivalent).
  - c. Muffler – carbon-fiber outlet cap: use a soft dry cloth.
  - d. EVOLUTION exhaust: stainless steel header tubes: use a soft cloth sprayed with a contact cleaner, then wipe with a soft dry cloth
  - e. EVOLUTION exhaust: titanium link headers, collector and Y link pipe: use a soft cloth sprayed with a multi-purpose spray lubricant (WD-40 or equivalent).

Cleaning will prevent spots from burning onto the surface. Do not use aggressive chemical cleaners, because they can damage the sticker.

2. **WARNING:** after running engine for 30 minutes, tighten the bolts on the Akrapovič carbon-fiber heat shields!

Position of the correctly installed Akrapovič **EVOLUTION** exhaust system (Figure 53).



Figure 53

3. Check the operation of the brakes and suspension. Make sure all the bolts are sufficiently tightened. In case the exhaust system touches the cowling or other parts repeat the adjustment of the exhaust system or contact your authorized dealer.

**! IT IS NORMAL IF WHITE SMOKE COMES OUT OF THE MUFFLER ON FIRST OPERATION.**

**! DO NOT STAND BEHIND THE MUFFLER ON FIRST OPERATION.**

**! DO NOT USE AUTOMOTIVE WHEEL CLEANERS OR ANY CLEANING PRODUCTS WHICH CONTAIN ACIDIC ADDITIVES TO CLEAN AKRAPOVIČ EXHAUST SYSTEMS.**

#### **MAINTENANCE OF THE AKRAPOVIČ EXHAUST SYSTEM**

1. Clean the titanium exhaust components with a multi-purpose spray lubricant (WD-40 or equivalent), carbon fiber exhaust components with soft and dry cloth and stainless steel components with soft cloth sprayed with contact cleaner, then wipe with soft and dry cloth. Do not use aggressive chemical cleaners, because they can damage the sticker. A change in the color of the exhaust system is normal due to the high temperatures.
2. The wearing out of the muffler silencing material depends on the type of the engine and riding style. Contact your dealer/serviceman if visible changes appear on muffler's outer sleeve or the noise level is increased.
3. Periodically make sure all the bolts and springs are sufficiently tight.

**DUCATI 1098, Complete exhaust system / EVOLUTION LINE**  
**DUCATI 1098 S,**  
**DUCATI 848,**  
**DUCATI 848 EVO,**

**Product code: S-D10EFT2T-ZC**  
**S-D10EFT2T-ZT**

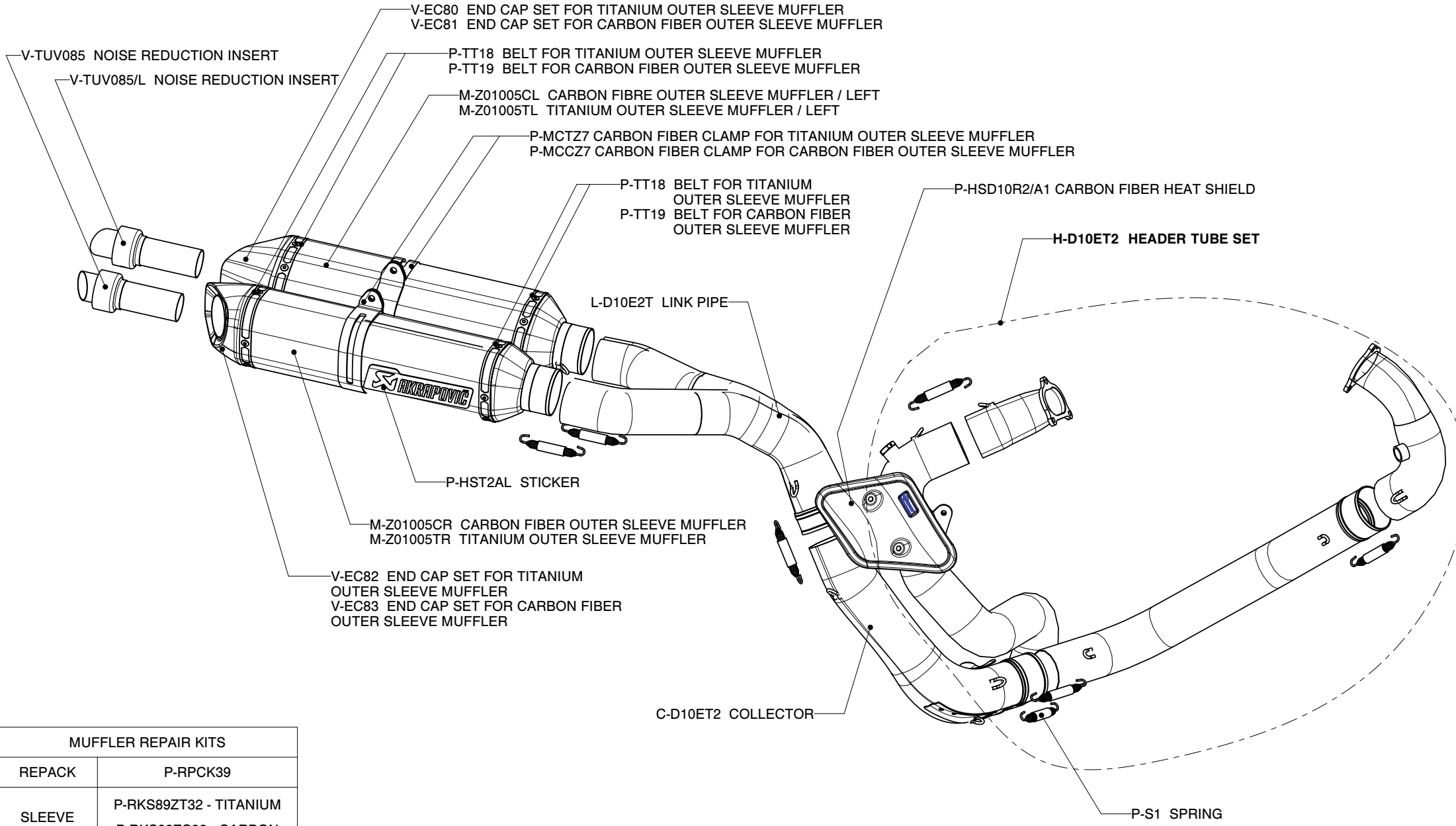

MUFFLER REPAIR KITS	
REPACK	P-RPCK39
SLEEVE	P-RKS89ZT32 - TITANIUM
	P-RKS88ZC32 - CARBON

DUCATI 1098,  
 DUCATI 1098 S,  
 DUCATI 848,  
 DUCATI 848 EVO,

**Complete exhaust system / EVOLUTION LINE /tube set with Street legal SLIP ON mufflers**

**Product code: S-D10EFT2T-ZT/1**

**WARNING! IN CASE OF COMBINATION WITH EVOLUTION TUBE SET, THE SLIP-ON HOMOLOGATION IS NOT VALID!**

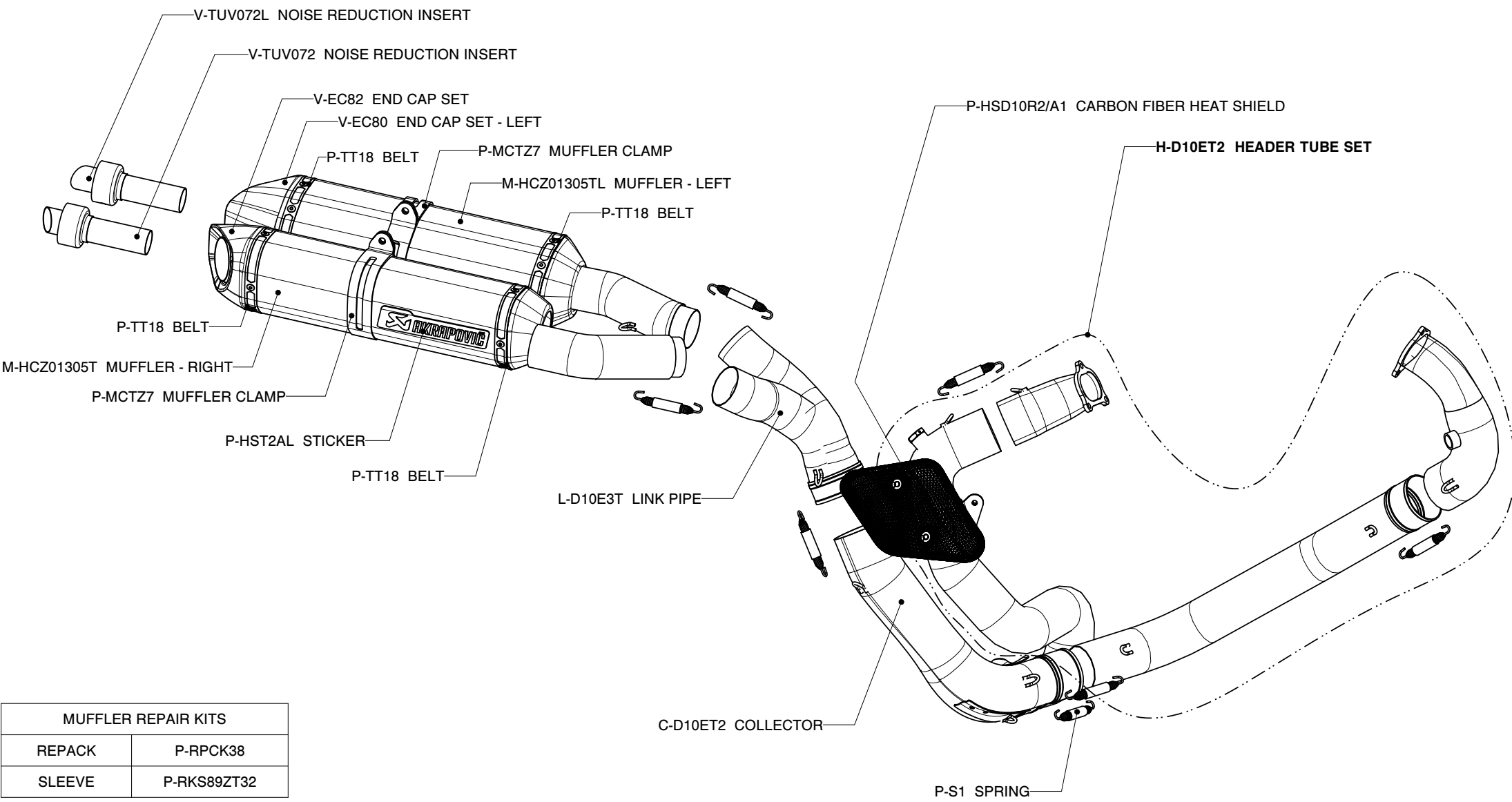

MUFFLER REPAIR KITS	
REPACK	P-RPCK38
SLEEVE	P-RKS89ZT32

DUCATI 1098R,  
 DUCATI 1198,  
 DUCATI 1198S,  
 DUCATI 1198R,

**Complete exhaust system / EVOLUTION LINE**

**Product code: S-D10EFT3T-ZC  
 S-D10EFT3T-ZT**

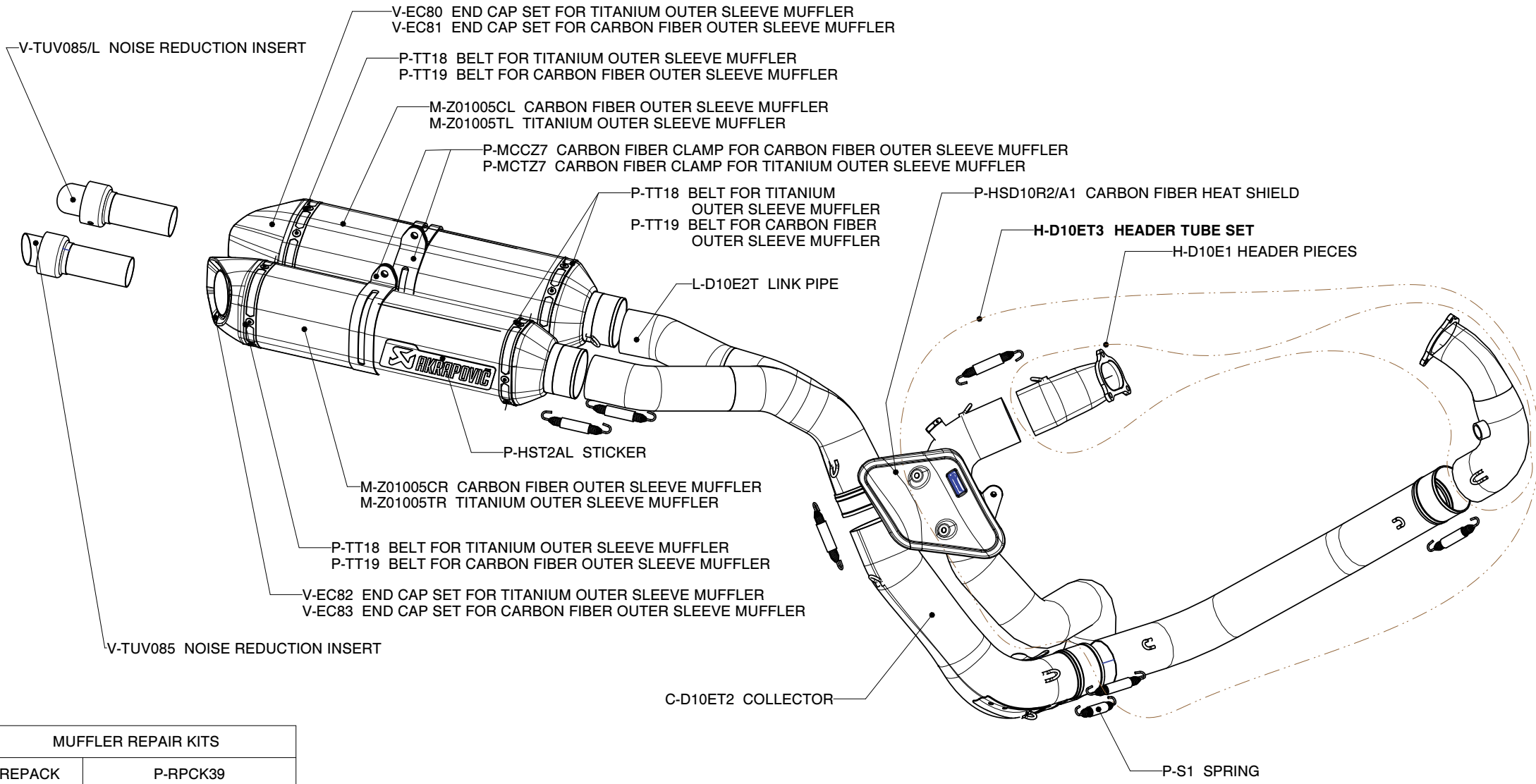

MUFFLER REPAIR KITS	
REPACK	P-RPCK39
SLEEVE	P-RKS89ZT32 - TITANIUM
	P-RKS88ZC32 - CARBON

DUCATI 1098R;  
 DUCATI 1198,  
 DUCATI 1198S,  
 DUCATI 1198R,

Complete exhaust system / EVOLUTION LINE/ tube set with Street legal SLIP ON mufflers

Product code: S-D10EFT3T-ZT/1

**WARNING! IN CASE OF COMBINATION WITH EVOLUTION TUBE SET, THE SLIP-ON HOMOLOGATION IS NOT VALID!**

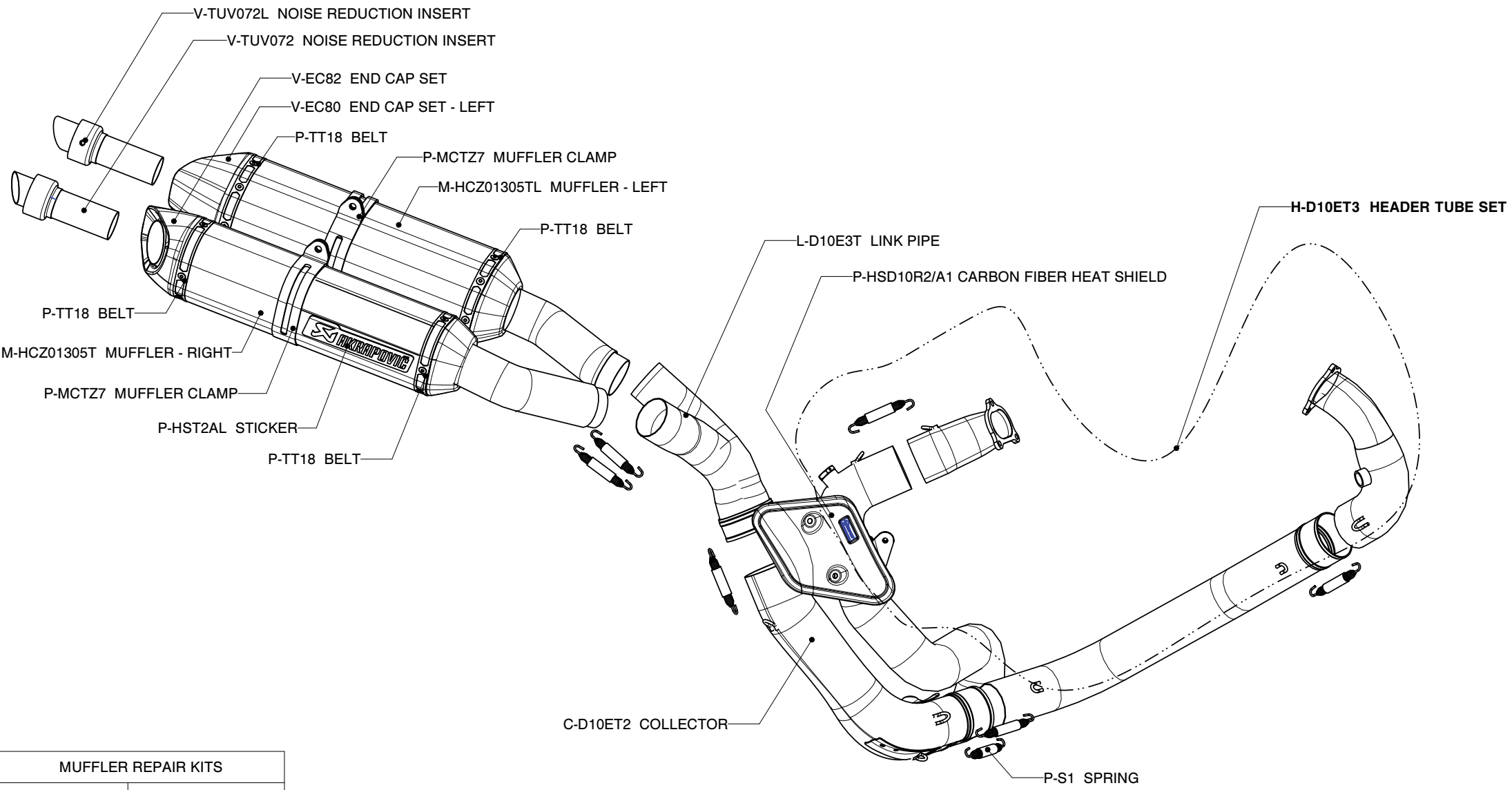

MUFFLER REPAIR KITS	
REPACK	P-RPCK38
SLEEVE	P-RKS89ZT32