



## Installation instructions

Akrapovič Exhaust System  
**Racing&Evolution**  
for the  
**BMW S1000RR**

Congratulations on purchasing the Akrapovič exhaust system.

**Please read this entire installation manual carefully prior to installing and using the Akrapovič exhaust system.**

Akrapovič exhaust system should only be installed by persons skilled in motorcycle exhaust system installation and performance. The instructions provided in this manual should be followed to ensure proper installation and safe use of the Akrapovič exhaust system. Akrapovič and/or its partners shall not be held liable for any damage or personal injury (including direct, indirect, or consequential damage) sustained as a result of improper installation of the Akrapovič exhaust system or its use and maintenance contrary to the instructions and warnings contained herein.

If you have any questions regarding the installation and/or proper use of the Akrapovič exhaust system or this manual, please contact your local Akrapovič partner.

## **GENERAL INFORMATION**

Your safety is our number one priority. Please ride your motorcycle responsibly, safely and always obey local traffic rules.

All statements made with regard to the exhaust system's compliance are made in respect of the exhaust system "as is". Any modifications of the Akrapovič exhaust system or its improper installation, use or maintenance that is not in accordance with this Installation manual, may result in severe damage to the exhaust system and/ or engine, as well as personal injury, and may affect the exhaust system's compliance with the legal requirements, such as exhaust system's air and/ or noise emissions (as an example, the motorcycle may not be suitable for use on public roads any longer), as well as warranty coverage.

The exhaust system may only be used in accordance with relevant laws and regulations, including state and federal, where applicable.

Damage caused by improper installation, use and maintenance of the Akrapovič exhaust system is not covered by the Akrapovič warranty. Please refer to the enclosed warranty with regard to the terms of our warranty.

Technical specifications of Akrapovič exhaust systems and related products are subject to change without notice.

## **COPYRIGHT AND OTHER RIGHTS NOTICE**

The Akrapovič trademark, including corporate logos and emblems, are subject to copyright as well as trademark rights of Akrapovič, its licensors, or third persons authorizing Akrapovič to use them.

Any reproduction, technical or other manipulation, translation, or other use of the copyright and/or trademark rights contained herein is prohibited without the explicit prior written consent of Akrapovič. The same especially applies to the entire contents of this manual and/or any of its parts, including but not limited to technical specifications, instructions, graphs, photographs, and so on included in this manual.

The shape of the exhaust system is protected under a registered Community Design No. RCD 002747329-0001.

Akrapovič takes all copyright and other rights infringement cases under serious consideration. If you have any reason to believe that your exhaust system is not an original Akrapovič product, please contact our local partners or Akrapovič at [info@akrapovic.com](mailto:info@akrapovic.com).

## SAFETY AND COMPLIANCE WARNING, PLEASE READ CAREFULLY

**BEFORE REMOVING THE STOCK EXHAUST SYSTEM AND BEGINNING THE INSTALLATION OF YOUR NEW AKRAPOVIČ EXHAUST, PLEASE MAKE SURE THAT ALL ITEMS LISTED BELOW ARE VERIFIED:**

- THIS MANUAL IS SPECIFIC TO THE MOTORCYCLE INDICATED ON THE COVER PAGE, FOR WHICH IT IS DESIGNED. INSTALLATION PROCEDURES VARY DEPENDING ON THE TYPE OF MOTORCYCLE. PLEASE VERIFY THAT THE AKRAPOVIČ EXHAUST SYSTEM AND THIS INSTALLATION MANUAL CORRESPOND TO THE TYPE OF YOUR MOTORCYCLE.
- THE EXHAUST SYSTEM CAN GET EXTREMELY HOT DURING AND AFTER IT IS USED. MAKE SURE NOT TO TOUCH THE EXHAUST SYSTEM UNTIL IT IS COMPLETELY COOL. **ALLOW THE EXHAUST AND ENGINE TO COOL DOWN BEFORE BEGINNING INSTALLATION.**
- MAKE SURE THE MOTORCYCLE IS **SECURELY POSITIONED TO PREVENT TIPPING OVER** AND DAMAGE TO YOURSELF AND OTHERS, OR THE MOTORCYCLE.
- PLEASE CHECK THE PARTS YOU RECEIVED AGAINST THE PARTS LIST AVAILABLE ON OUR WEBSITE. MAKE SURE THAT YOU HAVE **ALL THE PARTS NECESSARY FOR THE INSTALLATION** OF YOUR NEW AKRAPOVIČ EXHAUST SYSTEM. IF ANY OF THE PARTS IS MISSING, PLEASE DO NOT PROCEED WITH UNINSTALLING YOUR STOCK EXHAUST SYSTEM/ INSTALLING THE AKRAPOVIČ EXHAUST SYSTEM AND CONTACT THE RETAILER WHERE YOU PURCHASED THE AKRAPOVIČ EXHAUST SYSTEM.
- ALWAYS **SECURE YOUR MOTORCYCLE'S GROUND CLEARANCE.** FOR ADVANCED USERS, WE RECOMMEND YOU CHECK THE MOTORCYCLE SPRING PRELOAD SETTINGS TO OPTIMIZE GROUND CLEARANCE WHERE POSSIBLE.
- EVERY EXHAUST SYSTEM MUFFLER HAS ITS UNIQUE SERIAL NUMBER, WHICH IDENTIFIES THE AUTHENTICITY OF THE PRODUCT. YOU CAN FIND THE SERIAL NUMBER ON THE MUFFLER'S INLET PIPE. PLEASE REFER TO THE PICTURE BELOW. PLEASE VERIFY THAT YOUR EXHAUST SYSTEM IS AN ORIGINAL AKRAPOVIČ PRODUCT. IF YOU HAVE ANY DOUBTS, PLEASE CONTACT THE RESELLER WHERE YOU PURCHASED THE EXHAUST SYSTEM OR AKRAPOVIČ PARTNERS. THIS MANUAL, ANY CERTIFICATES AND AKRAPOVIČ WARRANTY APPLY TO ORIGINAL PRODUCTS ONLY.

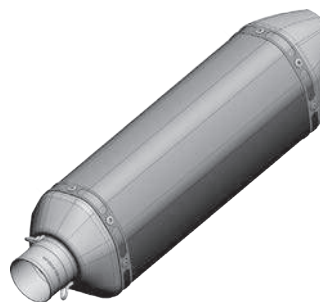
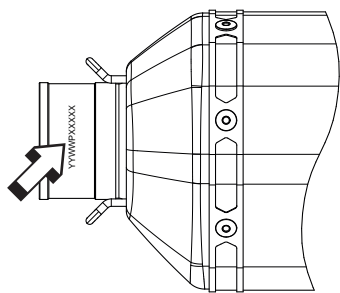

SERIAL NUMBER POSITION

## NOISE AND EMISSION WARNINGS

### General warning

Because of the world-wide distribution of Akrapovič d.d. products, neither Akrapovič d.d. nor any of its subsidiaries make any representation that the exhaust system complies with the air and/or noise emissions laws, or labeling laws, of any jurisdiction. The purchasers are entirely responsible for informing themselves of the applicable laws where the products are to be used and to comply with those law.

Although legal compliance of Akrapovič products in a specific country should be determined by the user, you can find some basic guidance on compliance of your Akrapovič exhaust system with various legal requirements on the product-related part of our website. For EC and ECE type approvals, please refer to the certificate enclosed to your product.

### USA WARNING

Various U.S. states and the U.S. federal government have individual laws regulating the use of aftermarket exhaust parts and systems, especially as those parts and systems modify, remove, or replace original equipment catalysts. Please consult the appropriate laws in your area before installing any aftermarket part or system on your vehicle to ensure compliance with all applicable laws. Neither Akrapovic d.d. nor any of their subsidiaries or the sellers of the parts or systems make any representation that any of their parts or systems comply with any such laws.

### CALIFORNIA WARNING

California laws prohibit the use of any aftermarket exhaust part or system that modifies, removes or replaces original equipment catalysts unless the California Air Resources Board has issued an Executive Order regarding such part or system or unless the part or system is exempted by being used only on racing vehicles on closed courses. Neither Akrapovic d.d. nor any of their subsidiaries make any representation that any of their parts or systems has received such an Executive Order or that any of their parts or systems conform with the racing vehicles exemption. The purchasers are entirely responsible for informing themselves of applicable California laws and to comply with those laws.

### GENERAL NOTE

Photographs and other illustrations in this manual are symbolic and are intended to help represent individual steps for proper installation and use, as well as for a general overview. The actual component parts of the Akrapovič exhaust system may not entirely correspond to the photographs and other illustrations.

### SYMBOLS

The following symbols are used throughout these installation instructions:



**TOOLS AND PROTECTIVE EQUIPMENT REQUIRED**



**TIGHTENING TORQUE**



**LUBRICATION**



**HAND TIGHTEN**



**INSTALLATION TIP**



**CAUTION OR IMPORTANT**

#### USE BOLT SEALANT



Apply 3 to 4 small drops of bolt sealant onto the cleaned and degreased threads before tightening the bolts.

**WARNING! Avoid contact with skin, eyes and mucous membranes. Do not inhale fumes. Keep out of reach of children.**

#### USE ANTI-SEIZE LEAD-FREE COPPER PASTE (black tube)



Provides trouble-free and long-lasting protection against seizing, corrosion and rusting of bolts, threaded ends, nuts, joints, etc. Also protects against vibration, wear and impact.

**WARNING! Avoid eye contact. Keep out of reach of children.**

#### USE ANTI-SEIZING GREASE (white tube)



Prevents seizing, corrosion and excessive wear between the titanium components of your exhaust system.

**WARNING! Avoid eye contact. Keep out of reach of children.**

## Tools & equipment

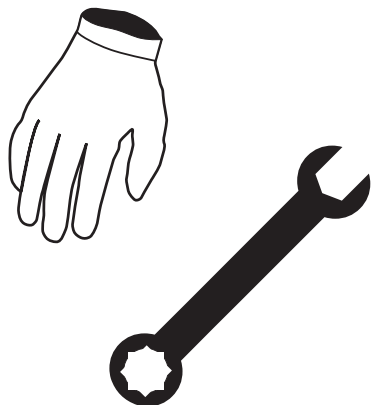

- Torx 25
- Torx 40
- Torx 45
- T-handle 12 mm wrench
- T-handle 13 mm wrench
- T-handle 3 mm three hexagon wrench
- T-handle 6 mm three hexagon wrench
- Combination 10 mm wrench
- Combination 13 mm wrench
- Combination 17 mm wrench
- Spring puller

## PARTS LIST

The following parts should be found in the box:

- Installation Manual
- Homologation certificate/ compliance documents if applicable
- Warranty
- Fitting material
- Muffler and pipes

## REMOVAL OF STOCK EXHAUST SYSTEM:

The process of uninstalling the original exhaust system may vary depending on the existing exhaust system. Please follow the original exhaust system manufacturer's instructions for uninstalling the original exhaust system.

If you for any reason decide otherwise, please note that any information provided in this respect herein should be considered as general information provided for your convenience only. Akrapovič shall not assume any liability or responsibility with regard to uninstalling your existing exhaust system, warranty coverage of such exhaust system or vehicle or their further fitness for use.

**In case your Akrapovič exhaust system may not be used on certain roads or under certain conditions, please keep the stock or other exhaust system that you can use in such circumstances legally.**

## REMOVAL OF STOCK EXHAUST SYSTEM:

1. Put the motorcycle on a side stand, we recommend a racing stand.
2. Unscrew the marked bolts from the muffler hanging bracket and the metal clamp at the muffler-collector connection (**Figure 1**). Remove the muffler together with heatshield.



Figure 1

3. Remove the metal collar and rubber damper from the stock muffler hanging bracket (**Figure 2**).

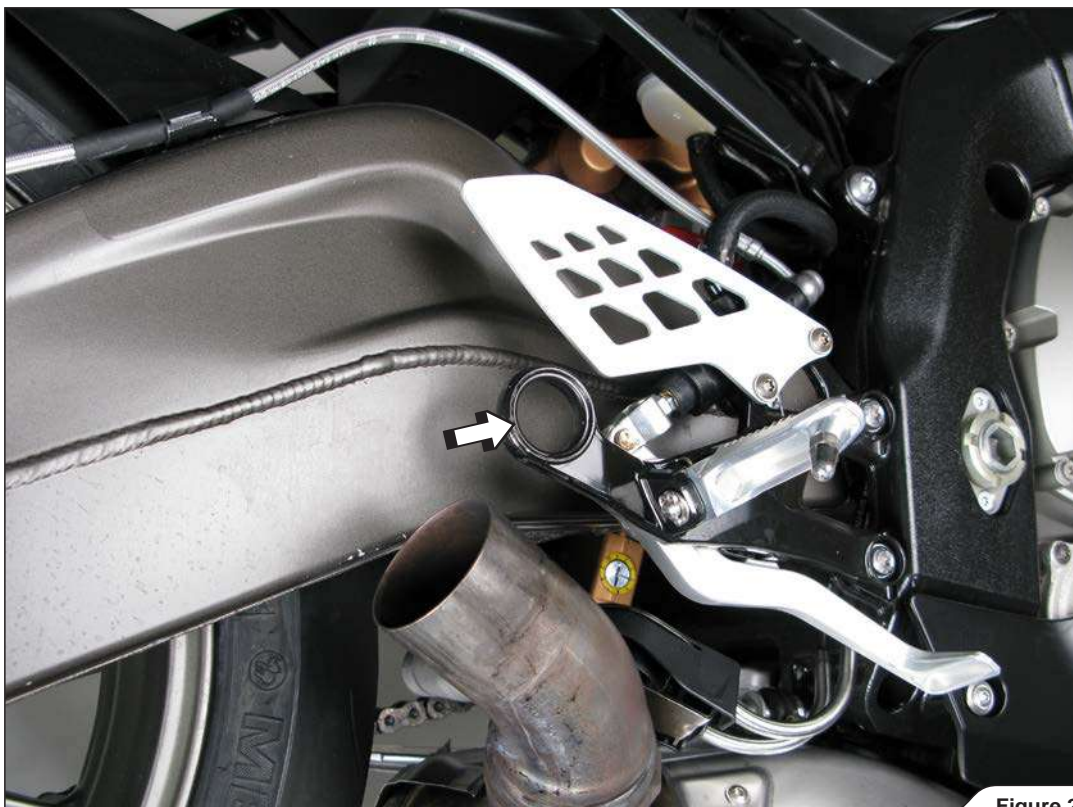

Figure 2



4. Unscrew both rider's seat screws and remove the seat (**Figure 3**).



Figure 3

5. Unscrew marked bolts and remove the fuel tank side covers on both sides of the motorcycle (**Figure 4**).



Figure 4

6. Remove the stock exhaust valve cables from servo motor (Figure 5).

! **IMPORTANT:** do not turn the the servo motor wheel with force or the servo motor could be damaged!

! **IMPORTANT:** do not disconnect the servo's electrical connector or remove the servo motor off the vehicle!



Figure 5

7. Free the cables from the motorcycle (Figure 6).

! **IMPORTANT:** make sure not to scratch or damage any part of the motorcycle during removal of the cables!



Figure 6



8. Unscrew the marked bolts on both sides of the motorcycle and remove the lower and middle parts of the cowling (Figure 7, 8, 9).



Figure 7



Figure 8



**!** IMPORTANT: disconnect the turn signal electrical connectors during removal of the middle cowling (Figure 9)!



Figure 9

9. Pull the radiator's bracket off the radiators (Figure 10).

**!** IMPORTANT: make sure not to damage the radiator's cooling fins!

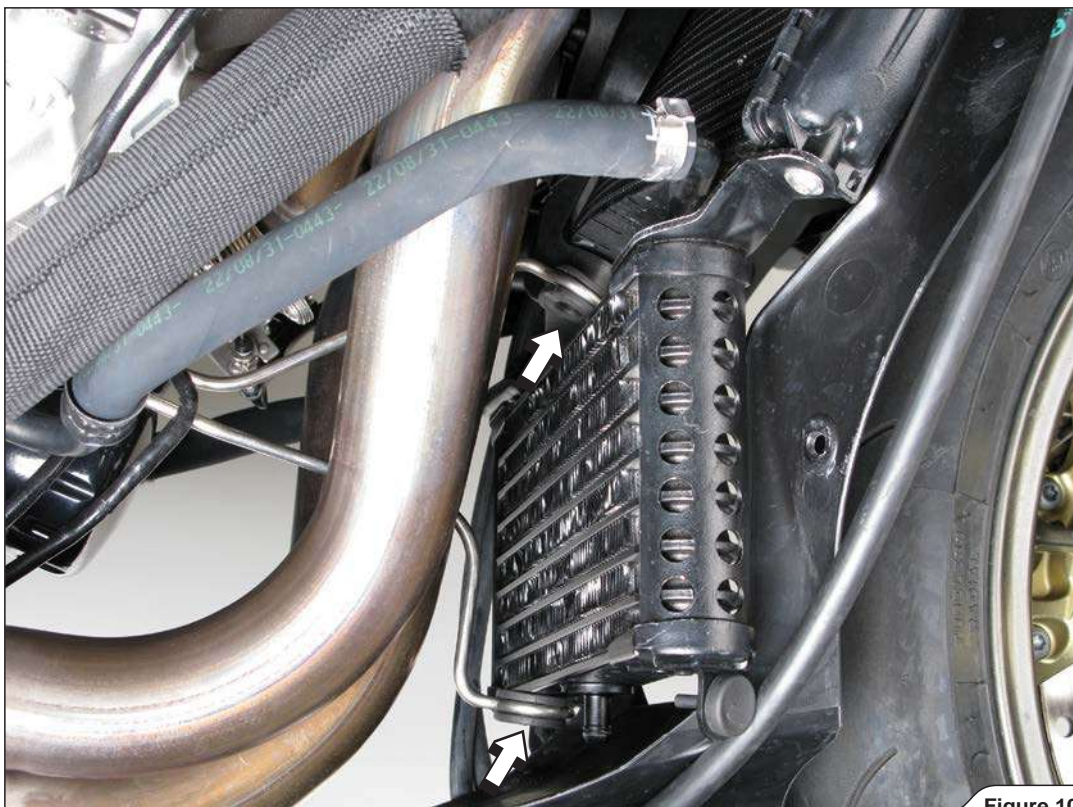

Figure 10



10. Unscrew the radiator's bracket off the engine block and both lambda sensors (Figure 11).

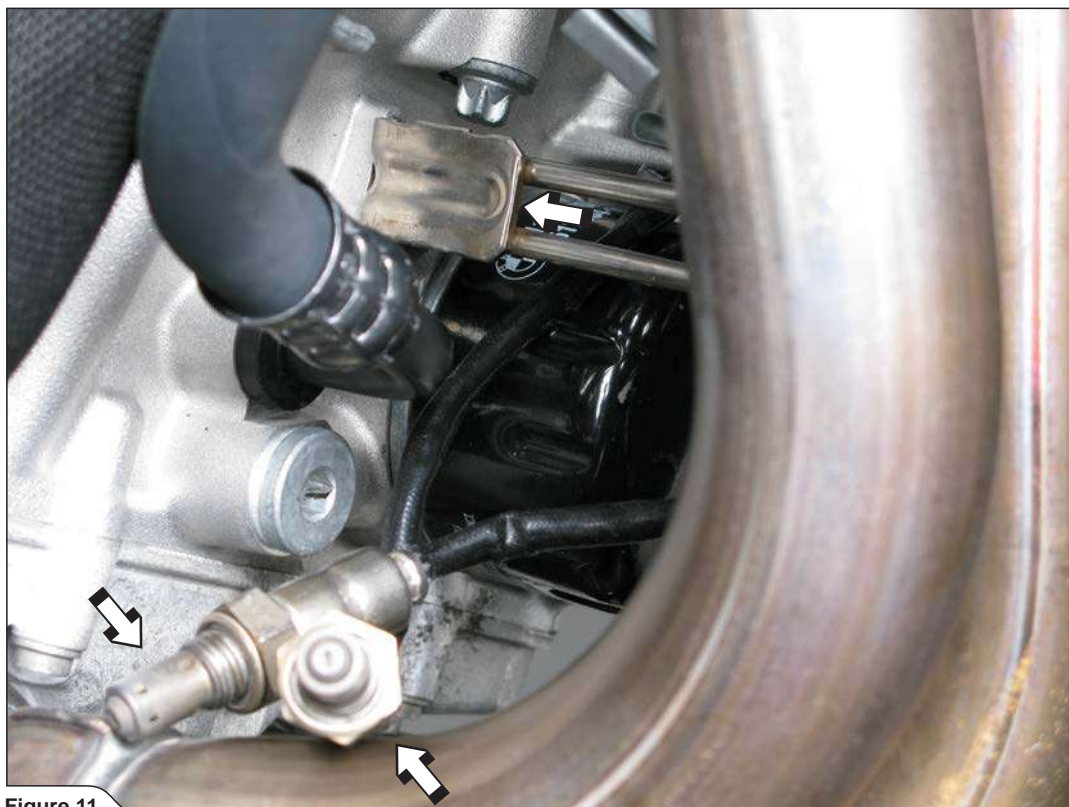

Figure 11

11. Remove the header tubes valve cable from servo motor (Figure 12).

! IMPORTANT: do not turn the the servo motor wheel with force or the servo motor could be damaged!

! IMPORTANT: do not disconnect the servo's electrical connector or remove the servo motor off the vehicle!

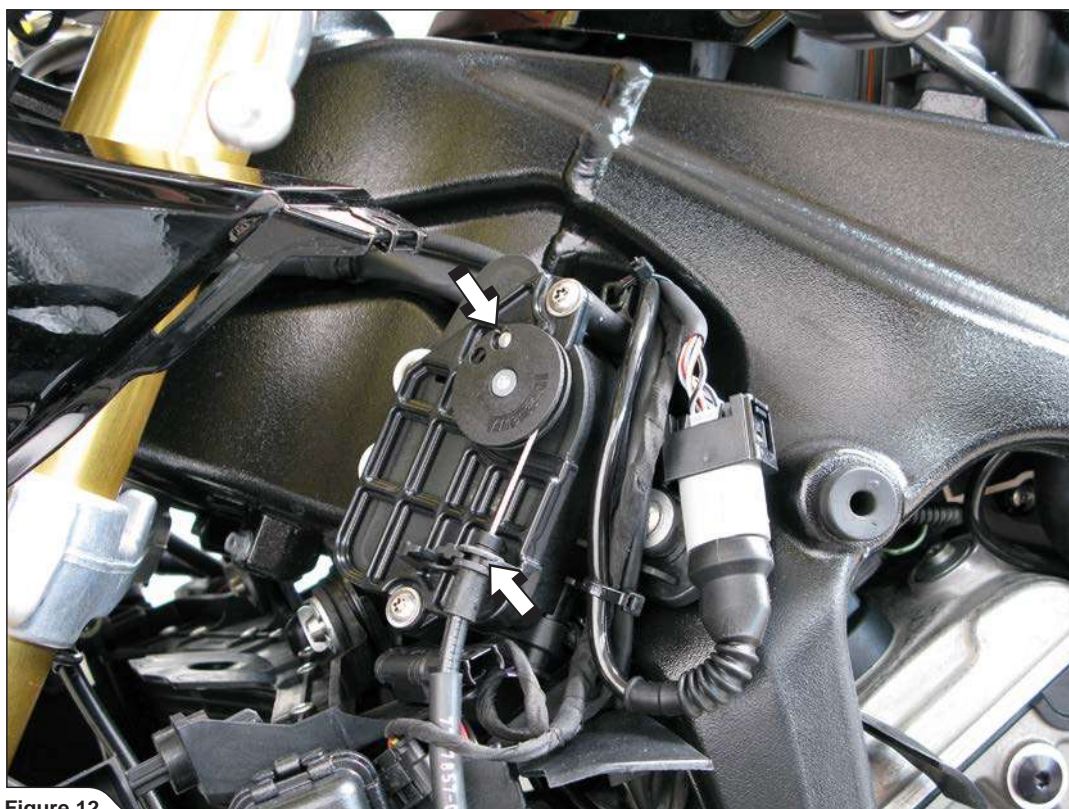

Figure 12

12. Unscrew all nuts from the front header tube flanges (Figure 13).

! **IMPORTANT:** make sure not to damage the radiator's cooling fins!



Figure 13

13. Unscrew the market bolt on both sides of the motorcycle and remove the stock exhaust off the motorcycle (Figure 14, 15).

! **IMPORTANT:** support the stock exhaust during this procedure or it may fall off and damage you or the motorcycle!



Figure 14



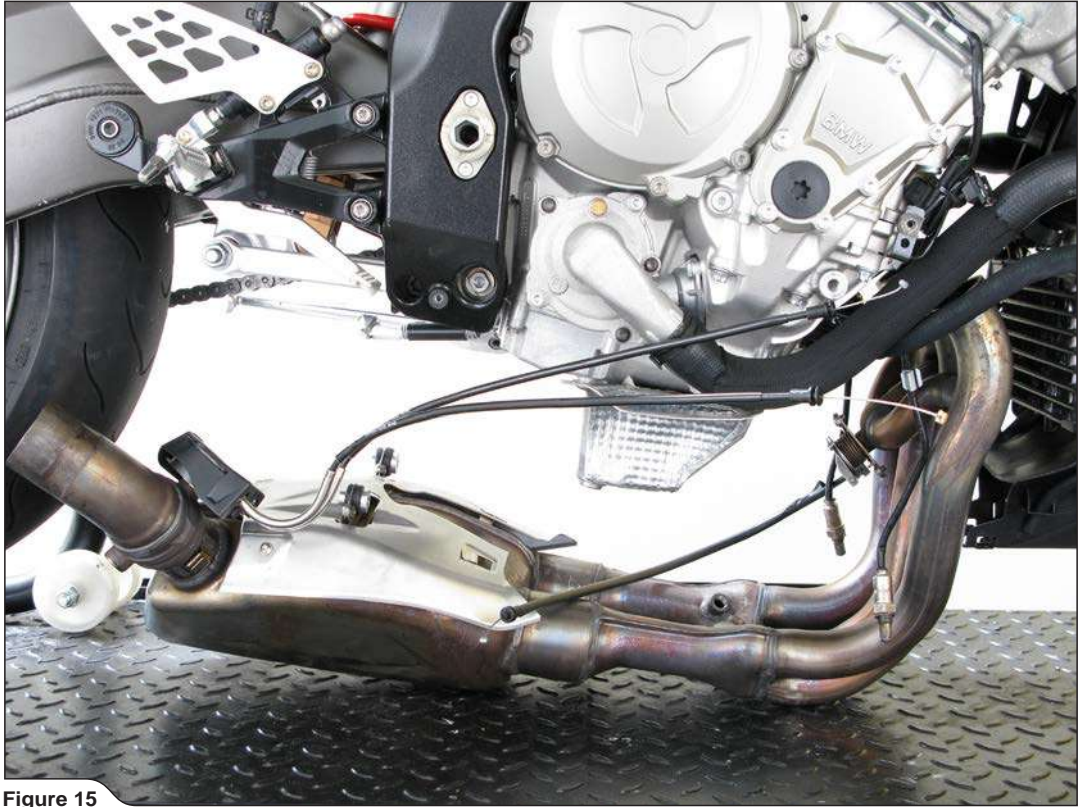

Figure 15

## INSTALLATION OF THE AKRAPOVIČ RACING OR EVOLUTION EXHAUST SYSTEMS:

1. Set up and hand tighten the sleeves together with the flanges and springs onto the cylinder head; make sure they are correctly oriented (Figure 16, 17).

**!** IMPORTANT: do not fully tighten the flanges yet!



Figure 16

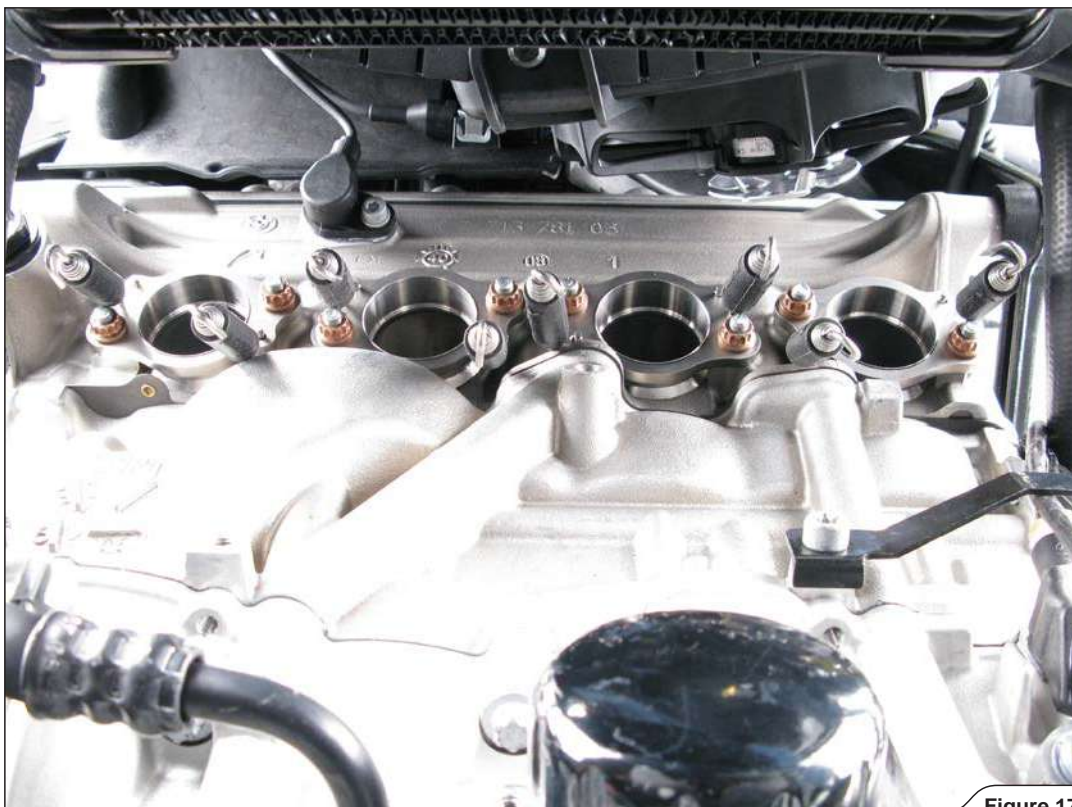

Figure 17



2. Insert the middle header tubes all the way into the sleeves together, attach the springs and tighten the middle flanges to a specified torque (**Figure 18**).

! **IMPORTANT:** use anti-seize copper paste on all nut threads!

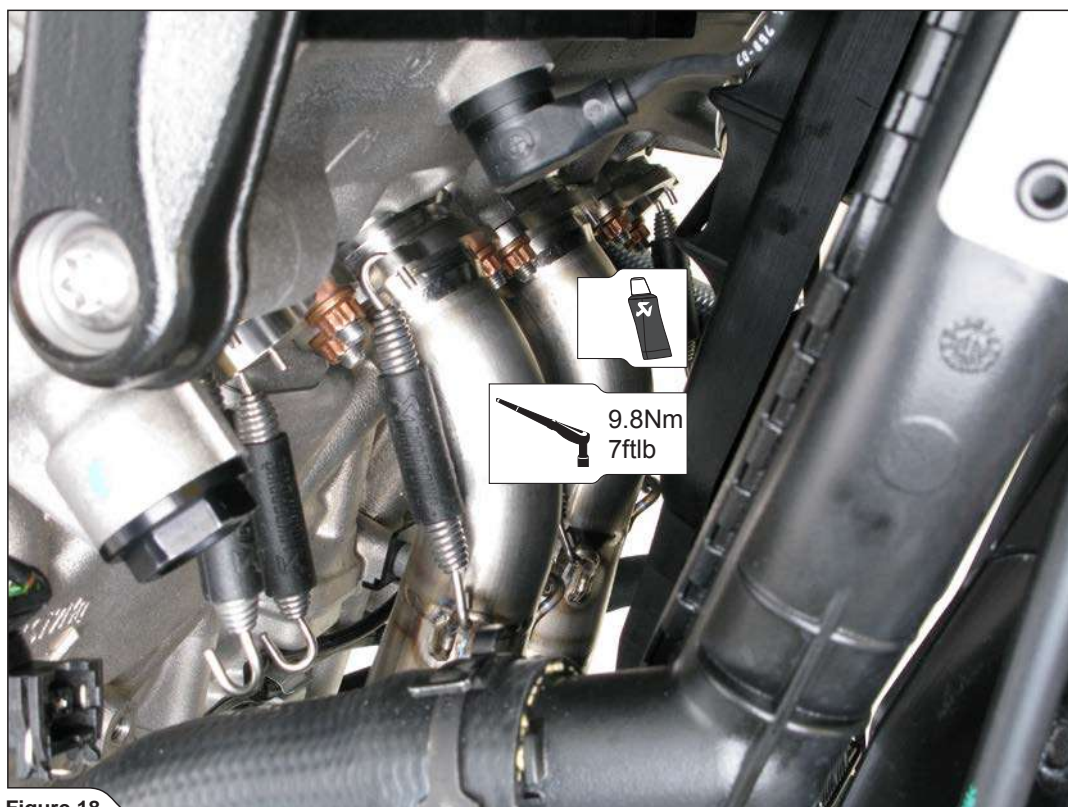

Figure 18

3. Tighten the lambda sensors into the middle header tubes and radiator bracket onto the cylinder block. Attach the sensor's electrical leads into the stock electrical lead brackets, as shown (**Figure 19**).

! **IMPORTANT:** grease only the threads of the lambda sensor with Akrapovič anti-seize lead-free copper paste!

! **IMPORTANT:** make sure not to damage the sensors' electrical leads during this procedure!

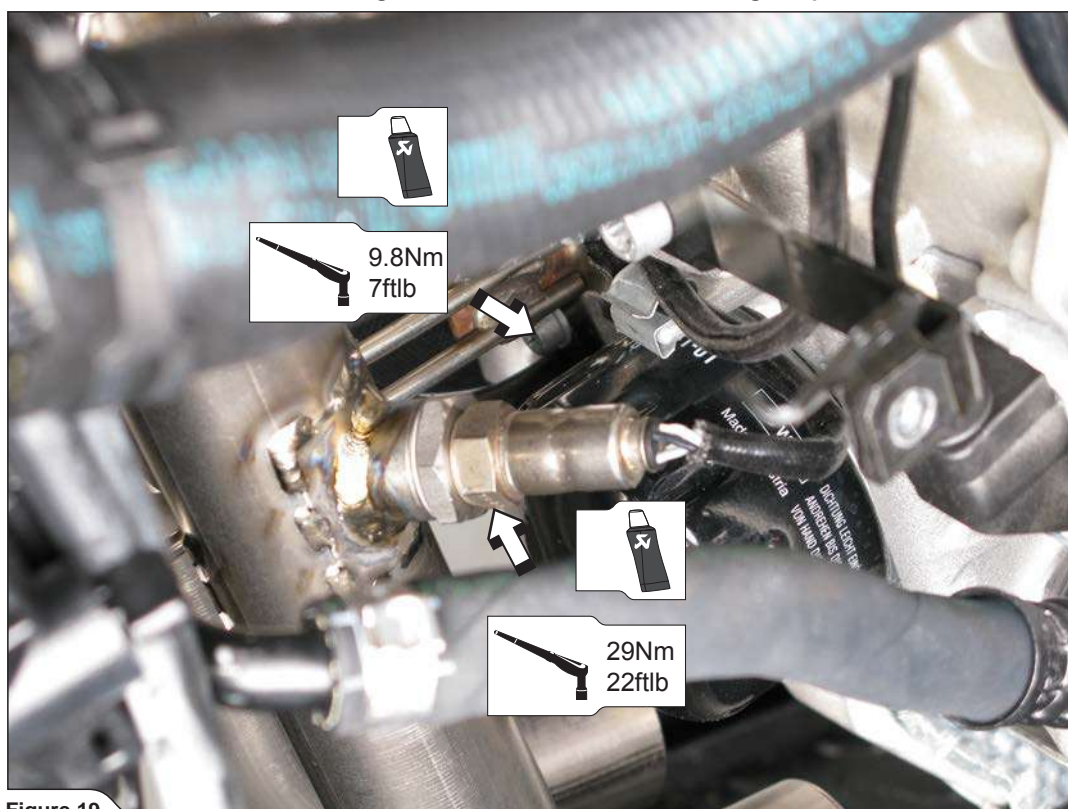

Figure 19

4. Attach the radiator bracket onto the radiators (**Figure 20**).

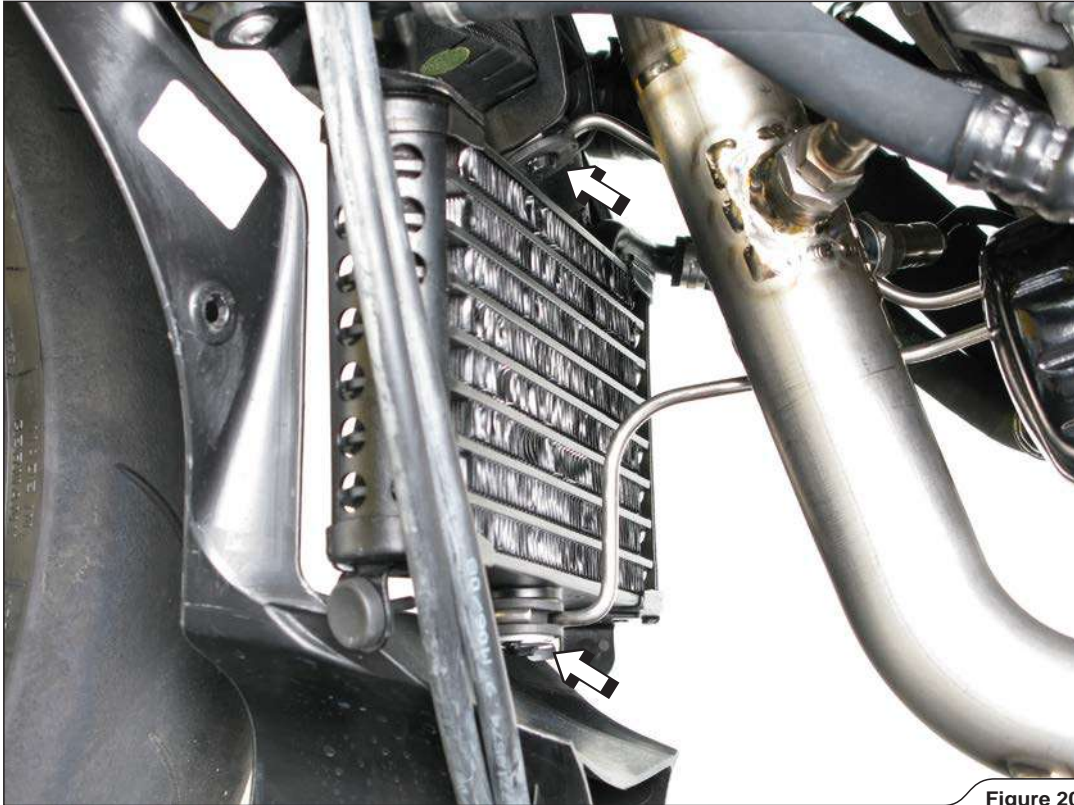

Figure 20

5. Insert the outer header tubes all the way into the sleeves, attach the springs and tighten the outer flanges to a specified torque (**Figure 21**).

**!** **IMPORTANT:** use anti-seize copper paste on all nut threads!

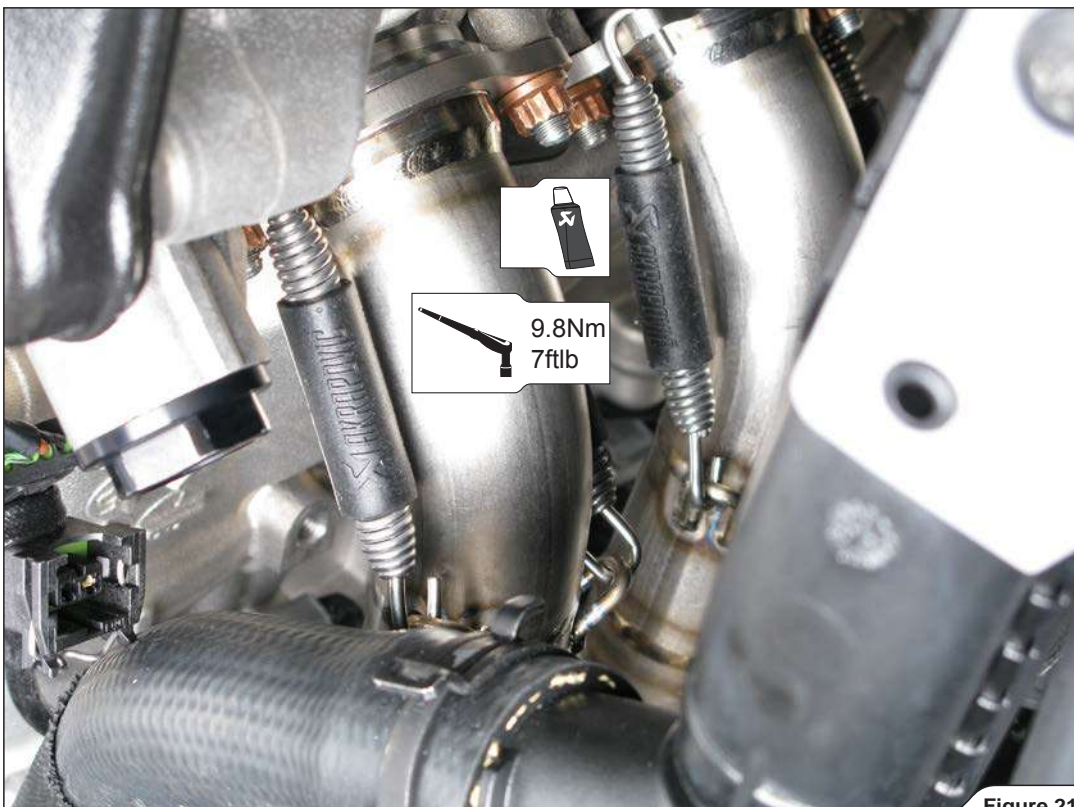

Figure 21



6. Assemble the collectors with link pipe as shown and attach the springs (Figure 22).  
! **IMPORTANT:** make sure, that springs pull the link pipe all the way onto the collectors – use rubber mallet if necessary to tap the connections into place!  
✂ **INSTALLATION TIP:** for Evolution exhaust sistem, coat the interior side of the input bushes of the titanium collector with Akrapovič ceramic anti-seizing grease(white tube).



Figure 22

7. Slide the assembled link pipe and collectors onto the header tubes and attach the springs (Figure 23).  
! **IMPORTANT:** make sure, that springs pull the collectors all the way onto the headers – use rubber mallet if necessary to tap the connections into place!  
✂ **INSTALLATION TIP:** for Evolution exhaust sistem, coat the interior side of the input bushes of the titanium collector with Akrapovič ceramic anti-seizing grease(white tube).

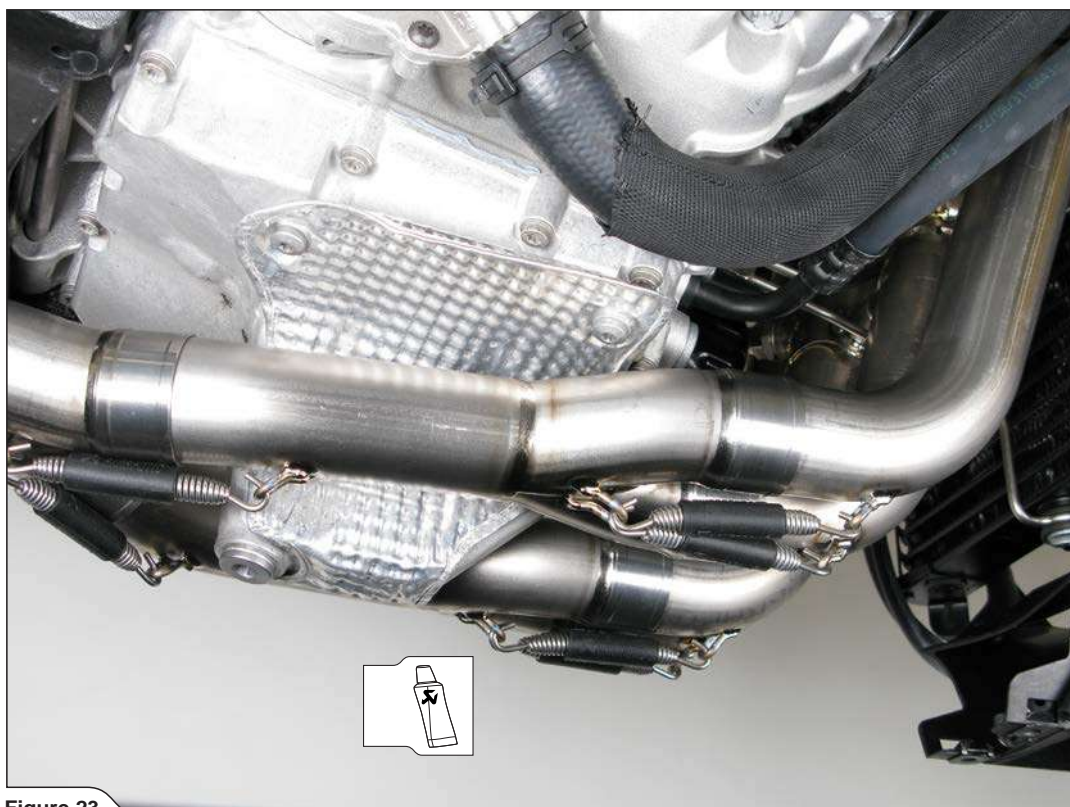

Figure 23

8. **For street legal Racing and Evolution only:** remove the stock exhaust cables off the stock exhaust valve and install them back onto the exhaust valve servo motor (**Figure 24**).

! **IMPORTANT:** make sure, that you don't swap the two cables!

! **IMPORTANT:** do not turn the the servo motor wheel with force or the servo motor could be damaged!



Figure 24

9. **For street legal Racing and Evolution only:** direct the exhaust valve cables to the Akrapovič exhaust valve (**Figure 25**).

! **IMPORTANT:** make sure, that you don't swap the two cables!



Figure 25



10. **For street legal Racing and Evolution only:** set the cable adjusters on the middle of the cable bracket, as shown. Tighten the cable adjusters nuts to a specified torque (**Figure 26**).

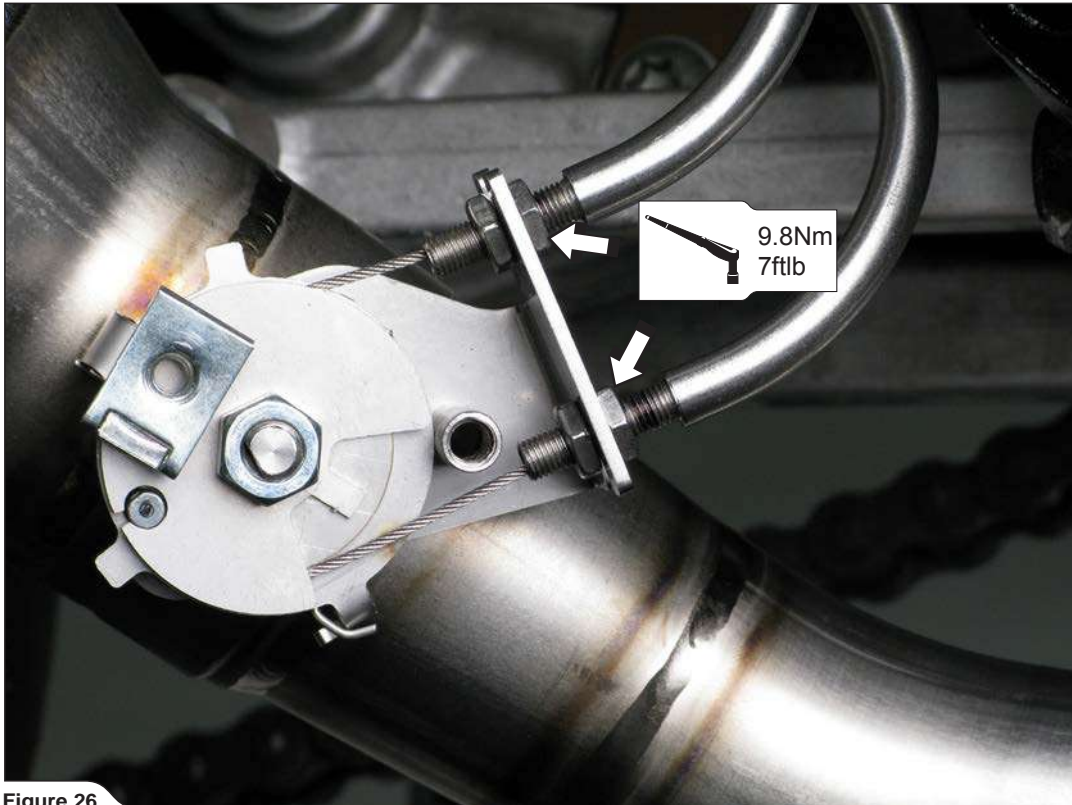

Figure 26

11. **For street legal Racing and Evolution only:** tighten the carbon-fiber heatshield onto the exhaust valve bracket, using Akrapovič bolts and heat resistant washers (**Figure 27**).

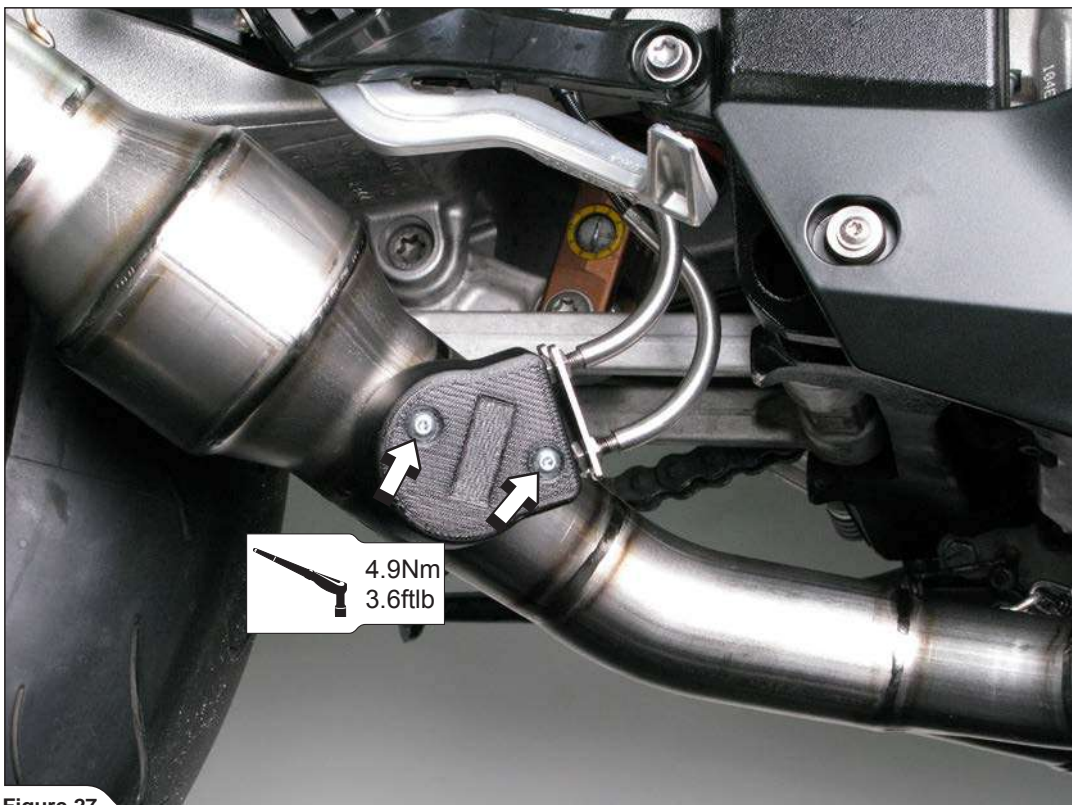

Figure 27

12. Attach the additional Akrapovič stainless steel bracket to the stock right passenger footrest bracket, using Akrapovič nut, bolt and washer (Figure 28, 29).



Figure 28

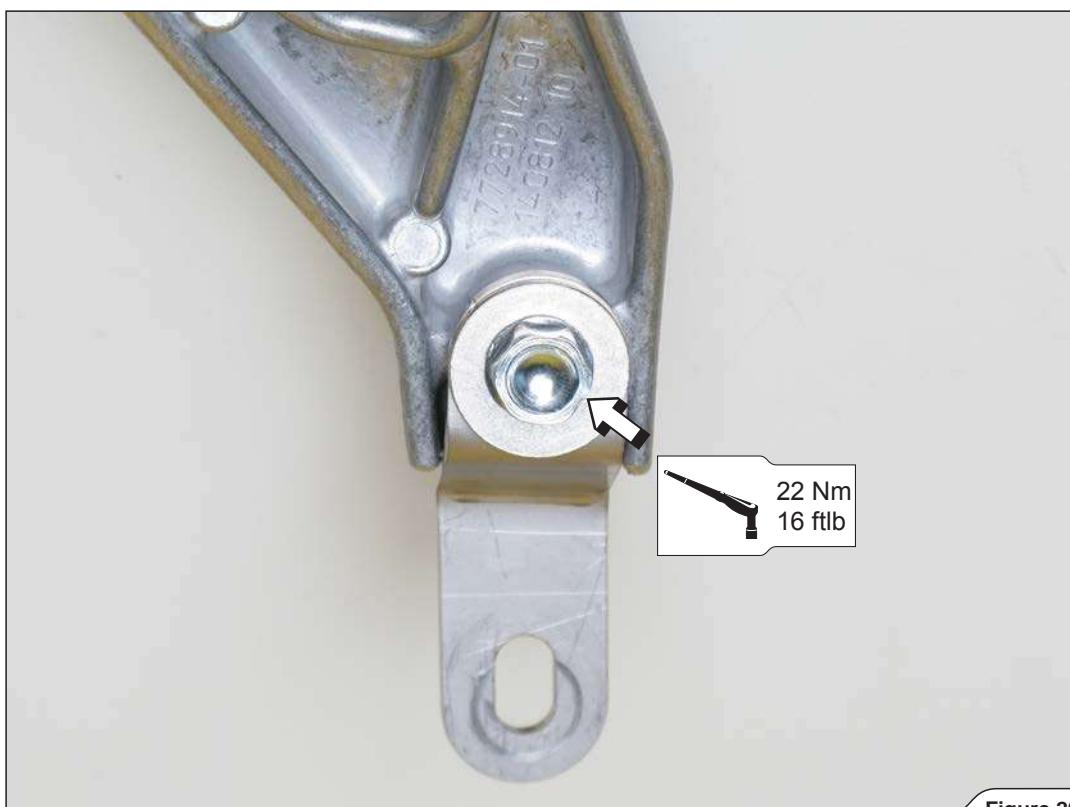

Figure 29



13. For optional carbon-fiber muffler bracket only: attach the optional Akrapovič carbon-fiber bracket as shown, using stock bolts (Figure 30).

! **IMPORTANT:** use anti-seize copper paste on bolt threads!

! **IMPORTANT:** do not carry passengers in case of installation of carbon fiber bracket!



Figure 30

14. Correctly position the carbon-fiber clamp and slide it onto the muffler - bear in mind the **left offset** of the carbon fiber clamp viewed from the rear (Figure 31).

! **IMPORTANT:** open the clamp slightly wider than the diameter of the outer sleeve of the muffler - do not scrape it along the muffler outer sleeve!



Figure 31

15. Position the muffler correctly and slide it onto the outlet side of the link pipe. Attach the springs (Figure 32).  
! **IMPORTANT:** make sure, that springs pull the muffler all the way onto the link pipe – use rubber mallet if necessary to tap the connection into place!  
✂ **INSTALLATION TIP:** for Evolution exhaust system, coat the interior side of the input bushe of the muffler with Akrapovič ceramic anti-seizing grease (white tube).



Figure 32

16. Align the muffler in respect to the motorcycle and tighten the muffler clamp to the bracket, using Akrapovič bolt, washers, and nut as shown (Figure 33).

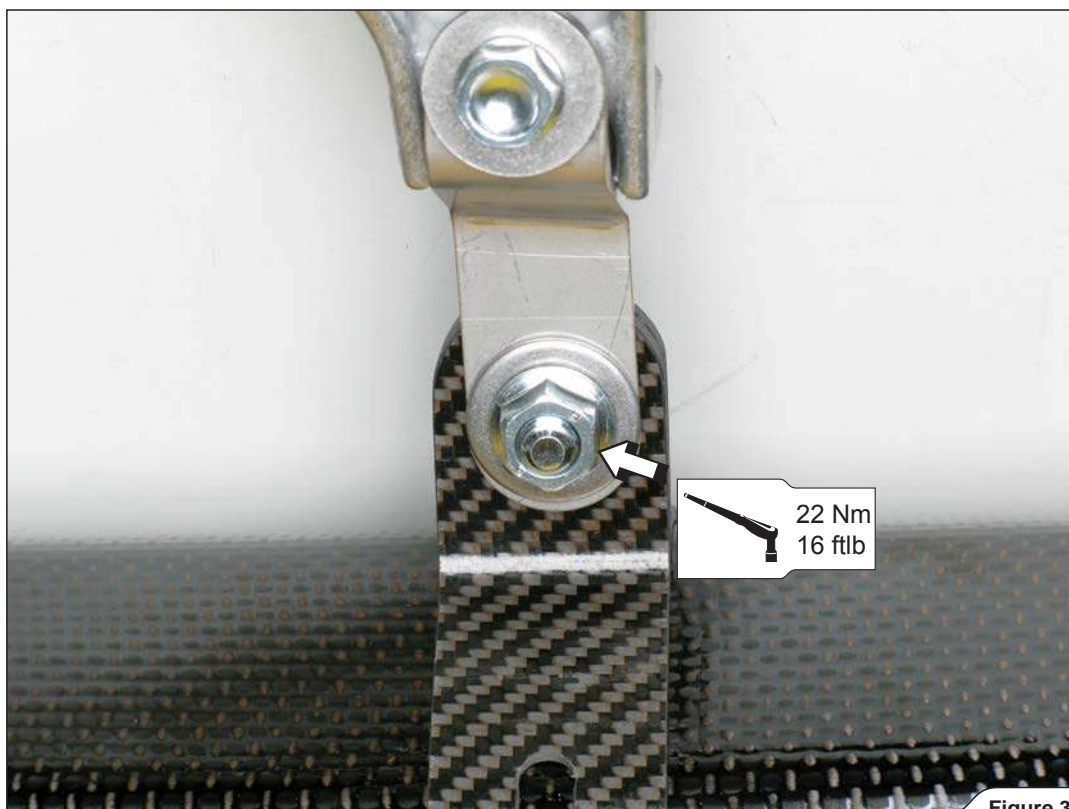

Figure 33



17. For optional carbon-fiber muffler bracket only: align the muffler in respect to the motorcycle and tighten the muffler clamp using Akrapovič bolt, washers and nut as shown (Figure 34).

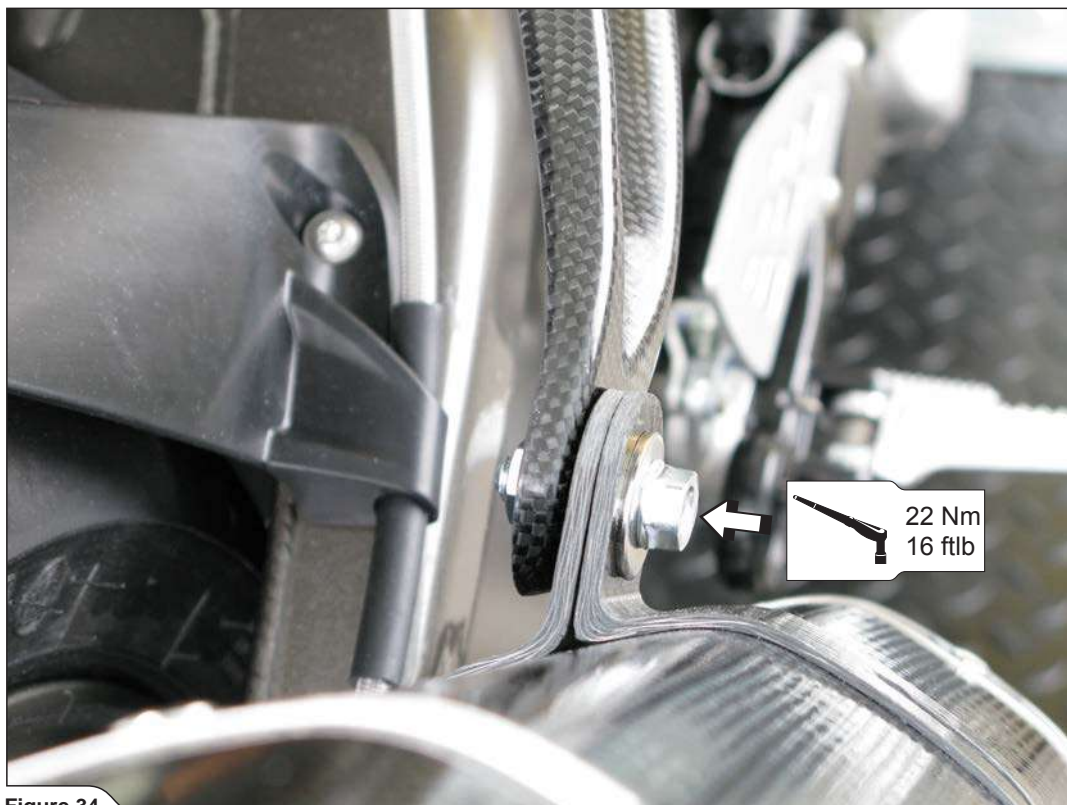

Figure 34

18. Assemble the cowlings in the reverse order from the order in which they were removed (Figure 35).  
**! IMPORTANT:** tighten all cowling bolts to a recommended torque or check vehicle manufacturer manual!



Figure 35

## **FINAL INSTALLATION AND MAINTENANCE:**

Clean grease spots off all exhaust system surfaces, when installation is finished. Cleaning will prevent spots from burning onto the surface. Do not use aggressive chemical cleaners, because they can damage the surface or sticker.

1. Muffler – titanium outer sleeve: use a soft cloth sprayed with a multi-purpose spray lubricant (WD-40® or equivalent)\*.
2. Muffler – carbon-fiber outer sleeve: use a soft dry cloth sprayed with all purpose foam cleaner, then wipe with a soft dry cloth.
3. Muffler – carbon-fiber outlet cap: use a soft dry cloth sprayed with all purpose foam cleaner, then wipe with a soft dry cloth.
4. Painted mufflers and parts – use a soft cloth sprayed with all purpose foam cleaner, then wipe with a soft dry cloth.
5. Chrome plated mufflers and parts: use a soft cloth sprayed with all purpose foam cleaner, then wipe with a soft dry cloth.
6. Stainless steel pipes: use a soft cloth sprayed with a contact cleaner, then wipe with a soft dry cloth.
7. Titanium pipes: use a soft cloth sprayed with a multi-purpose spray lubricant (WD-40® or equivalent)\*.

\*WD-40® is a trademark of the WD-40 Company.

**Periodically make sure all the bolts and springs are sufficiently tight.**



**IMPORTANT: make sure all the bolts are sufficiently tightened. In case the exhaust system touches the cowling or other parts repeat the adjustment of the exhaust system or contact your authorized dealer!**



**CAUTION: after running engine for 30 minutes, retighten the bolts of the Akrapovič carbon-fiber heat shield!**



**INSTALLATION TIP: IT IS NORMAL IF WHITE SMOKE COMES OUT OF THE MUFFLER DURING THE FIRST 100 KM AFTER REPLACEMENT.**



**INSTALLATION TIP: A CHANGE IN THE COLOR OF THE EXHAUST SYSTEM IS NORMAL DUE TO THE HIGH TEMPERATURES.**



**CAUTION: DO NOT STAND BEHIND THE MUFFLER AT ANY TIME.**



**IMPORTANT: DO NOT USE AUTOMOTIVE WHEEL CLEANERS OR ANY CLEANING PRODUCTS WHICH CONTAIN ACIDIC ADDITIVES TO CLEAN AKRAPOVIČ EXHAUST SYSTEMS.**



## TROUBLESHOOTING:

Problem	Possible cause	Solution
Exhaust gas leaks out of the muffler/pipe clamp connections	loosened clamp	tighten the clamp to specified torque
	connection is not completely joined	tap the connection into place and tighten the clamp to specified torque