



Installation instructions

Akrapovič Exhaust System:
Slip-On
for the
KAWASAKI ZX-10R

Congratulations on purchasing an Akrapovič exhaust system. Please read the entire installation manual prior to undertaking any activities related to installation of your new Akrapovič exhaust system. In case you do not fully understand the manual or any of its parts, please contact your authorized dealer!

This product should be installed by someone with sufficient knowledge of exhaust systems and their installation, and appropriate hand or power tools. If you are not qualified for this work, please utilize a certified mechanic for installation. By installing Your Akrapovič exhaust system, you indicate that you have read the installation manual in its entirety and you agree with the terms stated herein.

It is your responsibility to follow all installation instruction guidelines supplied with the Akrapovič exhaust system and undertake all necessary safety precautions. Akrapovič d.d. assumes no responsibility for damages occurring from misuse, abuse, improper installation, improper operation, lack of responsible care, or all previously stated reasons resulting from incompatibility with other manufacturer's products and/or systems.

IMPORTANT INFORMATION

Exclusion of Certain Liability

1. The manufacturer, importer or dealer shall not be liable for any incidental damage including personal injury or any other damages caused by improper installation or operation of the Akrapovič exhaust system. When installing the Akrapovič exhaust system be careful that the exhaust system does not touch other parts sensitive to high temperature.
2. Akrapovič makes no representation or warranties with regard to damage caused by the improper installation, use and maintenance of the Akrapovič exhaust system. The warranty is limited to defects recognized by our technical department and due to normal use, and excludes items subject to normal wear (gaskets and damping wool). The guarantee is void in case of accident, modification, improper or competition use.
3. Do not attempt to install the Akrapovič exhaust system on a vehicle model for which it was not made or tested by Akrapovič.
4. When the exhaust system gets very hot during operation, be careful not to burn yourself on the exhaust system or parts which are in direct contact with it, even when the engine is not running. Also protect other people, especially children, from the injuries mentioned above.
5. In some cases Akrapovič exhaust system kits contain chemical products (ceramic anti-seizing grease; bolt sealant). Handle with care, do not inhale or swallow. Avoid excessive contact with skin, eyes or mucous membranes. Keep out of reach of children.
6. Technical specifications of Akrapovič exhaust systems and related products are subject to change without notice.
7. Before removing the original exhaust system from your vehicle, please compare the parts you received with the list of materials provided in the installation manual in order to assure that you have all the parts necessary for the installation of your new Akrapovič exhaust system.
8. Although this manual consists of instructions for installation in written form, as well as photographs and pictures representing individual steps of the installation, please note that the photographs and pictures are symbolic and are intended for representation of general overview only. The photographs and pictures contained herein should serve as a guideline only and actual installation of the exhaust system may not correspond with the photographs and pictures entirely.
9. The process of uninstalling the original exhaust system may vary depending on the existing exhaust system. Please follow the original exhaust system manufacturer's instructions for uninstalling the original exhaust system.

Symbols

The following symbols are used throughout these installation instructions:



TOOLS REQUIRED



TIGHTENING TORQUE



INSTALLATION TIP



CAUTION OR WARNING



USE BOLT SEALANT; Apply 3 to 4 small drops of bolt sealant onto the cleaned and degreased threads before tightening the bolts. **WARNING! Avoid contact with skin, eyes and mucous membranes. Do not inhale fumes. Keep out of reach of children.**



USE ANTI-SEIZE LEAD-FREE COPPER PASTE (black tube); Provides trouble-free and long-lasting protection against seizing, corrosion and rusting of bolts, threaded ends, nuts, joints, etc. Also protects against vibration, wear and impact. **WARNING! Avoid eye contact. Avoid excessive skin contact. Keep out of reach of children.**



USE ANTI-SEIZING GREASE (white tube); Prevents seizing, corrosion and excessive wear between the titanium components of your exhaust system. **WARNING! Avoid eye contact. Avoid excessive skin contact. Keep out of reach of children.**



T-handle 8mm wrench
T-handle 10mm wrench
T-handle 4mm three hexagon wrench
T-handle 6mm three hexagon wrench
T-handle 5mm swivelling three hexagon wrench
Combination 10mm wrench
Combination 12mm wrench
Combination 15mm wrench
Combination 17mm wrench
Flat screwdriver



BEFORE INSTALLING, CHECK SCHEMATIC OF THE EXHAUST SYSTEM!



IF ANY ITEMS IN THE AKRAPOVIČ EXHAUST SYSTEM PACKAGE ARE MISSING, PLEASE CONTACT YOUR AUTHORIZED DEALER. KEEP THE SCHEMATIC FOR FUTURE REFERENCE.



THESE INSTALLATION INSTRUCTIONS MUST BE READ CAREFULLY IN ORDER TO ENSURE PROPER INSTALLATION AND OPERATION OF THE AKRAPOVIČ EXHAUST SYSTEM.



THE EXHAUST SYSTEM CAN BE EXTREMELY HOT. ALLOW THE EXHAUST AND ENGINE TO COOL DOWN BEFORE BEGINNING INSTALLATION.



WE ADVISE YOU TO LEAVE INSTALLATION TO A QUALIFIED SERVICEMAN. IMPROPER INSTALLATION MAY RESULT IN A SHORTER LIFETIME OF THE EXHAUST SYSTEM AND/OR DAMAGE TO THE VEHICLE.

REMOVAL OF ORIGINAL EXHAUST SYSTEM:

1. Put the motorcycle on a side stand, we recommend a racing stand.
2. Unscrew the original heat-shield. Unscrew marked bolts from the muffler hanging bracket and the metal clamp at the muffler-collector connection (**Figure 1**). Remove the muffler off the motorcycle.



Figure 1

3. For optional link pipe only: unscrew and remove the exhaust valve shield (**Figure 2**).

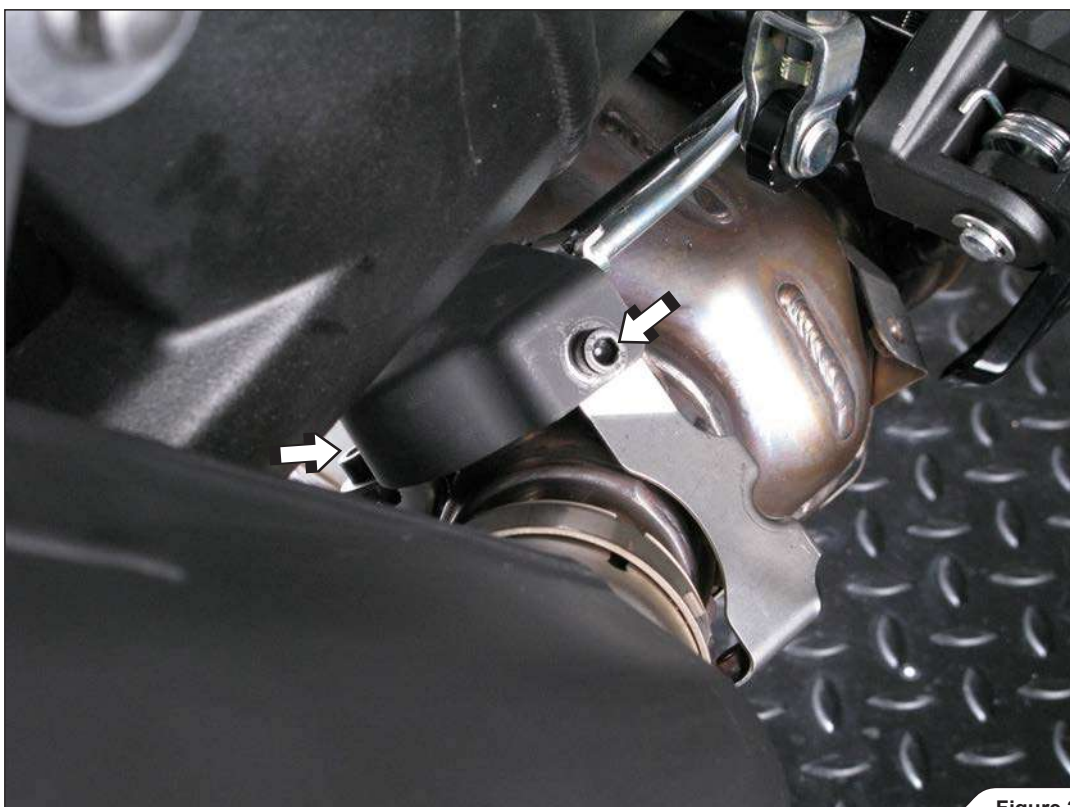

Figure 2

4. For optional link pipe only: remove the passenger's seat, unscrew the seat cowling and rider's seat (Figure 3, 4).
! **WARNING:** make sure, not to damage any part of the motorcycle during this process!



Figure 3



Figure 4

5. For optional link pipe only: shorten the cable adjusters, remove the safety pin and cables off the servo motor (Figure 5).

! **WARNING:** do not disconnect the servo motor's electrical connector or remove the servo motor off the vehicle!
! **WARNING:** do not turn the servo motor wheel with force, or it could damage!

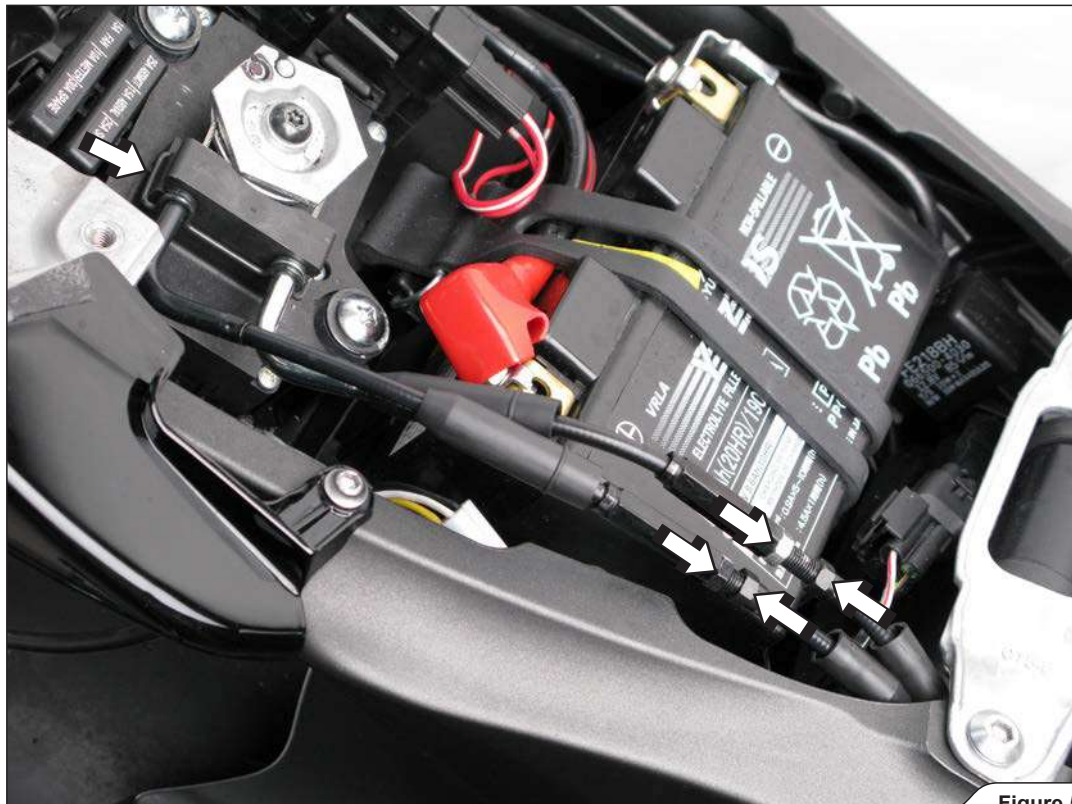

Figure 5

6. For optional link pipe only: unscrew the foot peg and foot guard, to release the exhaust valve cables (Figure 6).

! **WARNING:** make sure, not to damage any part of the motorcycle during this process!

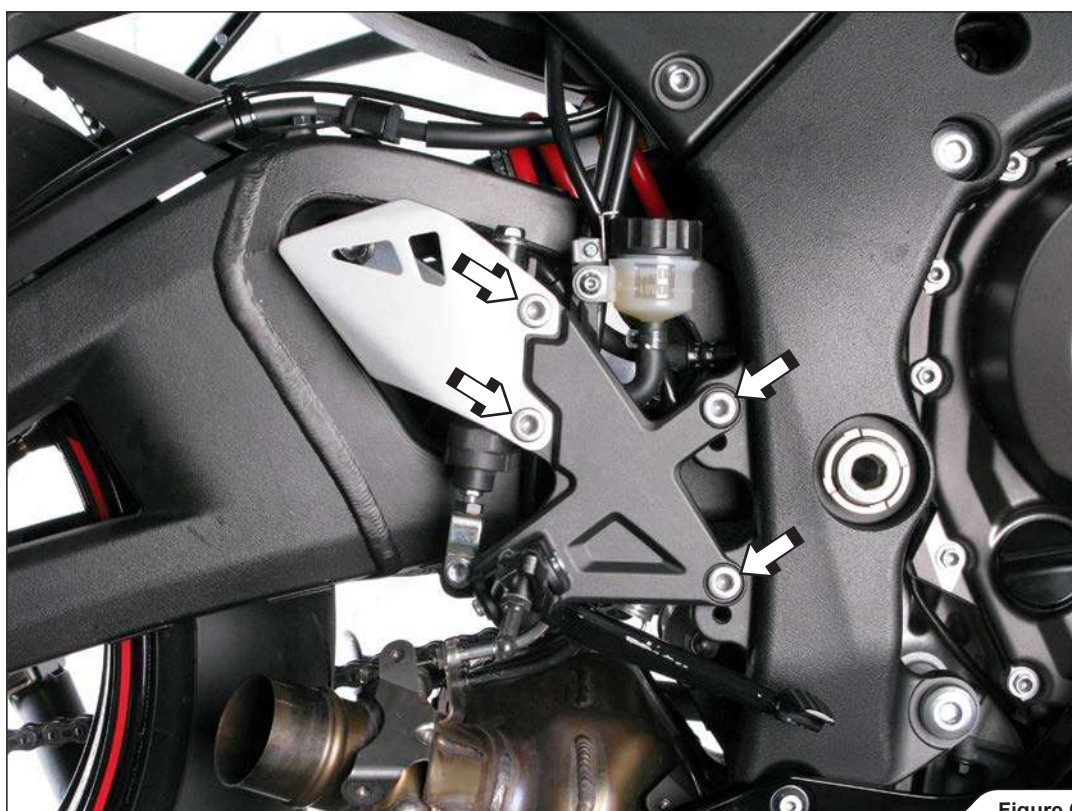

Figure 6

7. **For optional link pipe only:** unscrew the two marked bolts and partially remove the cowling (Figure 7).
! WARNING: make sure, not to damage any part of the motorcycle during this process!

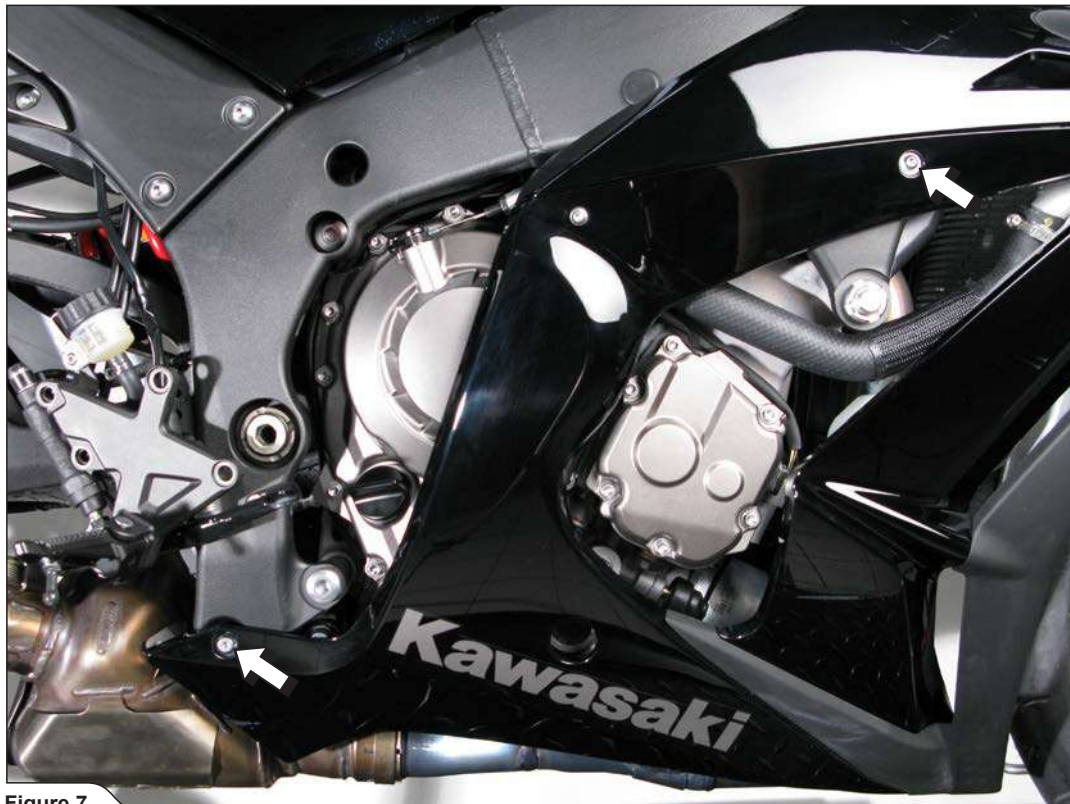

Figure 7

8. **For optional link pipe only:** untighten metal clamp at the collector-headers connection and unscrew the collector hanging bracket and the lambda sensor (Figure 8). Remove the collector together with exhaust valve cables off the motorcycle.
! WARNING: be careful not to damage any part of the motorcycle, during this process!



Figure 8

INSTALLATION OF THE AKRAPOVIČ EXHAUST SYSTEM:

1. For optional link pipe only: assemble the foot peg and foot guard back onto the frame (Figure 9).

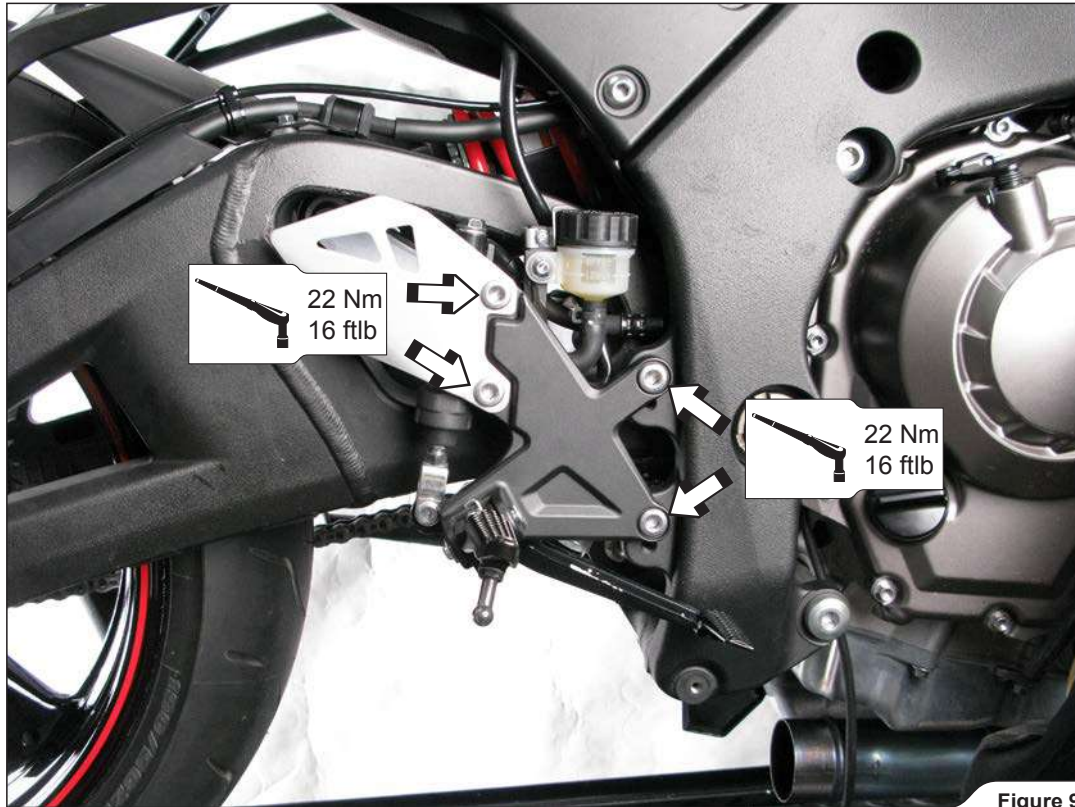

Figure 9

2. For optional link pipe only: install the metal clamp (R10) onto the muffler inlet bush as shown (Figure 10).
! WARNING: use anti-seize copper paste on bolt threads and interior of the clamp!



Figure 10

3. **For optional link pipe only:** install the metal clamp (R25) onto the optional link pipe inlet bush, as shown (Figure 11).
! **WARNING:** use anti-seize copper paste on bolt threads and interior of the clamp!



Figure 11

4. **For optional link pipe only:** slide the optional link pipe all the way onto the original headers and align it in respect to the motorcycle. Tighten the link-pipes' bracket onto the frame (using bolt and nut from installation kit), lambda sensor and metal clamp to a specified torques (Figure 12).
! **WARNING:** make sure, not to damage lambda sensor's electrical lead during this process!

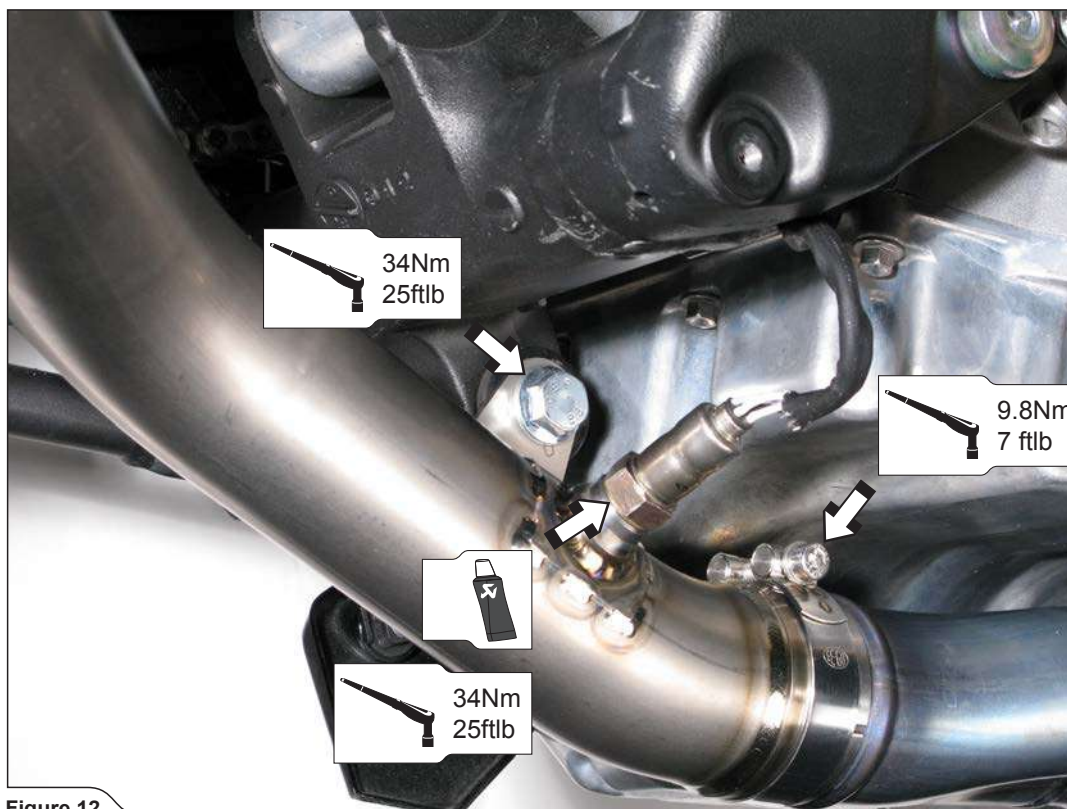

Figure 12

5. **For optional link pipe only:** reinstall the engine cowling, seats and seat cowling in reverse order in which they were removed (Figure 13, 14, 15).

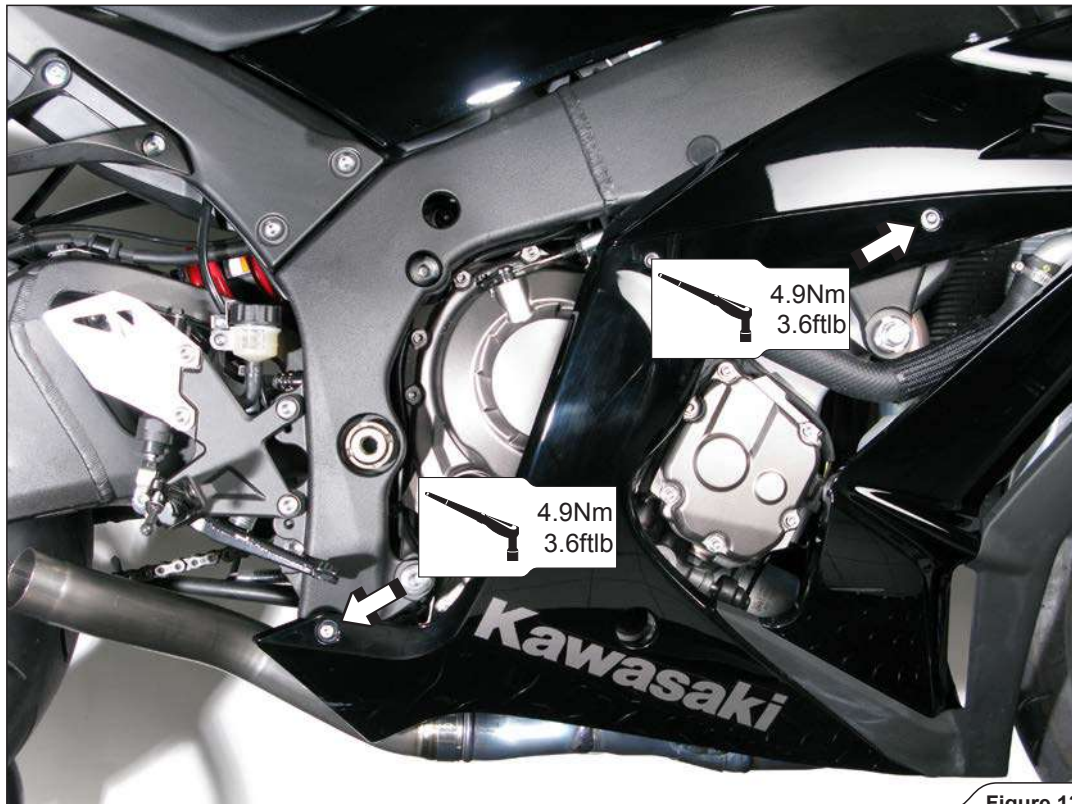

Figure 13

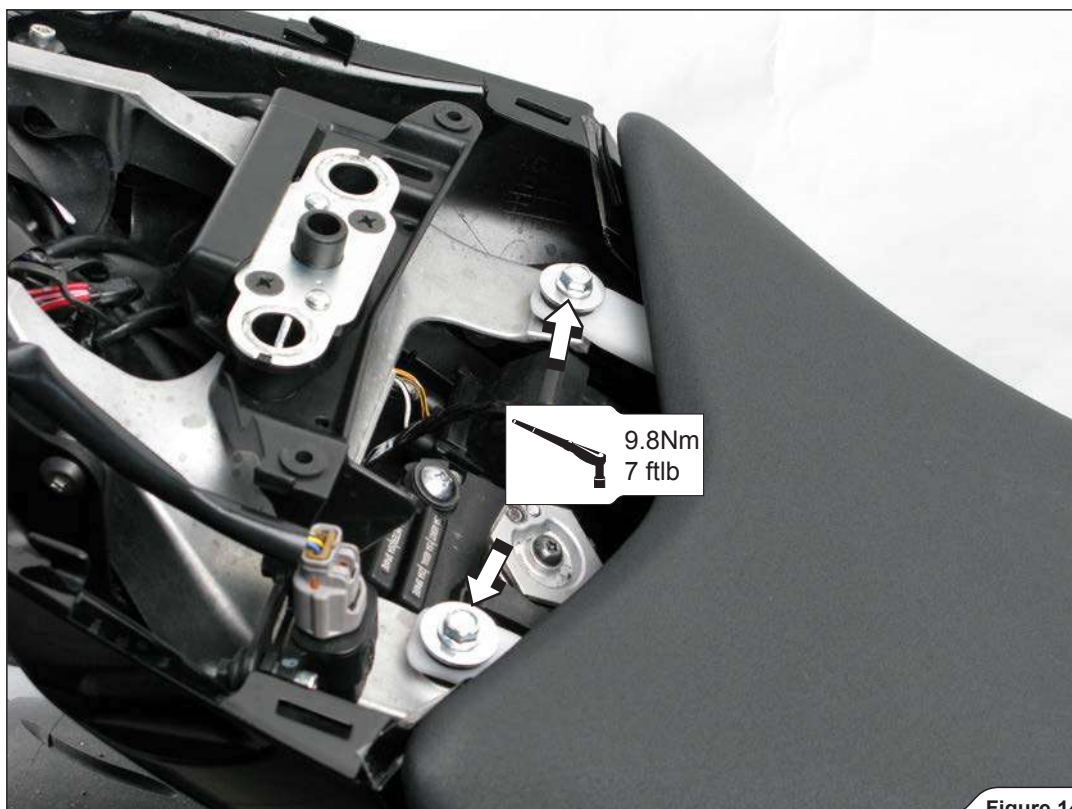

Figure 14



Figure 15

6. **For optional link pipe only:** slide the muffler onto the outlet side of the link pipe. Align the muffler in respect to the motorcycle and tighten the muffler bracket onto the passengers foot rest (using original bolt and nut) and metal clamp to the specified torques (**Figure 16**).

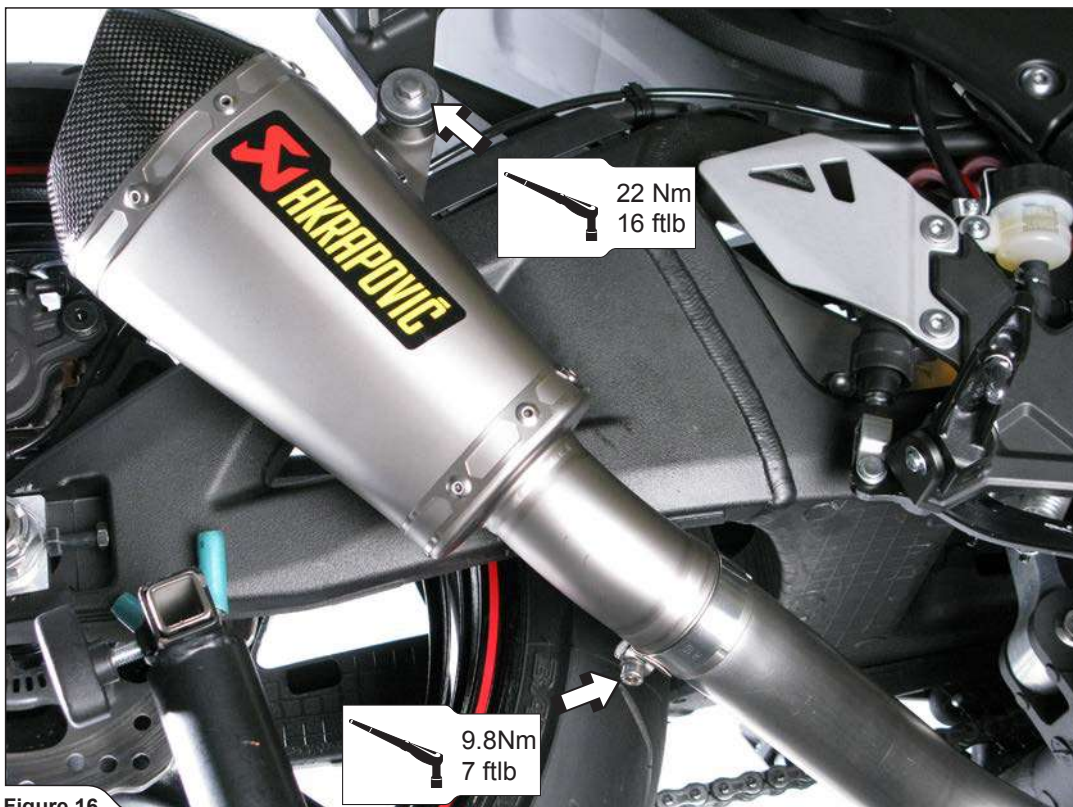

Figure 16

7. Install the metal clamp (R10) onto the muffler inlet bush and heat-shield bracket as shown (Figure 17).
! **WARNING:** use anti-seize copper paste on bolt threads and interior of the metal clamp!
! **WARNING:** hand tighten the tape clamp only!



Figure 17

8. Correctly assemble the bolts and heat resistant washers onto the carbon fiber heat-shield, as shown (Figure 18).
✘ **INSTALLATION TIP:** screw the heat resistant washers onto the bolts; do not try to push them on!

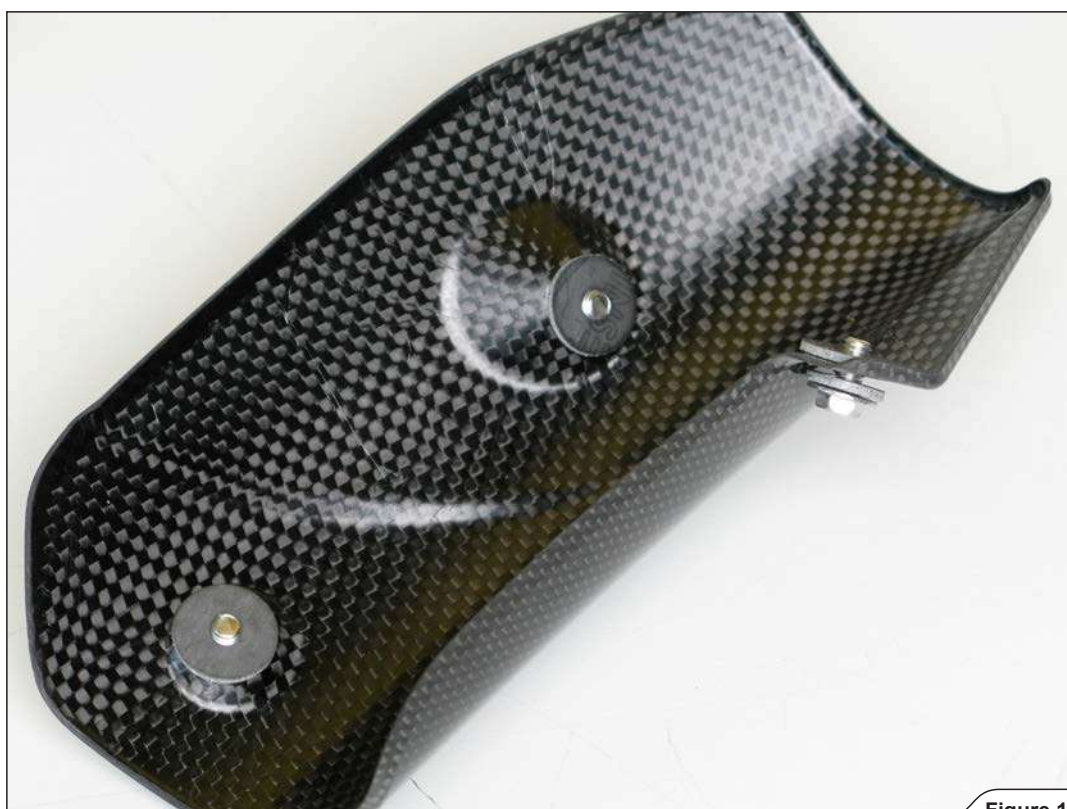

Figure 18

9. Slide the muffler onto the outlet side of the collector (Figure 19).

✂ **INSTALLATION TIP:** in case, the muffler bracket's hole doesn't align with original muffler mounting point, please refer to point 10. - figure 20.



Figure 19

10. In case, the muffler bracket's hole doesn't level with original muffler mounting point, untighten metal clamp at the collector-headers connection and collector hanging bracket. Adjust the collector together with Akrapovič muffler, until the muffler bracket aligns with original muffler mounting point. Retighten the metal clamp at the collector-headers connection and collector hanging bracket to the specified torques (Figure 20).

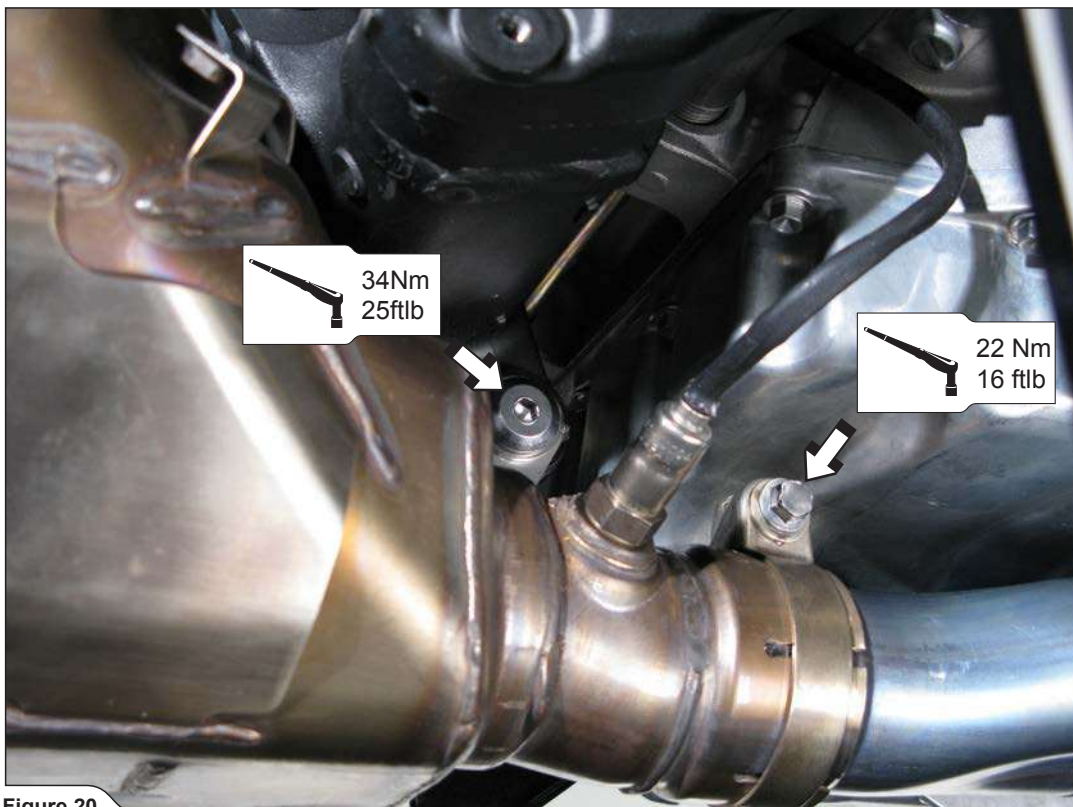
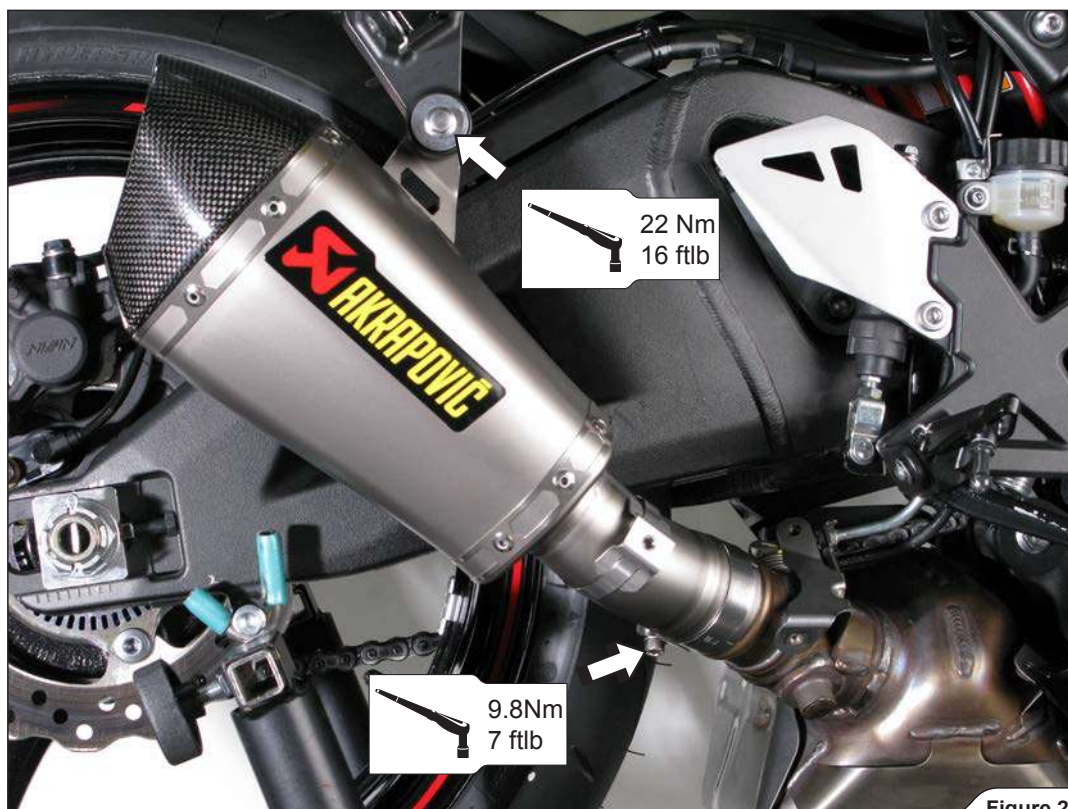

Figure 20

11. Align the muffler in respect to the motorcycle and tighten the muffler bracket onto the passengers foot rest (using original bolt and nut) and metal clamp to the specified torques (**Figure 21**).



12. Install carbon fiber heat-shield, as shown (**Figure 22, 23**).





Figure 23

13. Tighten the heat-shield bracket's tape clamp to the specified torque (**Figure 24**).

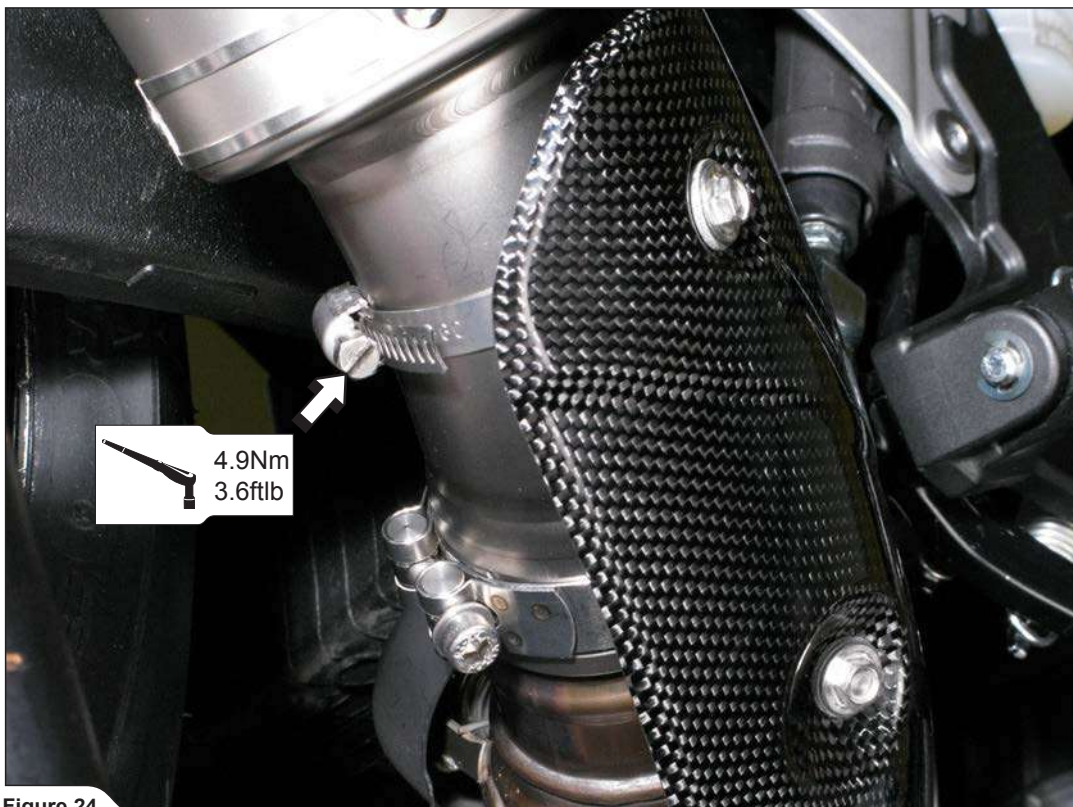

Figure 24

Final installation:

Clean grease spots:

- a. Muffler – carbon-fiber outer sleeve: use a soft dry cloth.
- b. Muffler – titanium outer sleeve: use a soft cloth sprayed with a multi-purpose spray lubricant (WD-40 or equivalent).
- c. Muffler – carbon-fiber outlet cap: use a soft dry cloth.
- d. Titanium link pipe: use a soft cloth sprayed with a multi-purpose spray lubricant (WD-40 or equivalent).

Cleaning will prevent spots from burning onto the surface. Do not use aggressive chemical cleaners, because they can damage the sticker.

! WARNING: make sure all the bolts are sufficiently tightened. In case the exhaust system touches the cowling or other parts repeat the adjustment of the exhaust system or contact your authorized dealer.

! WARNING: check vehicle manufacturer manual for tightening torques (for dismantled stock parts)!

! IT IS NORMAL IF WHITE SMOKE COMES OUT OF THE MUFFLER ON FIRST OPERATION.

! DO NOT STAND BEHIND THE MUFFLER ON FIRST OPERATION.

! DO NOT USE AUTOMOTIVE WHEEL CLEANERS OR ANY CLEANING PRODUCTS WHICH CONTAIN ACIDIC ADDITIVES TO CLEAN AKRAPOVIČ EXHAUST SYSTEMS.

FOR SLIP-ON WITH OPTIONAL LINK PIPE ONLY:

! WARNING: Akrapovič SLIP-ON exhaust system with OPTIONAL LINK PIPE for Kawasaki ZX-10R, is RECOMMENDED to be used in combination with ECU fuel mapping enrichment, otherwise you risk severe engine damage!

MAINTENANCE OF THE AKRAPOVIČ EXHAUST SYSTEM:

1. Clean the titanium exhaust components with a multi-purpose spray lubricant (WD-40 or equivalent), carbon fiber exhaust components with soft and dry cloth and stainless steel components with soft cloth sprayed with contact cleaner, then wipe with soft and dry cloth. A change in the color of the exhaust system is normal due to the high temperatures.
2. Periodically make sure all the bolts and springs are sufficiently tight.

Kawasaki ZX-10R/ SLIP-ON exhaust system / EC Type approval
Product code: S-K10SO7T-HASZ

WARNING! IN CASE OF COMBINATION WITH OPTIONAL LINK PIPE, MUFFLER EC TYPE APPROVAL IS NOT VALID!

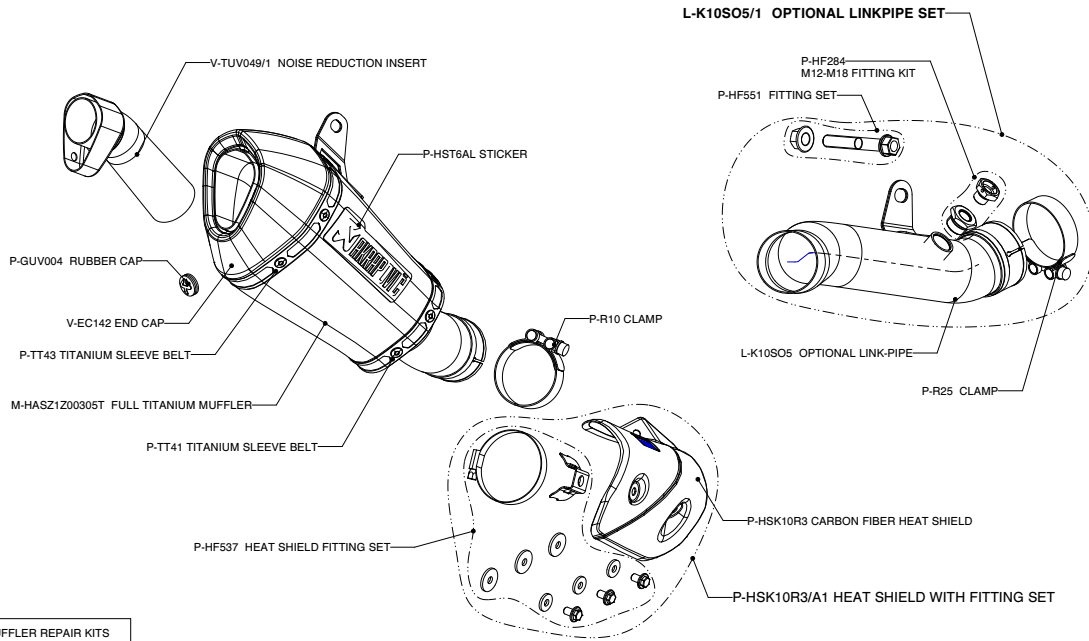

MUFFLER REPAIR KITS	
REPACK	P-RPCK5
SLEEVE	P-RKS307ASZ19