



## MOUNTING INSTRUCTIONS FOR 993-190 TRUNK RELOCATION KIT for GL1100

Note: Read instructions thoroughly before installing. Drilling required.

1. Place bike on center stand.
2. Remove trunk and lid. Using a 12mm wrench, remove the lock plungers.
3. Rotate the front hinges so that the “U” parts face each other.
4. Place the trunk upside down and place the relocation bracket on the bottom of the trunk with the front edge even with the front edge of the trunk. Mark the 4 holes through the screw thread insert.
5. Drill four 9/32 holes in the bottom of the trunk.
6. Remove the two left screws from the trunk locks. Place the trunk re-locator on the luggage rack and install the two 6x45mm bolts through the locator and into the trunk locks.
7. Drill two 9/32 holes in the front cross bar of the luggage rack.
8. Place the spacers between the rack and locator. Bolt together with the 6x40mm bolts and nuts provided.
9. Place trunk on top of the locator and bolt through drill holes with 6x30mm bolts.
10. Double check for tightness and reinstall trunk lid.

**CAUTION:** Due to the unique vibrations created by the operation of the motorcycle, the manufacturer recommends periodic inspection of accessories to secure mounting as indicated as above. Operator should not overload or abuse the product as insecure mounting may result.

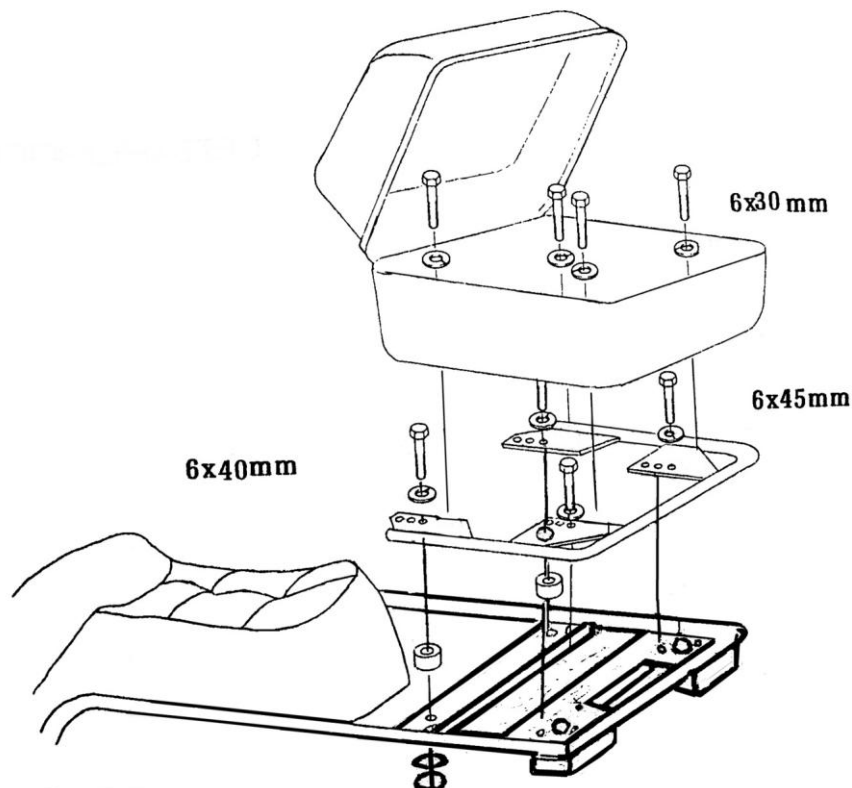



## MOUNTING INSTRUCTIONS FOR 993-190 TRUNK RELOCATION KIT for GL1200 Fits 84-87 Interstate, Aspencade, LTD and SEI

Note: Read instructions thoroughly before installing. Drilling required.

1. Place bike on center stand.
2. Remove the four mounting screws from inside of the trunk and save.
3. Carefully, tip the trunk forward and rest on the passenger seat. The trunk's wiring harness may need to be disconnected to do this.
4. Chose one of the three mounting positions and attach the frame to the Gold Wing with spacers as shown. (Note: Three mounting holes provided different positioning. The forward most hole offers a 2 inch rearward relocation of the trunk, while the rear most hole offers 1 inch.)
5. Place the trunk on the frame and reconnect the wiring harness if necessary. Make sure wires do not get pinched.
6. Fasten the trunk to the threaded holes provided in the relocation frame with the stock mounting screws removed in Step 2 and lock washers as shown.
7. Make sure the trunk is secure and that all lights are working properly.

**CAUTION:** Due to the unique vibrations created by the operation of the motorcycle, the manufacturer recommends periodic inspection of accessories to secure mounting as indicated as above. Operator should not overload or abuse the product as insecure mounting may result.

Parts List	
Qty	Description
1	Relocation Frame
4	M6 x 30mm Screws
8	M6 Lock Washers
4	5/8" Long Spacers

