



# INSTALLATION INSTRUCTIONS FOR 15673-629 GL1500 CB ANTENNA

Rev 8-11

NOTE: Read instructions thoroughly before installing.

**Place bike on center stand to prepare the motorcycle for installation of the antenna.**

1. Remove: Seat, Left Trunk Pocket, and Left Trunk Side Trim according to service manual instructions.

## Installing Antenna - Diagram A

1. Using the supplied template (3 1/2" long by 1" wide) as a guide and drill two (2) 17mm (11/16") holes and one (1) 12mm (1/2") hole in the left trunk side trim.

2. Re-install the left trunk side trim then route the antenna coax through the 12mm (center) hole and mount the antenna using the two (2) 16mm long flange bolts (A) and lock washers (B) and wire clips (C), supplied in the kit.

3. If your motorcycle doesn't have the antenna lead built into the main harness you will need to route the supplied antenna lead along the main harness, as shown in **Diagram B**. Secure with supplied wire ties and clips.

## Installing the Ground Plate - Diagrams C1 and C2

1. Remove the two (2) acorn nuts (A), and flat washers (B) from the back wall of the trunk and the stock bolt (C) from the bottom of the trunk.

2. Install the ground plate as shown in **Diagram C2**, using the hardware supplied in the kit. Acorn nuts (A), lock washers (B) and flat washers (C) and the 25mm long flange bolt (D) and flat washer (E).

3. Re-install the left trunk pocket and seat.

DIAGRAM A

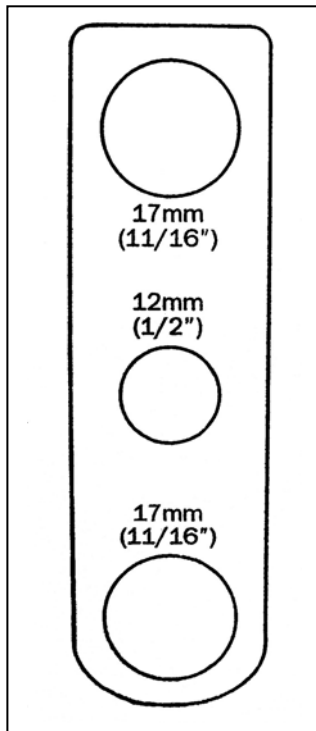

TEMPLATE CUT OUT

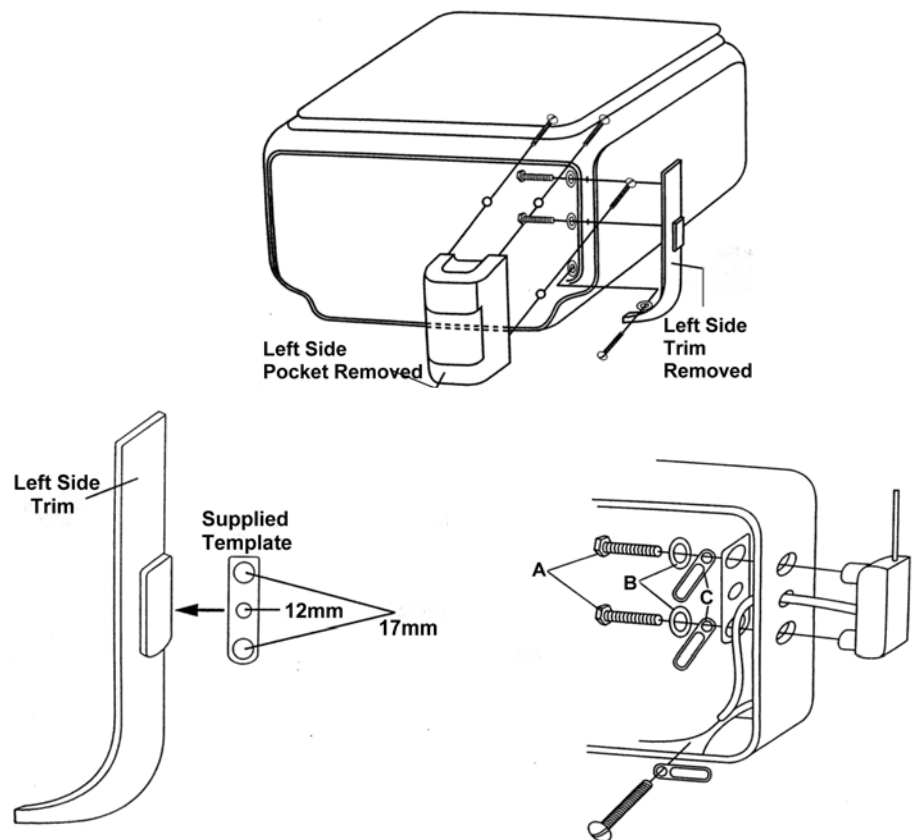

**Antenna Staff Alignment.**

Rotate the antenna so that when in the fold down position, it faces forward. Place the antenna in down position and tighten the locknut as shown below:

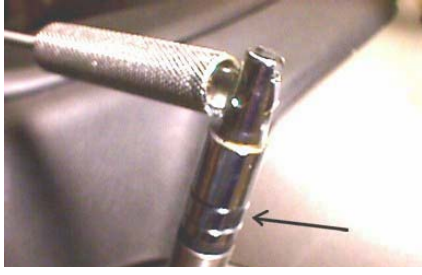

**DIAGRAM B**

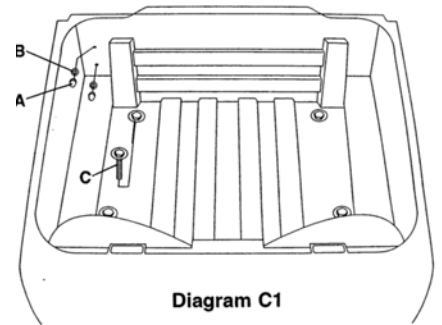
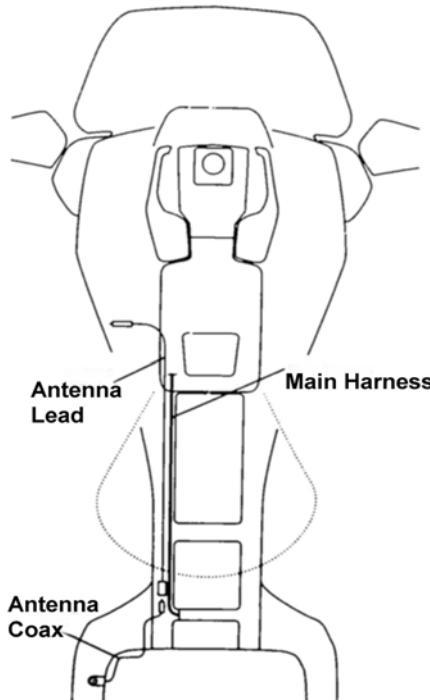

Diagram C1

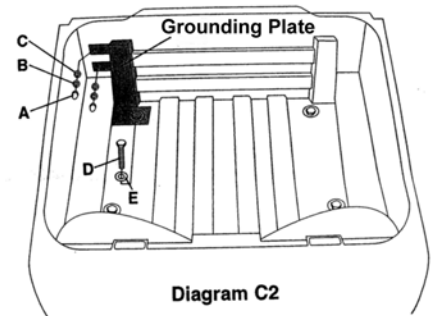

Diagram C2

**Antenna Assembly**

1. Remove black Allen head stud from antenna base with large Allen wrench provided. **Figure 1.** If desired, add a drop of **blue** loc tight to the top and bottom of the stud and reinstall.
2. Tighten the black Allen head stud using the large Allen wrench. **Figure 2.**
- 3 Turn the locknut until it contacts the antenna base.
4. Screw the lower antenna section onto the black stud. **Figure 3.**
5. Put antenna in down position. **Figure 4.** Once the antenna is in the position desired facing towards the front of the bike, tighten the jam nut up against the lower antenna staff.
6. Attach the top antenna staff. Tighten Allen studs with small Allen wrench provided. **Figure 5.**



Figure 1

Figure 2



Figure 3



Figure 4



Figure 5

