

# HANDLEBAR TANK (0,56 gal.)

COD. 5000002597 REV1

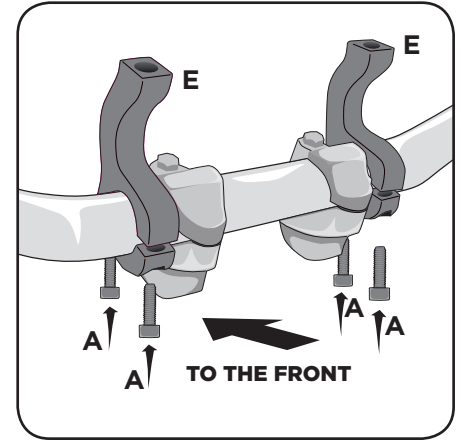
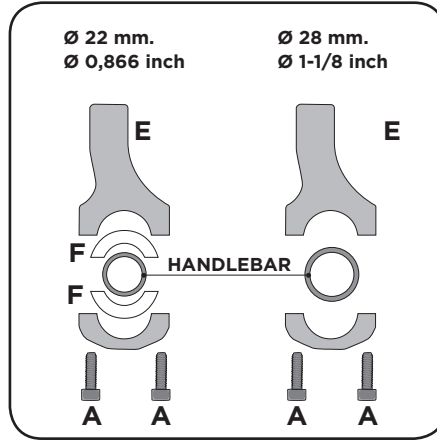
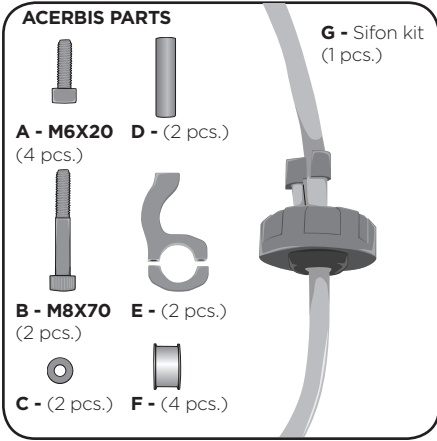

**1.** For handle-bars with a diameter 22 mm. use collars (F) - see design.

**2.** To fix the bracket on the handle-bar without closing the screws firmly.

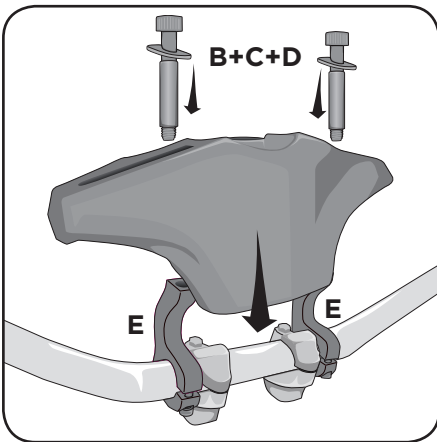

**3.** Position the additional tank over the handle-bar and brackets and secure with the bolts provided.

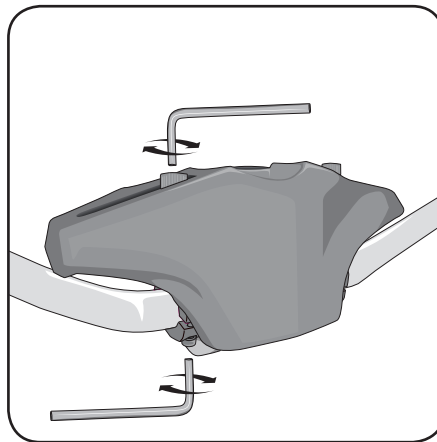

**4.** Check all the brackets are secure.

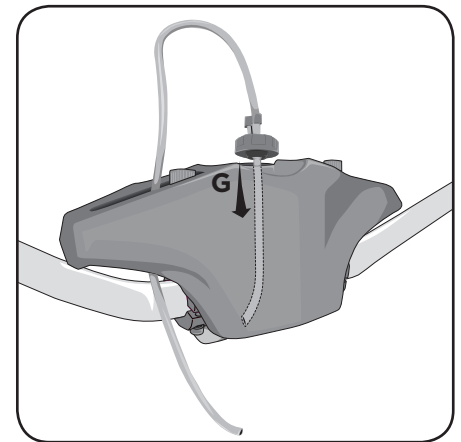

**5.** Fill up bike tank and also the handlebar tank, assemble the cap making sure the syphon tube goes to the bottom of the fuel tank.

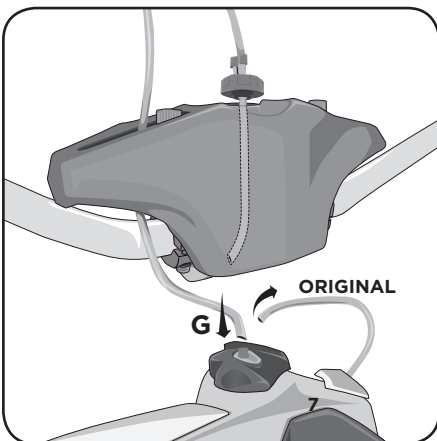

**6.** Remove the breather pipe from the main tank and replace this with the syphon kit provided (G). Your tank will now breath through your new handlebar tank and fuel will syphon as you ride into your main tank.

## FOR COMPETITION USE ONLY

DISCLAIMER: Due to uncontrolled variables in the manufacturing process of rotationally molded fuel tanks, the fuel tank may vary in size and shape by up 7% of the manufacturer's original listed capacity.

## WARNING!

Clean tank interior thoroughly before installation. install this fuel tank only in a well ventilated area, as gasoline fumes are extremely dangerous. do not start operate the vehicle if there are any fuel leaks! acerbis recommends that installation be done by licensed mechanic. read all instructions first before beginning installation.