

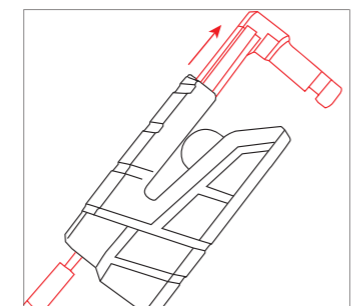

**ABUS 8077  
Granit Detecto**

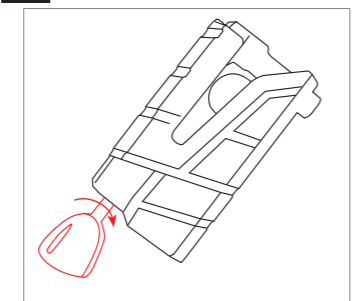

**1**

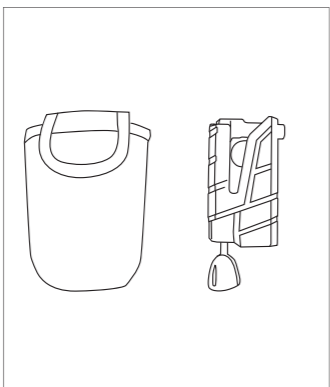

**2**



**3**

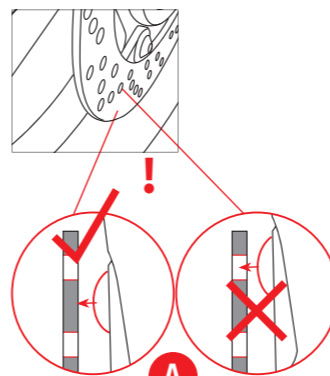
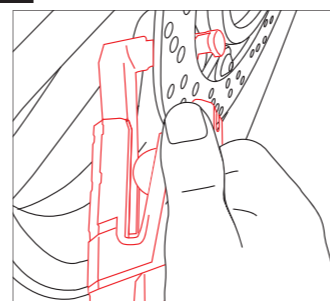

**4**

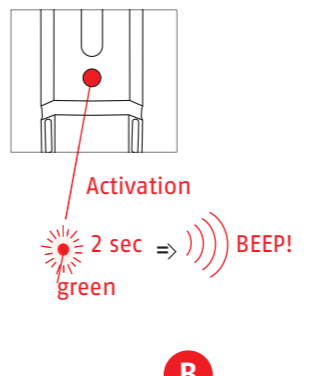
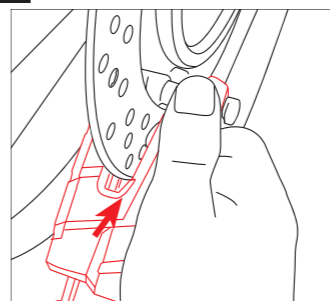

**5**

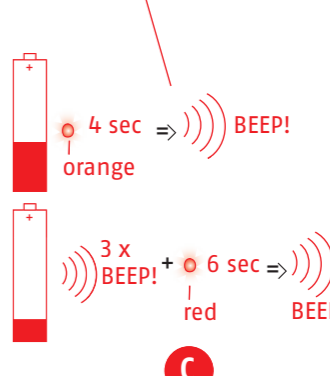
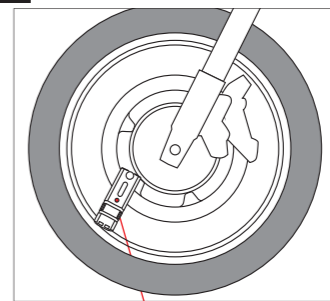

**6**

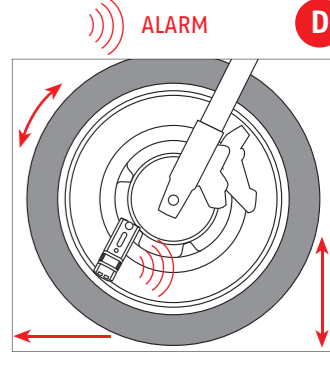
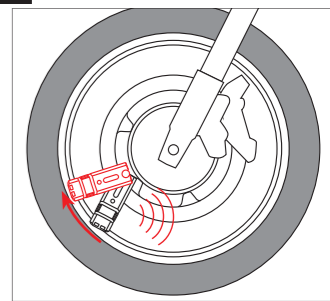

**7**

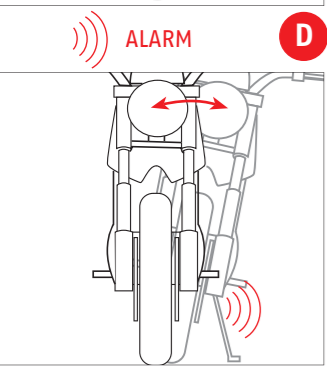
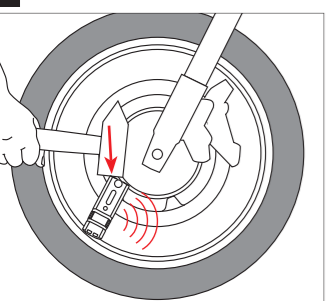

**8**

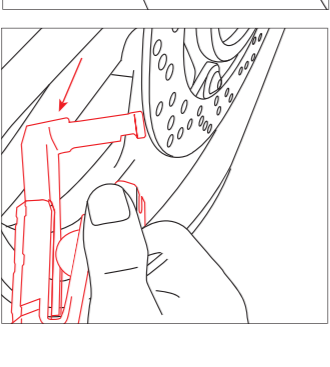
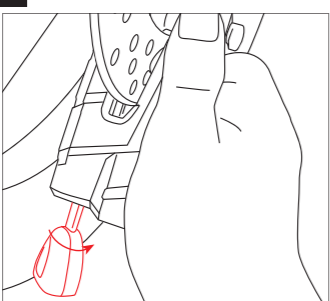

**9**

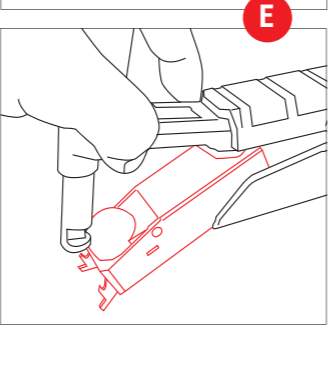
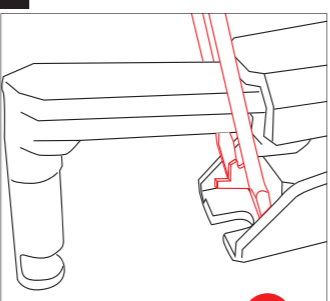

**10**

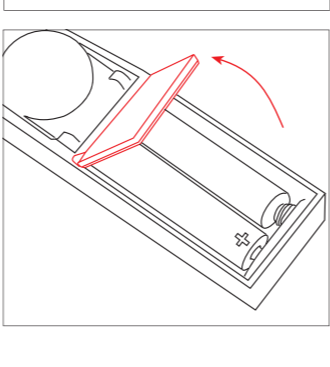
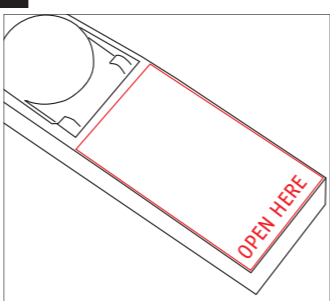

**11**

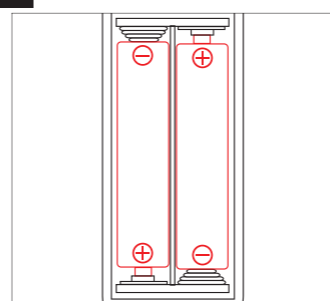

2 x AAA incl.

**12**

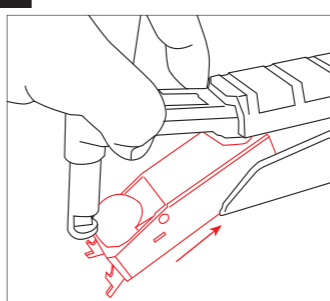

**13**

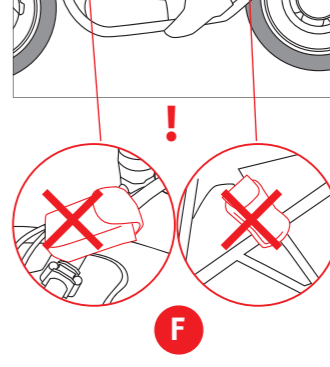
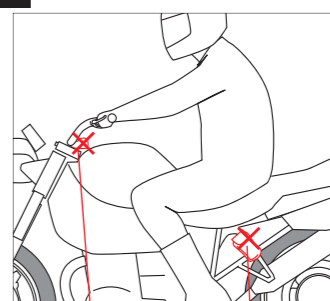

**14**

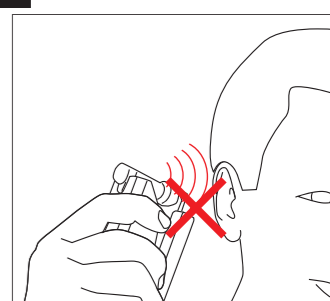

100 db !

- A** Open the lock, pull the bolt out and insert it through an opening of the brake disc. Close the lock by sliding the lock body back into position and lock it. The lock is then automatically activated. (see Fig. 3-5).
- B** Arming is indicated with an LED that shines for 2 seconds (green) and a subsequent beep. Repeated flashing every 6 seconds (red) signals activation. A warning beep tone sounds after unlocking, pull the key out quickly (5 seconds until the alarm goes off).
- C** Low battery warning: rapid flickering of the orange LED. Arming is indicated after 4 seconds by a beep. The alarm function is still fully functional, but batteries should be replaced soon. Very low battery warning: Rapid flickering of the red LED and 3 short "beep" tones. Arming is indicated after 6 seconds by a beep. The alarm function can not be guaranteed to full extend. Batteries should be replaced as soon as possible.
- D** The alarm goes off by any movement or shock of lock (3D-Position System; pic 6-7). The alarm stops automatically after approx. 15 seconds and the detection system reactivates again.
- E** To change the batteries, open the lock and slide the bolt out. Use two screwdrivers to release and remove the electronic unit. We recommend using high-quality alkaline batteries. Pay attention to correct polarity (+/-) when inserting.
- F** Safety instructions: Do not transport the lock externally on the motorcycle while riding (accident hazard).

Note: Do not short-circuit the batteries; do not throw them into fire and do not charge

Batteries may be returned after use.



ABUS is not liable to damages or inquiries caused by inappropriate mounting. Any legal rights remain unaffected. Subject to technical modifications.